

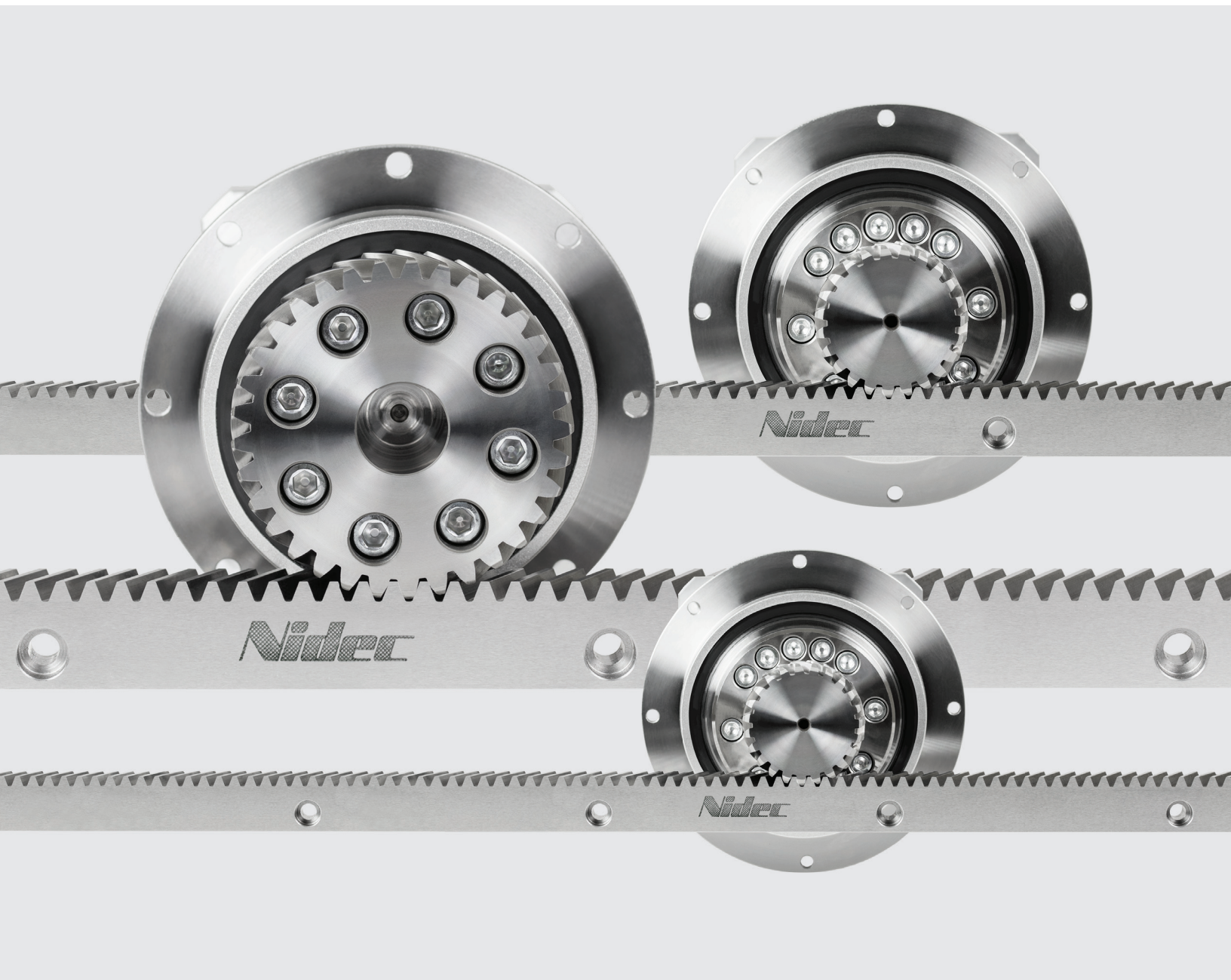

Rack and Pinion Systems & Components



Our Company

Our Company Nidec Drive Technology Corporation has established itself as the leading supplier of precision gearing solutions to the industrial automation marketplace. Since 1952, when we introduced the world's first mechanical variable speed drive, Nidec DTC has expanded into a diverse manufacturer of high precision power transmission systems for highly dynamic motion control applications. In 1994, Nidec DTC was acquired by the NIDEC Corporation and became formally known as Nidec Drive Technology. Nidec DTC began to focus on accelerating production volumes as the global market for motion control and mechatronics grew at an accelerated rate. We saw a unique opportunity to supply our customer base with the highest variety of transmission technologies, which brought forward strain wave, index table and worm gear products to complement our existing portfolio of planetary and cycloidal gearheads. The result for our customers was a single source drive solutions supplier.

Today, our company is shipping over 100,000 gearheads per month out of our manufacturing plants in Kyoto and Shanghai. Our products are used in robotics, machine tools, food packaging, printing, paper converting, material handling, medical, semiconductor and aerospace related systems. Our diverse product portfolio, state-of-the-art equipment, engineering knowhow and manufacturing scale allow our customers to compete and expand their businesses globally. Nidec DTC has over 2,400 employees strong with a presence across five continents. Our engineering staff, customer support team and distribution partners undergo rigorous product training to ensure the quickest response to our customers' needs. Our aim is to continue to innovate and provide the highest quality, best-in-class products and services for our customer base.

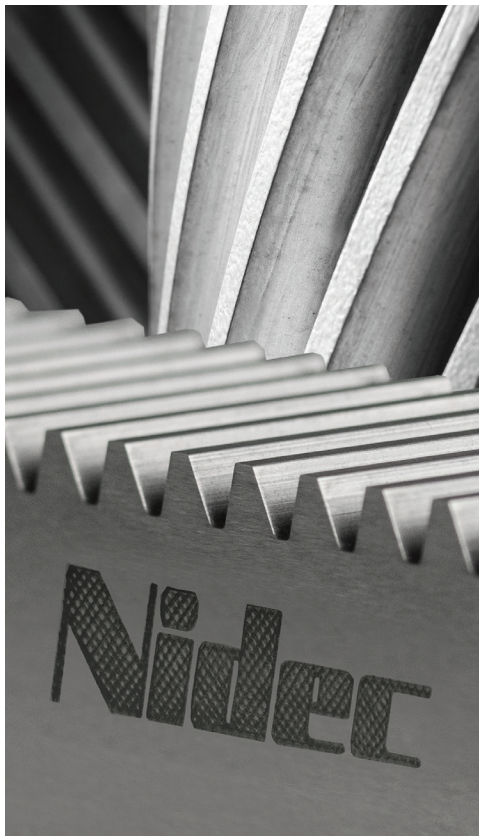

Total Drive Train Solutions

Nidec Drive Technology has made significant inroads into the machine tool and robotic handling markets globally. Our customers in these markets rely on us daily for our technical expertise in the area of power transmission and have pushed us to supply beyond the gearbox to help enhance the productivity of their machines.

Our ISO 9001/14001 state of the art manufacturing facility performs all critical processes in-house, including cutting, machining, milling, broaching, grinding induction hardening and testing. Pinions and gearboxes are factory assembled and tested as a system, saving our customers valuable time.

We offer a comprehensive lineup of rack and pinion drive systems with exceptional accuracy, system rigidity, feed forces, torque density and efficiency. Each component of the system—gearbox, rack and pinion—is optimized to meet these demands. Although we focus on highly dynamic applications, we also offer more cost-effective options for less challenging axes.

Helical and straight racks are both available, from module 1.5 to module 12, with quality levels from 5 to 10 and lengths up to 3000mm. Our core products are induction hardened and ground, but we can offer a variety of heat treatment and surface finish options. Pinions are offered for keyed shaft or ISO9409-1-A mounting interfaces.

Your drive partner for the long run

Systems

VRL System

- Standard performance system with feed forces up to 7,124N
- Lower requirements for positioning accuracy, rigidity and smoothness
- 23 ratios from 3:1 up to 100:1. Gearbox frame sizes 070-155mm
- Quality 6 rack in 1m lengths. ± 0.035 total pitch error. Induction hardened and ground
- Keyed, shrink fit connection between pinion and output shaft, secured axially with bolt and washer
- Fit for plasma and waterjet cutting machines, welding robots, 7th axis shuttles, gantry and material handling systems

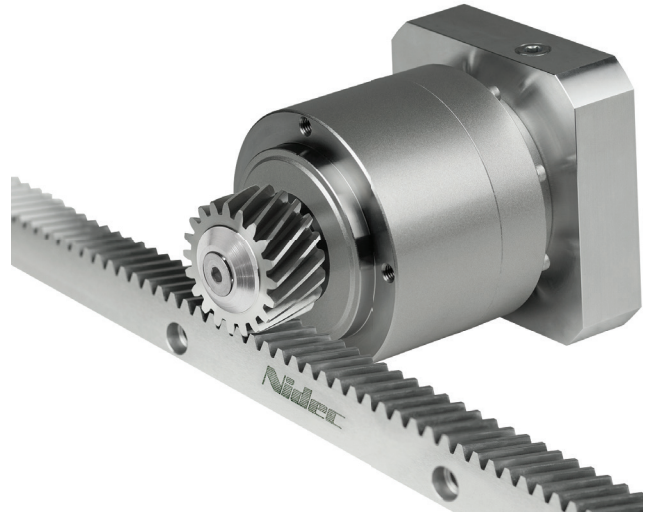

Gearbox	Module Size	Max Feed Force (N)	Max Feed Speed (m/sec)	Linear Backlash (μm)
VRL070	1.5	2030	5.0	0.03
VRL070	2	2230	5.0	0.04
VRL090	2	2531	5.0	0.04
VRL120	2	4788	5.0	0.04
VRL155	3	7124	5.0	0.06

VRS System

- High performance system with feed forces up to 12,710N
- High requirements for positioning accuracy, rigidity and smoothness
- Gearbox frame sizes 060-180mm. Tapered roller bearings for high radial and axial load capacity
- Quality 6 rack in 1m lengths. ± 0.035 total pitch error. Induction hardened and ground
- Keyed, shrink fit connection between pinion and output shaft, secured axially with bolt and washer
- Fit for applications with higher dynamics such as plastic or wood machining centers, CNC routers and pipe bending machines

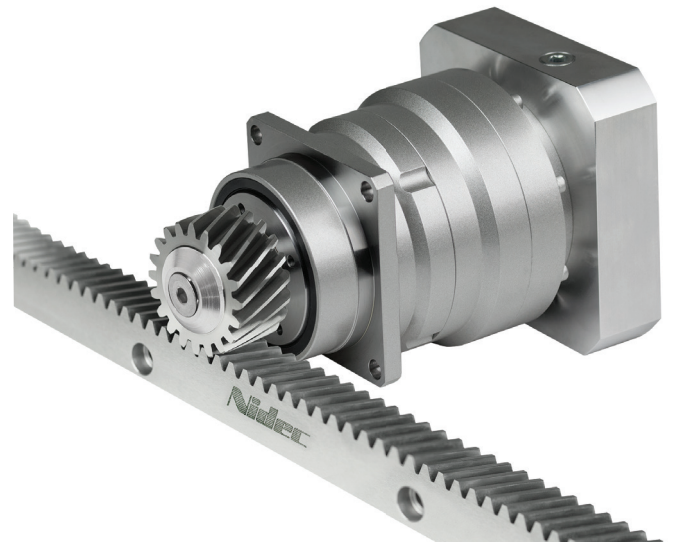

Gearbox	Module Size	Max Feed Force (N)	Max Feed Speed (m/sec)	Linear Backlash (μm)
VRS060	2	2515	5.0	0.04
VRS075	2	3133	5.0	0.04
VRS100	2	4797	5.0	0.04
VRS140	3	8291	6.0	0.06
VRS180	4	12710	6.0	0.08

VRT System

- High performance system with feed forces up to 19,540N
- Max requirements for positioning accuracy, rigidity and smoothness
- Gearbox frame sizes 064-200mm. Oversized tapered roller bearings for extreme radial and axial forces
- Quality 6 rack in 1m lengths. ± 0.035 total pitch error. Induction hardened and ground
- Compact ISO 9409 Flange connection with optimal tooth geometry
- Fit for high end machine tool applications such as portal milling machines, turning machines and measurement systems

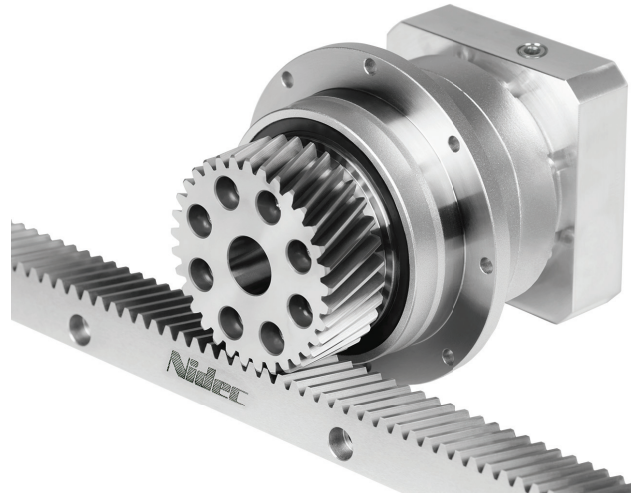

Gearbox	Module Size	Max Feed Force (N)	Max Feed Speed (m/sec)	Linear Backlash (μm)
VRT064	2	1713	5.0	0.04
VRT090	2	2352	6.5	0.04
VRT110	2	3692	6.5	0.04
VRT140	3	11016	6.8	0.06
VRT200	4	19540	7.5	0.08

VRT Torque+ System

- Max performance system with feed forces up to 29,463N
- Max requirements for linear stiffness, rigidity and torque density
- Gearbox frame sizes 090-200mm. Oversized tapered roller bearings for extreme radial and axial forces
- Quality 6 rack in 1m lengths. ± 0.035 total pitch error. Induction hardened and ground
- Compact ISO 9409 Flange connection with small pinion. Allows reduction in gearbox frame size and ratio
- Fit for high end machine tool applications such as portal milling machines, turning machines and measurement systems

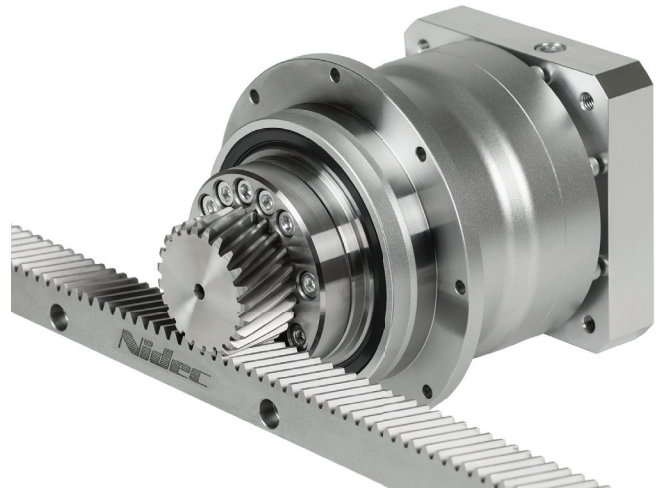

Gearbox	Module Size	Max Feed Force (N)	Max Feed Speed (m/sec)	Linear Backlash (μm)
VRT090	2	1799	3.0	0.04
VRT110	2	3648	3.5	0.04
VRT110	3	10177	3.0	0.06
VRT140	2	4002	3.0	0.04
VRT140	3	10696	3.5	0.06
VRT140	4	13465	3.0	0.08
VRT200	3	17920	5.0	0.06
VRT200	4	20879	4.5	0.08
VRT200	5	20866	5.0	0.10
VRT200	6	29463	5.0	0.12

Components

Racks

- Helical or straight cut profiles
- Modules 1.5 / 2 / 3 / 4 / 5 / 6 / 8 / 10 / 12
- Quality levels 5 through 10
- One-piece lengths of 0.5m, 1m, 2m and 3m available
- Materials: SAE 1141, C45E, 42CrMo4, 16MnCr5
- Heat treatments: Case hardening, carburizing with induction hardening and induction hardening. HRC 55-60
- Ground (all surfaces) or milled surface finishes
- Total pitch error as low as ± 0.028
- Readily available: Mod 2/3/4, SAE 1141, Q6, 1m length, ground

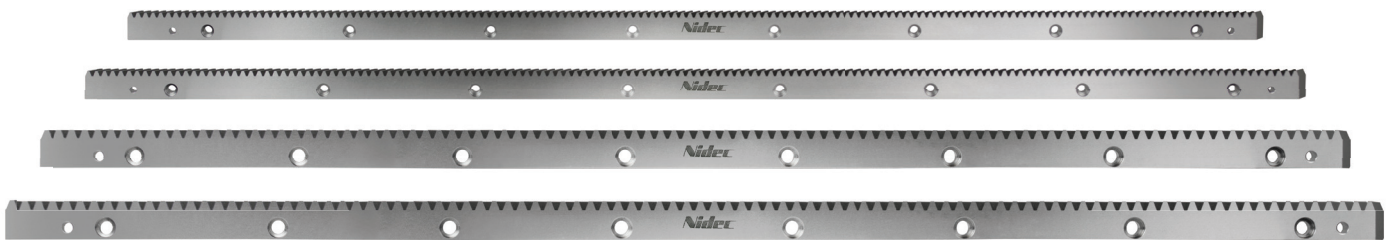

Pinions



Keyed Helical Pinion

- Keyed helical pinion with optimized tooth geometry
- Mod Sizes 1.5 / 2 / 3 / 4
- Quality level 6
- 20MnCr5 steel composition, case hardened and ground with 60 HRC
- Shrink fit connection ensures reliable positioning of the pinion
- Factory assembled



ISO9409-1-A Helical Large Pinion

- High precision ISO9409-1-A helical pinion for heavy loads and ultra-high accuracy
- Mod Sizes 2 / 3 / 4 / 5 / 6
- Quality level 5
- 20MnCr5 steel composition, case hardened and ground with 60 HRC
- Compact connection to VRT or EVT gearheads
- High move speeds with low lower input speed using large pitch diameter
- Factory assembled



ISO9409-1-A Helical Small Pinion

- High precision ISO9409-1-A small helical pinion for heavy loads and ultra-high accuracy and exceptional linear stiffness
- Mod Sizes 2 / 3 / 4 / 5 / 6
- Quality level 5
- 20MnCr5 steel composition, case hardened and ground with 60 HRC
- Compact connection to VRT or EVT gearheads
- Small pitch diameter allows reduction of the gearbox frame size and ratio
- Factory assembled

www.nidec-dtc.com



NIDEC DRIVE TECHNOLOGY CORPORATION

175 Wall Street, Glendale Heights, IL 60139 USA

Phone: (800) 842-1479 • info@nidec-dtc.com

© NIDEC DRIVE TECHNOLOGY AMERICA CORPORATION. Rack and Pinion Guide 02/2023.