

PRF SERIES

PRF is part of the latest generation economy product family from Nidec Drive Technology Corporation. The PRF redefines the economy planetary gear reducer segment by featuring helical cut gearing and a robust internal structure. Our customers benefit from a cost-effective, flexible, reliable design that can be adapted into a wide range of servo and stepper motor axes.

The PRF features a B5 style square output flange for convenient mounting to machinery or linear actuators and can be easily adapted to any motor. Frame sizes from 062-160, along with $\leq 8-10$ arc-minute backlash, allow the PRF to cover a broad range of application requirements where cost is a key consideration. As with all Nidec DTC planetary products, PRF is designed for maximum heat reduction and running efficiency through the use of special lubricants and seals.

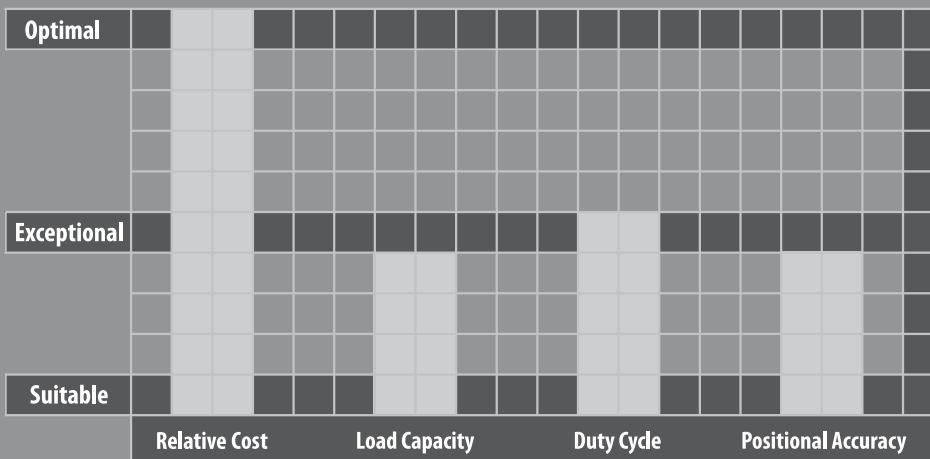

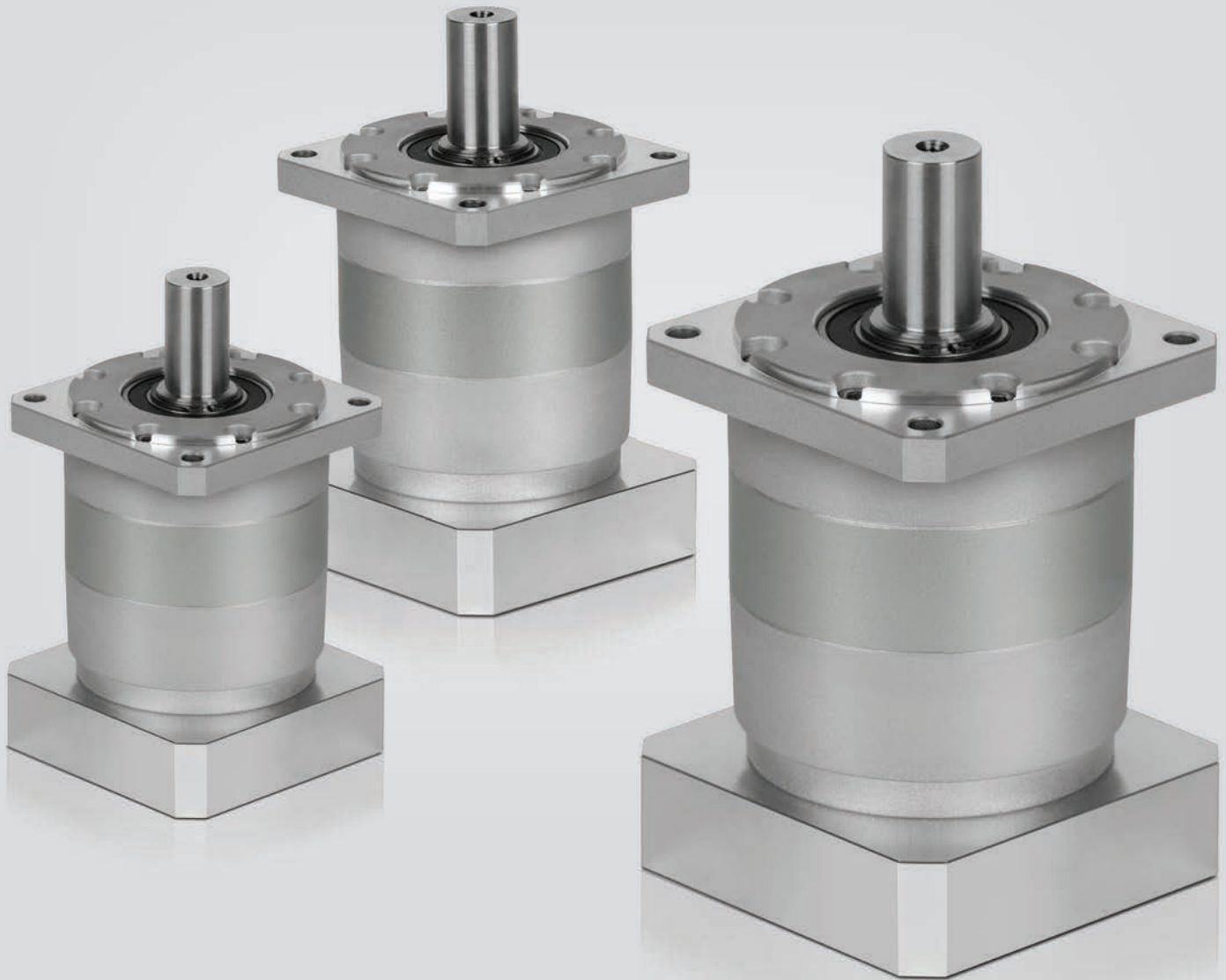

PRF SERIES

- Value engineered solution for low to mid-range motion control applications
- Low backlash, $\leq 8-10$ arc-min
- Four frame sizes, from 062 to 160
- Broad range of mounting adapters offer a simple, precise attachment to any motor
- Maintenance-free solution that is lubricated for life. High performance grease allows flexible mounting in any orientation
- B5 style square output flange for convenient mounting to machinery or linear actuators

PLANETARY *Inline Gear Reducers*

PRF Series Features

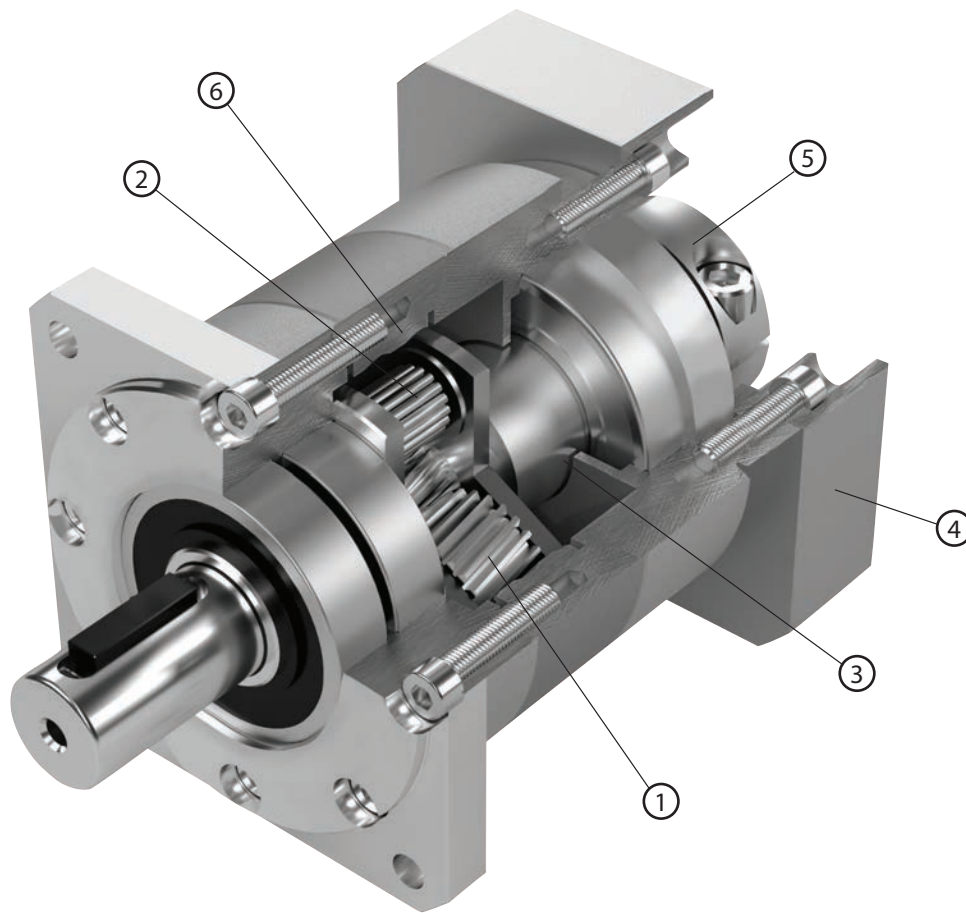

- ① Carburized helical gears for higher accuracy and smooth, quiet operation
- ② Uncaged needle roller bearings provide excellent torque density and torsional rigidity
- ③ Unique labyrinth input design greatly reduces heat and increases system efficiency.
- ④ Optimized mounting system with active centering on motor pilot diameter guarantees alignment of motor. Motor can be installed in any orientation
- ⑤ True concentric motor shaft clamping connection, optimized for your specific motor. Reduced inertia for dynamic performance and balanced for high speed operation
- ⑥ Ring gear machined directly into the housing, not welded or pressed in. Provides greater concentricity and elimination of speed fluctuation

PRF Series Model Code

PRF	082	10	K	8	19HB16
Series Name	Frame Size	Ratio	Output Mounting Style	Backlash	Motor Mounting Code
PRF	062 082 120 160	1 Stage: 3 4 5 8 9 10 2 Stage: 12 15 16 20 25 32 40 50 80 100	K: Keyed Shaft	1 Stage: ≤8 arc-min 2 Stage: ≤10 arc-min	Motor mounting code varies depending on the motor

* Use the selection tool link below to configure the code

VRT
VRS
VRB
VRL
PRF
PRE
VRSF

PRF 062 1-Stage Specifications

Frame Size	062							
Ratio	Unit	Note	3	4	5	8	9	10
Nominal Output Torque	[Nm]	*1	35	50	50	50	35	35
Maximum Output Torque	[Nm]	*2	55	79	79	76	55	55
Emergency Stop Torque	[Nm]	*3	80	90	90	90	80	80
Nominal Input Speed	[rpm]	*4	3000					
Maximum Input Speed	[rpm]	*5	6000					
No Load Running Torque	[Nm]	*6	0.15					
Maximum Radial Load	[N]	*7	550					
Maximum Axial Load	[N]	*8	680					
Moment of Inertia ($\leq \varnothing 8$)	[kgcm ²]	--	-	-	-	-	-	-
Moment of Inertia ($\leq \varnothing 14$)	[kgcm ²]	--	0.19	0.16	0.15	0.14	0.14	0.14
Moment of Inertia ($\leq \varnothing 19$)	[kgcm ²]	--	0.40	0.37	0.36	0.35	0.35	0.35
Efficiency	[%]	*9	95					
Torsional Rigidity	[Nm/arcmin]	*10	2.3					
Maximum Torsional Backlash	[Arc-min]	--	≤ 8					
Noise Level	dB [A]	*11	≤ 58					
Protection Class	--	--	IP54					
Ambient Temperature	[°C]	--	0-40					
Permitted Housing Temperature	[°C]	--	90					
Weight	[kg]	*12	1.0					

*1 Continuous rating at 100% duty cycle, S1 operation, measured at 100rpm output and 30°C

*2 Permitted for 30,000 output shaft revolutions. Note operation factor on page 469

*3 The maximum torque allowed under a stress situation. Permitted 1,000 times during service life

*4 The average input speed at nominal torque. Maintain housing temperature below permitted value

*5 The maximum intermittent input speed

*6 Torque at no load applied to the input shaft at nominal input speed

*7 The maximum radial load that the gearbox can accept

*8 The maximum axial load that the gearbox can accept

*9 The efficiency at the nominal output torque ratings

*10 This does not include lost motion

*11 Contact Nidec Drive Technology for the testing conditions and environment

*12 Weight may vary slightly between models

PRF 062 2-Stage Specifications

Frame Size	062											
Ratio	Unit	Note	12	15	16	20	25	32	40	50	80	100
Nominal Output Torque	[Nm]	*1	35	35	50	50	50	50	50	46	46	35
Maximum Output Torque	[Nm]	*2	46	46	66	66	66	66	66	66	66	46
Emergency Stop Torque	[Nm]	*3	80	80	90	90	90	90	90	90	90	80
Nominal Input Speed	[rpm]	*4	3000									
Maximum Input Speed	[rpm]	*5	6000									
No Load Running Torque	[Nm]	*6	0.04									
Maximum Radial Load	[N]	*7	550									
Maximum Axial Load	[N]	*8	680									
Moment of Inertia ($\leq \varnothing 8$)	[kgcm ²]	--	0.08	0.07	0.07	0.06	0.06	0.07	0.06	0.06	0.06	0.06
Moment of Inertia ($\leq \varnothing 14$)	[kgcm ²]	--	0.16	0.14	0.14	0.14	0.14	0.14	0.13	0.14	0.14	0.14
Moment of Inertia ($\leq \varnothing 19$)	[kgcm ²]	--	-	-	-	-	-	-	-	-	-	-
Efficiency	[%]	*9	90									
Torsional Rigidity	[Nm/arcmin]	*10	2.3									
Maximum Torsional Backlash	[Arc-min]	--	≤ 10									
Noise Level	dB [A]	*11	≤ 58									
Protection Class	--	--	IP54									
Ambient Temperature	[°C]	--	0-40									
Permitted Housing Temperature	[°C]	--	90									
Weight	[kg]	*12	1.5									

*1 Continuous rating at 100% duty cycle, S1 operation, measured at 100rpm output and 30°C

*2 Permitted for 30,000 output shaft revolutions. Note operation factor on page 469

*3 The maximum torque allowed under a stress situation. Permitted 1,000 times during service life

*4 The average input speed at nominal torque. Maintain housing temperature below permitted value

*5 The maximum intermittent input speed

*6 Torque at no load applied to the input shaft at nominal input speed

*7 The maximum radial load that the gearbox can accept

*8 The maximum axial load that the gearbox can accept

*9 The efficiency at the nominal output torque ratings

*10 This does not include lost motion

*11 Contact Nidec Drive Technology for the testing conditions and environment

*12 Weight may vary slightly between models

VRSF

PRE

PRF

VRL

VRB

VRS

VRT

PLANETARY Inline Gear Reducers

PRF 062 1-Stage Dimensions

Input bore size $\leq \phi 14$ mm

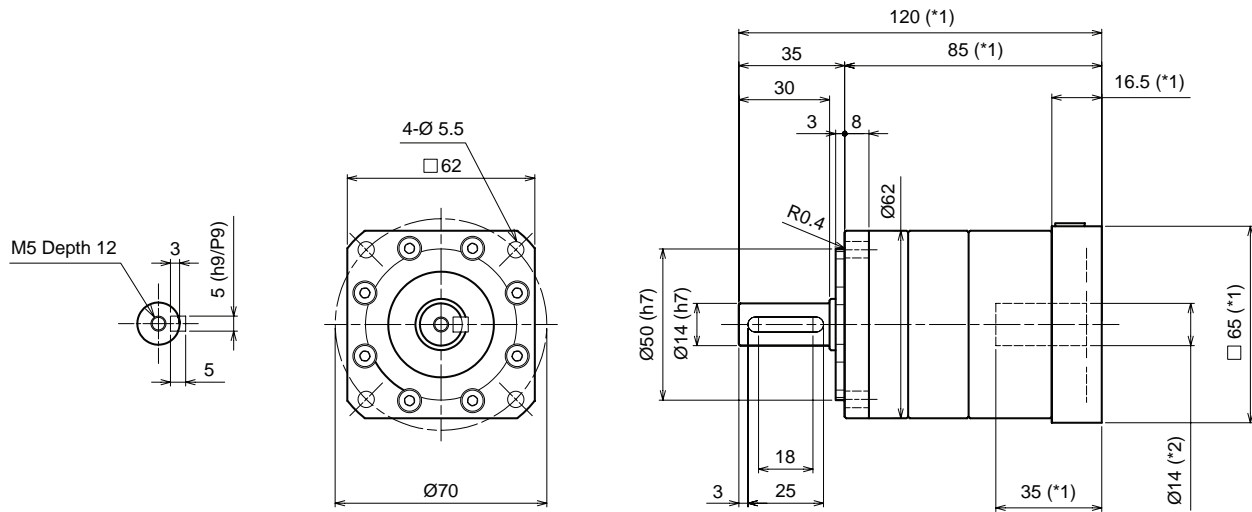

Input bore size $\leq \phi 19$ mm

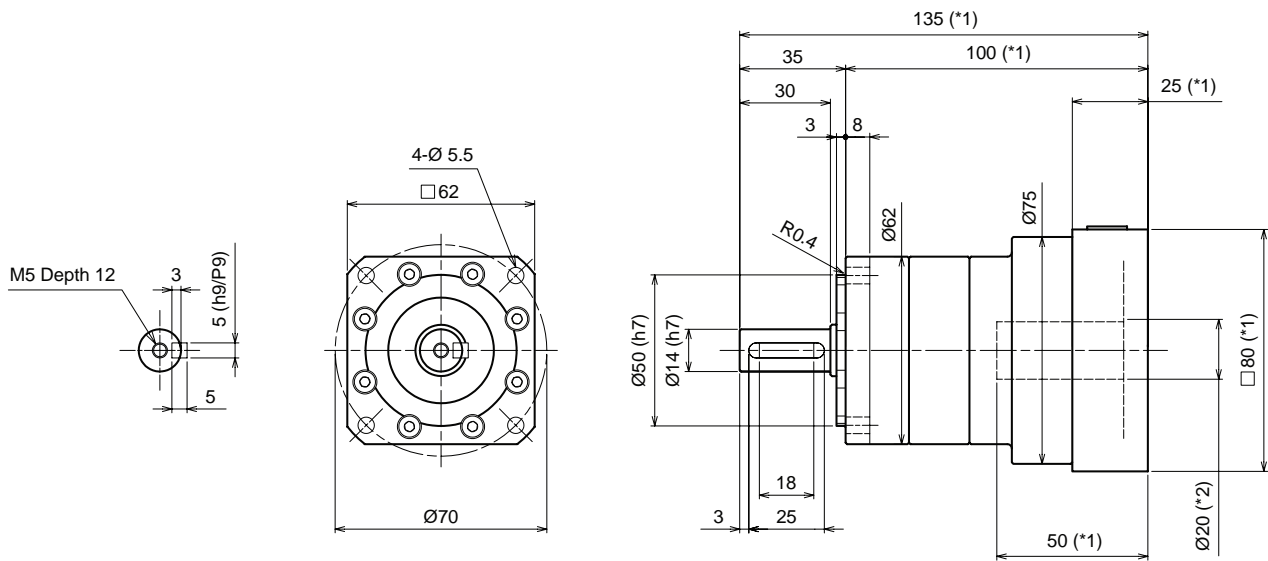

*1 Length will vary depending on motor

*2 Bushing will be inserted to adapt to motor shaft

PRF 062 2-Stage Dimensions

Input bore size $\leq \varnothing 8$ mm

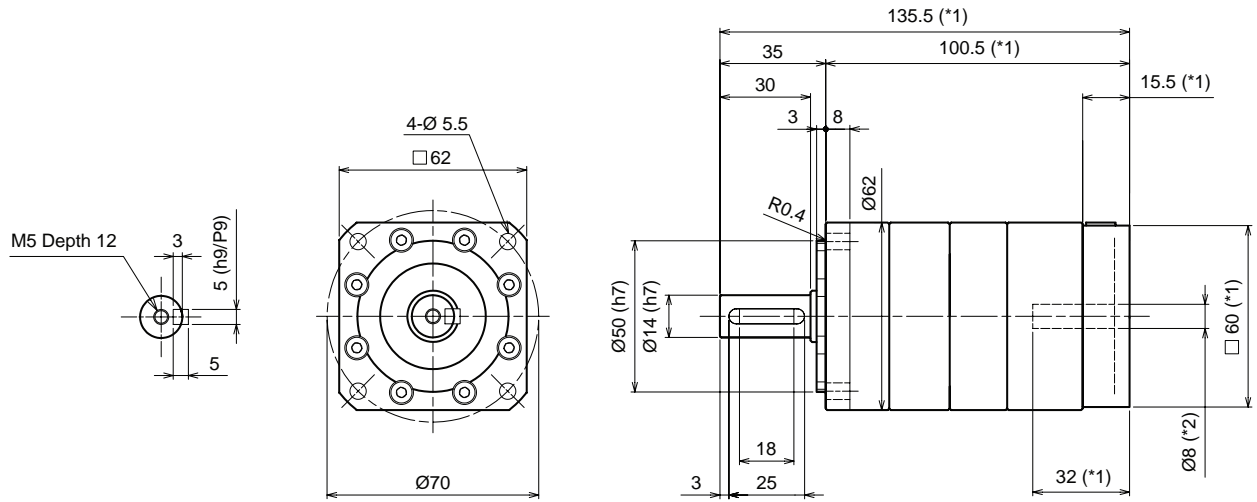

Input bore size $\leq \varnothing 14$ mm

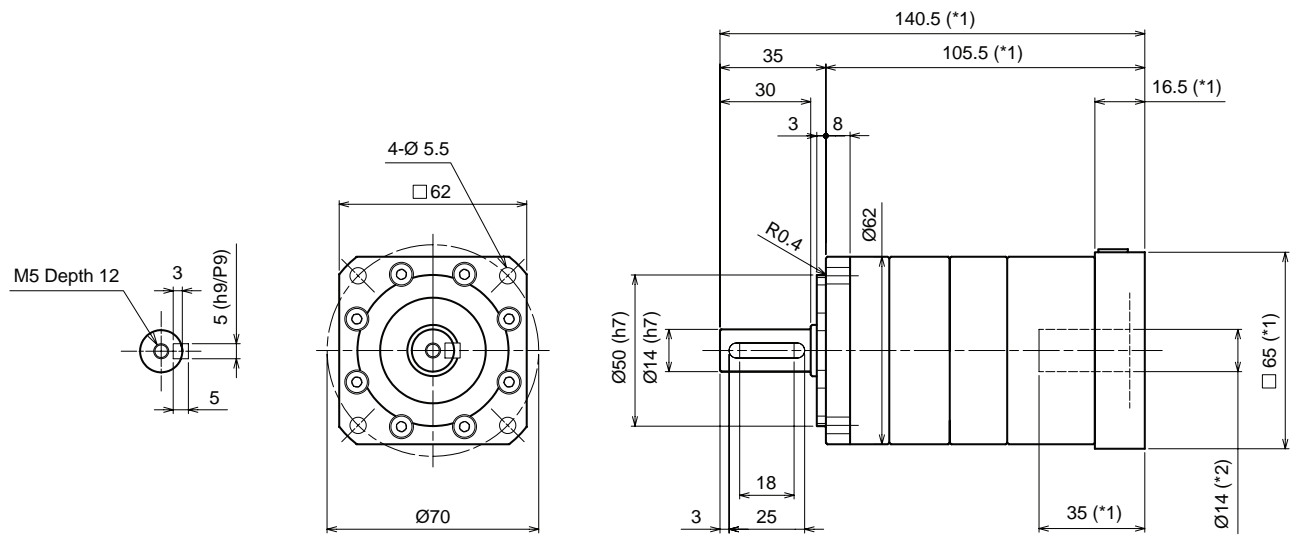

*1 Length will vary depending on motor

*2 Bushing will be inserted to adapt to motor shaft

VRSF

PRE

PRF

VRL

VRB

VRS

VRT

PRF 082 1-Stage Specifications

Frame Size	082							
Ratio	Unit	Note	3	4	5	8	9	10
Nominal Output Torque	[Nm]	*1	80	125	125	125	80	80
Maximum Output Torque	[Nm]	*2	135	200	200	190	145	145
Emergency Stop Torque	[Nm]	*3	200	210	210	210	200	200
Nominal Input Speed	[rpm]	*4	3000					
Maximum Input Speed	[rpm]	*5	6000					
No Load Running Torque	[Nm]	*6	0.35					
Maximum Radial Load	[N]	*7	990					
Maximum Axial Load	[N]	*8	1500					
Moment of Inertia ($\leq \varnothing 14$)	[kgcm ²]	--	0.57	0.41	0.35	0.31	0.30	0.30
Moment of Inertia ($\leq \varnothing 19$)	[kgcm ²]	--	1.04	0.87	0.82	0.77	0.77	0.76
Moment of Inertia ($\leq \varnothing 28$)	[kgcm ²]	--	3.13	2.96	2.91	2.86	2.86	2.85
Efficiency	[%]	*9	95					
Torsional Rigidity	[Nm/arc-min]	*10	6					
Maximum Torsional Backlash	[arc-min]	--	≤ 8					
Noise Level	dB [A]	*11	≤ 60					
Protection Class	--	--	IP54					
Ambient Temperature	[°C]	--	0-40					
Permitted Housing Temperature	[°C]	--	90					
Weight	[kg]	*12	2.5					

*1 Continuous rating at 100% duty cycle, S1 operation, measured at 100rpm output and 30°C

*2 Permitted for 30,000 output shaft revolutions. Note operation factor on page 469

*3 The maximum torque allowed under a stress situation. Permitted 1,000 times during service life

*4 The average input speed at nominal torque. Maintain housing temperature below permitted value

*5 The maximum intermittent input speed

*6 Torque at no load applied to the input shaft at nominal input speed

*7 The maximum radial load that the gearbox can accept

*8 The maximum axial load that the gearbox can accept

*9 The efficiency at the nominal output torque ratings

*10 This does not include lost motion

*11 Contact Nidec Drive Technology for the testing conditions and environment

*12 Weight may vary slightly between models

PRF 082 2-Stage Specifications

Frame Size	082												
	Ratio	Unit	Note	12	15	16	20	25	32	40	50	80	100
Nominal Output Torque	[Nm]	*1	80	80	125	125	125	125	125	125	120	120	80
Maximum Output Torque	[Nm]	*2	108	108	165	165	165	165	165	165	165	165	112
Emergency Stop Torque	[Nm]	*3	200	200	210	210	210	210	210	210	210	210	200
Nominal Input Speed	[rpm]	*4	3000										
Maximum Input Speed	[rpm]	*5	6000										
No Load Running Torque	[Nm]	*6	0.06										
Maximum Radial Load	[N]	*7	990										
Maximum Axial Load	[N]	*8	1500										
Moment of Inertia ($\leq \varnothing 14$)	[kgcm ²]	--	0.39	0.33	0.33	0.32	0.32	0.32	0.28	0.29	0.28	0.28	0.28
Moment of Inertia ($\leq \varnothing 19$)	[kgcm ²]	--	0.84	0.78	0.78	0.77	0.77	0.78	0.73	0.74	0.74	0.74	0.74
Moment of Inertia ($\leq \varnothing 28$)	[kgcm ²]	--	2.91	2.85	2.85	2.84	2.83	2.84	2.79	2.81	2.81	2.81	2.81
Efficiency	[%]	*9	90										
Torsional Rigidity	[Nm/arc-min]	*10	6										
Maximum Torsional Backlash	[arc-min]	--	≤ 10										
Noise Level	dB [A]	*11	≤ 60										
Protection Class	--	--	IP54										
Ambient Temperature	[°C]	--	0-40										
Permitted Housing Temperature	[°C]	--	90										
Weight	[kg]	*12	3.0										

- *1 Continuous rating at 100% duty cycle, S1 operation, measured at 100rpm output and 30°C
- *2 Permitted for 30,000 output shaft revolutions. Note operation factor on page 469
- *3 The maximum torque allowed under a stress situation. Permitted 1,000 times during service life
- *4 The average input speed at nominal torque. Maintain housing temperature below permitted value
- *5 The maximum intermittent input speed
- *6 Torque at no load applied to the input shaft at nominal input speed
- *7 The maximum radial load that the gearbox can accept
- *8 The maximum axial load that the gearbox can accept
- *9 The efficiency at the nominal output torque ratings
- *10 This does not include lost motion
- *11 Contact Nidec Drive Technology for the testing conditions and environment
- *12 Weight may vary slightly between models

VRSF

PRE

PRF

VRL

VRB

VRS

VRT

PLANETARY Inline Gear Reducers

PRF 082 1-Stage Dimensions

Input bore size $\leq \varnothing 14 \text{ mm}$

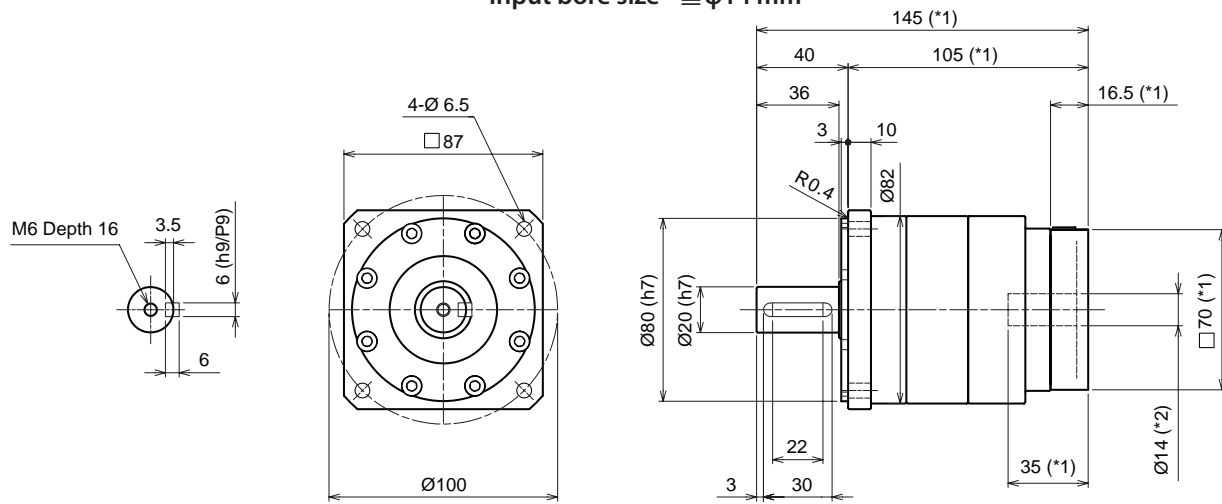

Input bore size $\leq \varnothing 19 \text{ mm}$

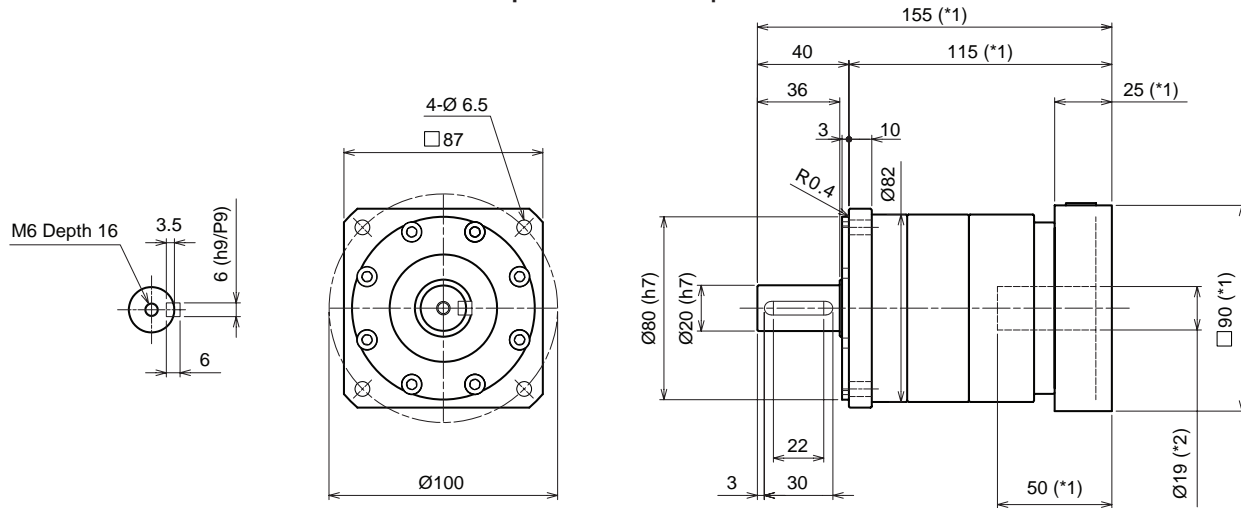

Input bore size $\leq \varnothing 28 \text{ mm}$

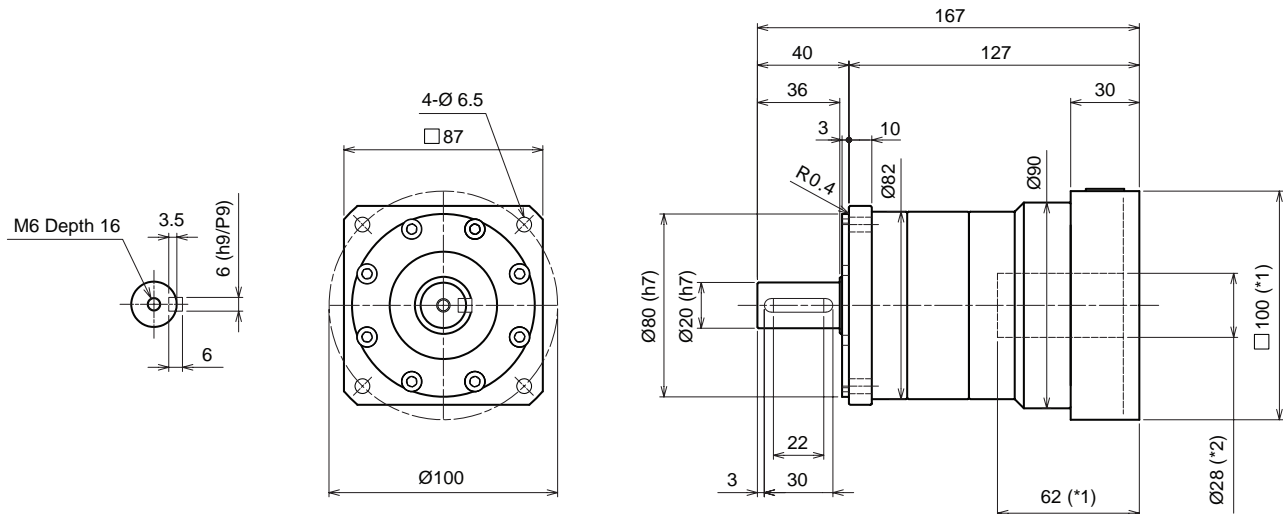

*1 Length will vary depending on motor

*2 Bushing will be inserted to adapt to motor shaft

PRF 082 2-Stage Dimensions

Input bore size $\leq \varnothing 14$ mm

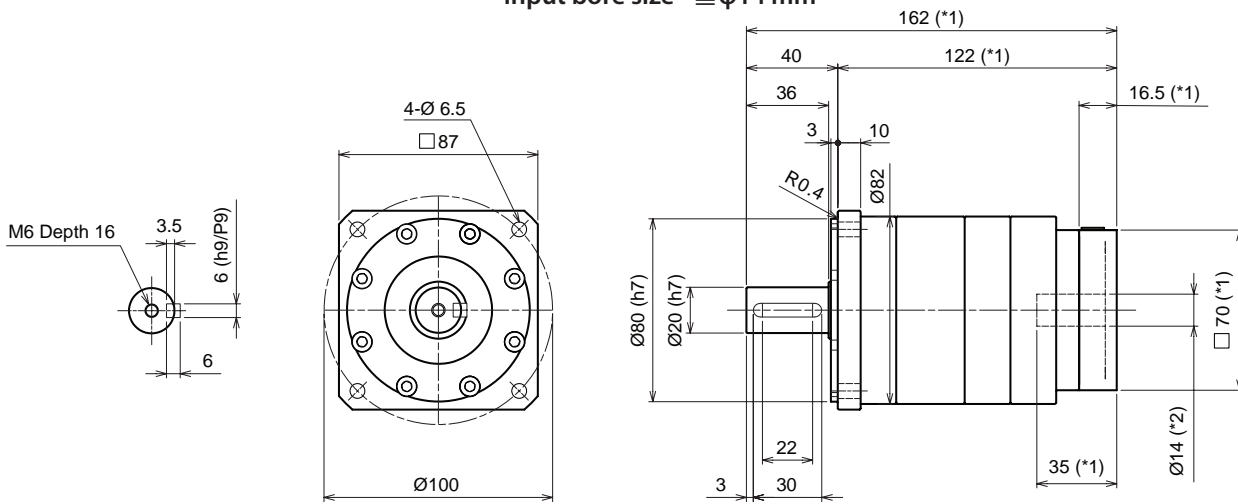

Input bore size $\leq \varnothing 19$ mm

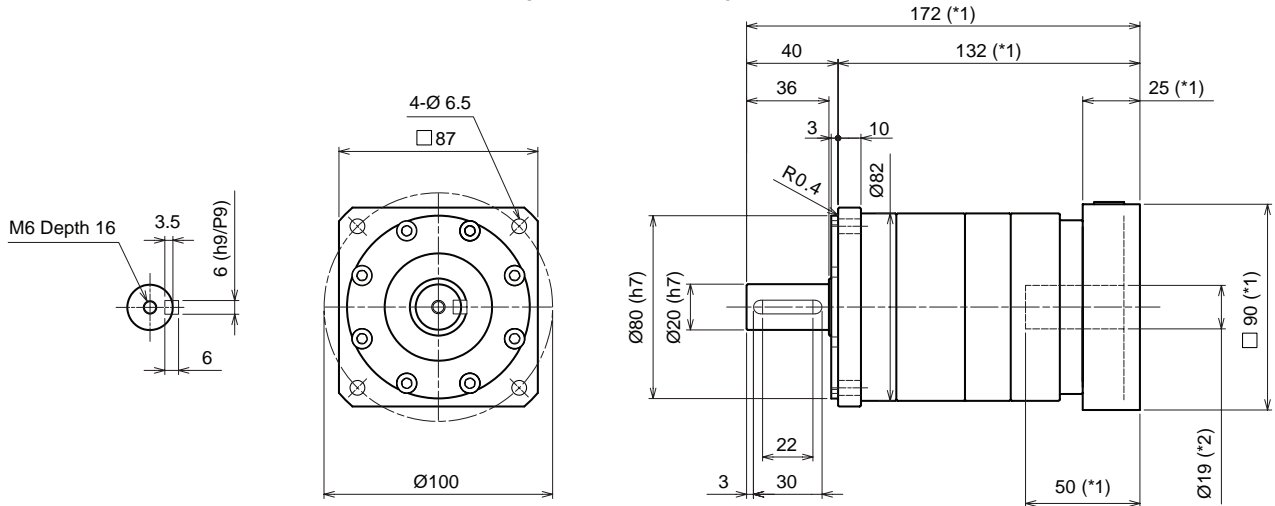

Input bore size $\leq \varnothing 28$ mm

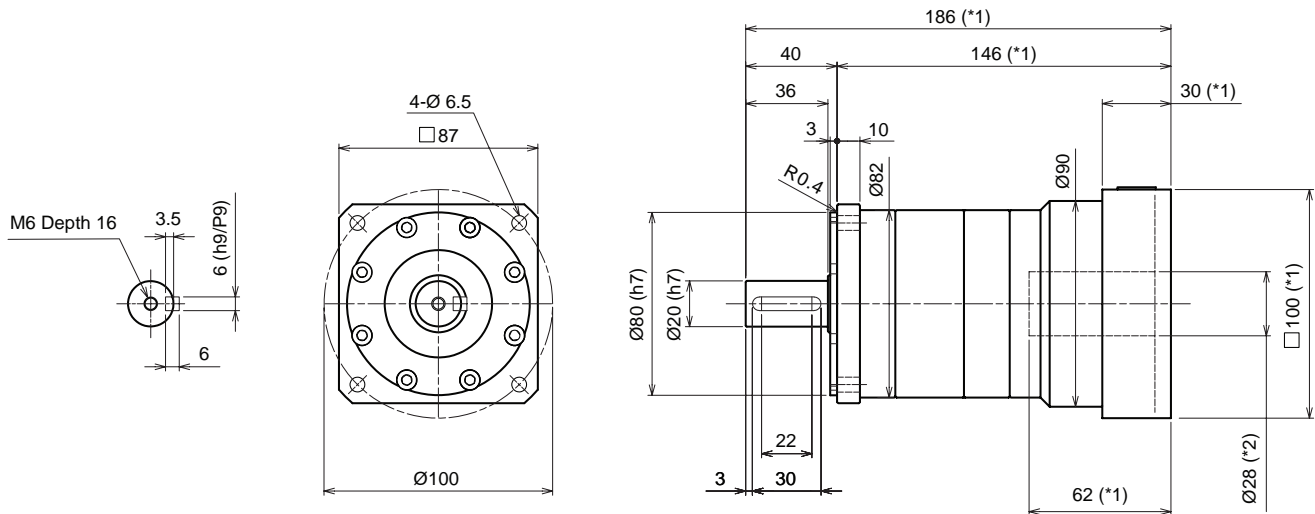

*1 Length will vary depending on motor

*2 Bushing will be inserted to adapt to motor shaft

VRSF

PRE

PRF

VRL

VRB

VRB

VRT

PRF 120 1-Stage Specifications

Frame Size	120							
Ratio	Unit	Note	3	4	5	8	9	10
Nominal Output Torque	[Nm]	*1	225	330	330	330	225	225
Maximum Output Torque	[Nm]	*2	340	490	490	480	370	370
Emergency Stop Torque	[Nm]	*3	500	550	550	550	500	500
Nominal Input Speed	[rpm]	*4	3000					
Maximum Input Speed	[rpm]	*5	6000					
No Load Running Torque	[Nm]	*6	1.30					
Maximum Radial Load	[N]	*7	2000					
Maximum Axial Load	[N]	*8	2800					
Moment of Inertia ($\leq \varnothing 19$)	[kgcm ²]	--	2.38	1.45	1.17	0.88	0.85	0.83
Moment of Inertia ($\leq \varnothing 28$)	[kgcm ²]	--	4.41	3.48	3.13	2.89	2.86	2.84
Moment of Inertia ($\leq \varnothing 38$)	[kgcm ²]	--	12.27	11.34	11.05	10.72	10.69	10.67
Efficiency	[%]	*9	95					
Torsional Rigidity	[Nm/arc-min]	*10	15					
Maximum Torsional Backlash	[arc-min]	--	≤ 8					
Noise Level	dB [A]	*11	≤ 65					
Protection Class	*15	--	IP54					
Ambient Temperature	[°C]	--	0-40					
Permitted Housing Temperature	[°C]	--	90					
Weight	[kg]	*12	6.8					

*1 Continuous rating at 100% duty cycle, S1 operation, measured at 100rpm output and 30°C

*2 Permitted for 30,000 output shaft revolutions. Note operation factor on page 469

*3 The maximum torque allowed under a stress situation. Permitted 1,000 times during service life

*4 The average input speed at nominal torque. Maintain housing temperature below permitted value

*5 The maximum intermittent input speed

*6 Torque at no load applied to the input shaft at nominal input speed

*7 The maximum radial load that the gearbox can accept

*8 The maximum axial load that the gearbox can accept

*9 The efficiency at the nominal output torque ratings

*10 This does not include lost motion

*11 Contact Nidec Drive Technology for the testing conditions and environment

*12 Weight may vary slightly between models

PRF 120 2-Stage Specifications

Frame Size	120											
Ratio	Unit	Note	12	15	16	20	25	32	40	50	80	100
Nominal Output Torque	[Nm]	*1	225	225	330	330	330	330	330	280	280	225
Maximum Output Torque	[Nm]	*2	270	270	390	390	390	390	390	390	390	292
Emergency Stop Torque	[Nm]	*3	500	500	550	550	550	550	550	550	550	500
Nominal Input Speed	[rpm]	*4	3000									
Maximum Input Speed	[rpm]	*5	6000									
No Load Running Torque	[Nm]	*6	0.42									
Maximum Radial Load	[N]	*7	2000									
Maximum Axial Load	[N]	*8	2800									
Moment of Inertia ($\leq \varnothing 19$)	[kgcm ²]	--	1.32	1.08	1.07	0.93	0.92	1.03	0.76	0.80	0.79	0.79
Moment of Inertia ($\leq \varnothing 28$)	[kgcm ²]	--	3.31	2.97	3.06	2.93	2.91	3.03	2.75	2.78	2.78	2.78
Moment of Inertia ($\leq \varnothing 38$)	[kgcm ²]	--	-	-	-	-	-	-	-	-	-	-
Efficiency	[%]	*9	90									
Torsional Rigidity	[Nm/arc-min]	*10	15									
Maximum Torsional Backlash	[arc-min]	--	≤ 10									
Noise Level	dB [A]	*11	≤ 65									
Protection Class	*15	--	IP54									
Ambient Temperature	[°C]	--	0-40									
Permitted Housing Temperature	[°C]	--	90									
Weight	[kg]	*12	8.8									

*1 Continuous rating at 100% duty cycle, S1 operation, measured at 100rpm output and 30°C

*2 Permitted for 30,000 output shaft revolutions. Note operation factor on page 469

*3 The maximum torque allowed under a stress situation. Permitted 1,000 times during service life

*4 The average input speed at nominal torque. Maintain housing temperature below permitted value

*5 The maximum intermittent input speed

*6 Torque at no load applied to the input shaft at nominal input speed

*7 The maximum radial load that the gearbox can accept

*8 The maximum axial load that the gearbox can accept

*9 The efficiency at the nominal output torque ratings

*10 This does not include lost motion

*11 Contact Nidec Drive Technology for the testing conditions and environment

*12 Weight may vary slightly between models

VRSF

PRE

PRF

VRL

VRB

VRS

VRT

PLANETARY Inline Gear Reducers

PRF 120 1-Stage Dimensions

Input bore size $\leq \varnothing 19 \text{ mm}$

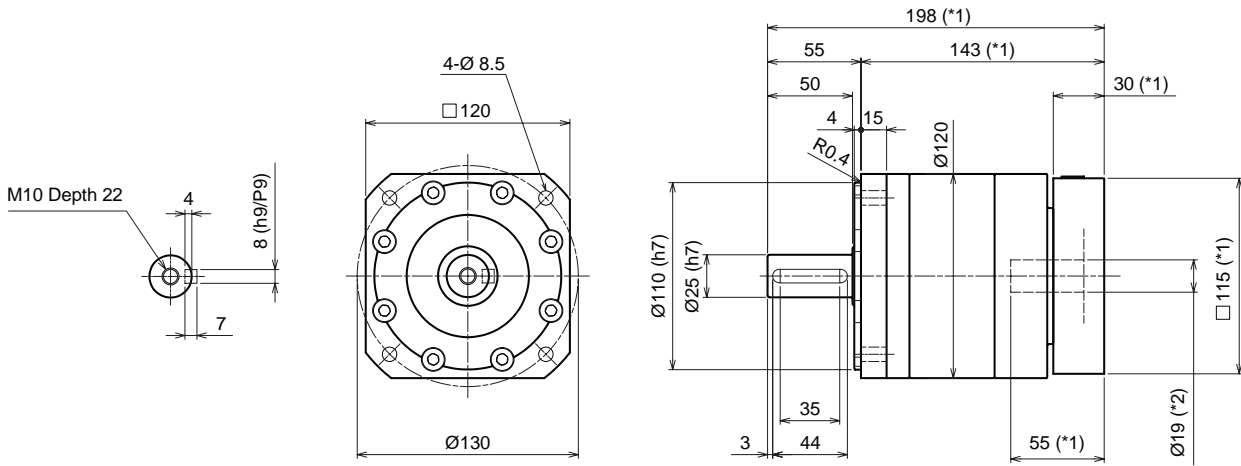

Input bore size $\leq \varnothing 28 \text{ mm}$

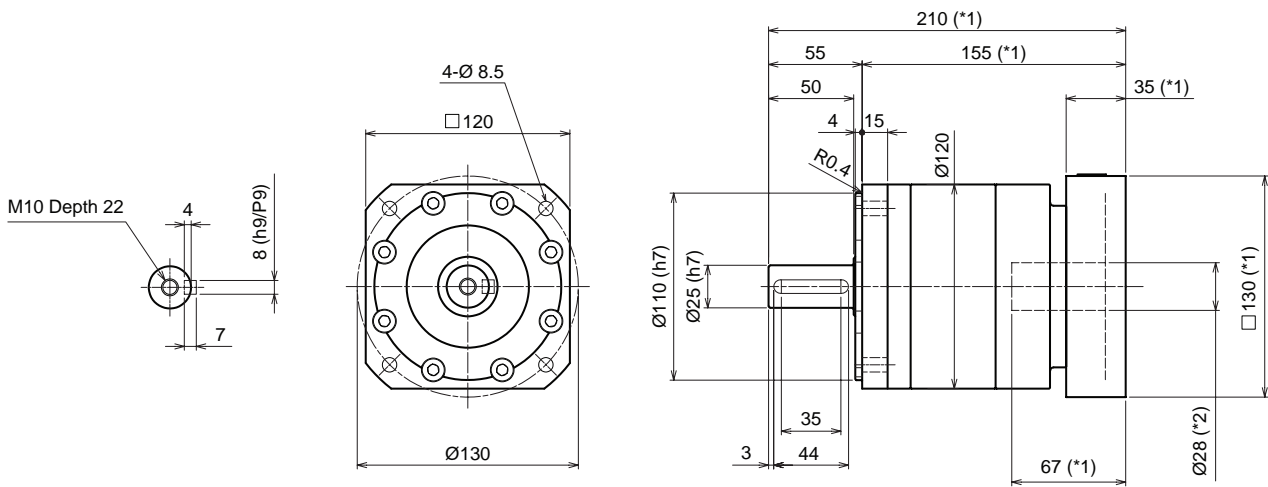

Input bore size $\leq \varnothing 38 \text{ mm}$

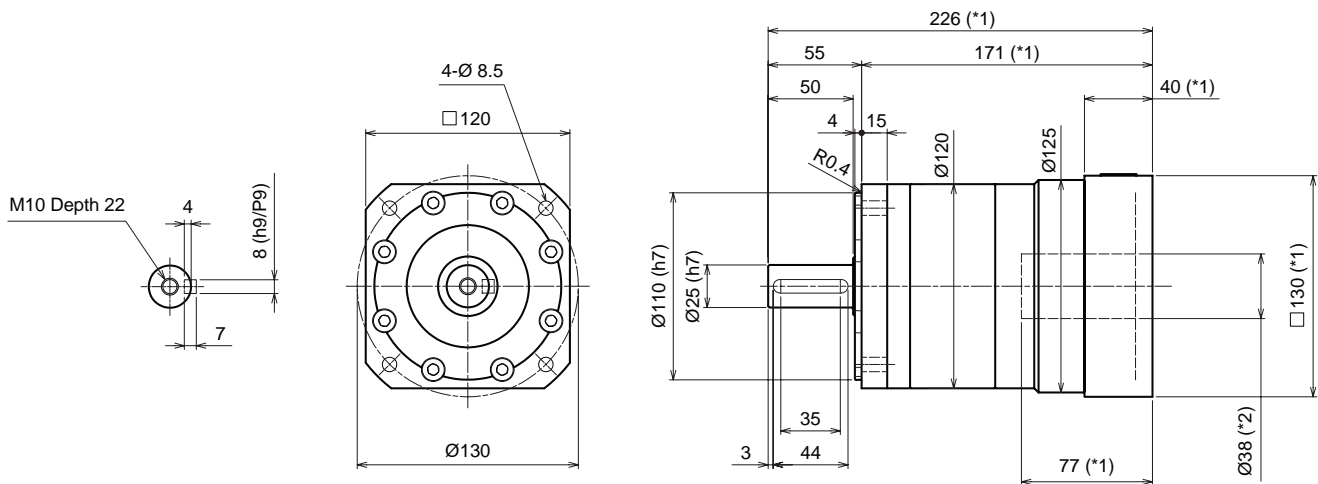

*1 Length will vary depending on motor

*2 Bushing will be inserted to adapt to motor shaft

PRF 120 2-Stage Dimensions

Input bore size $\leq \varnothing 19$ mm

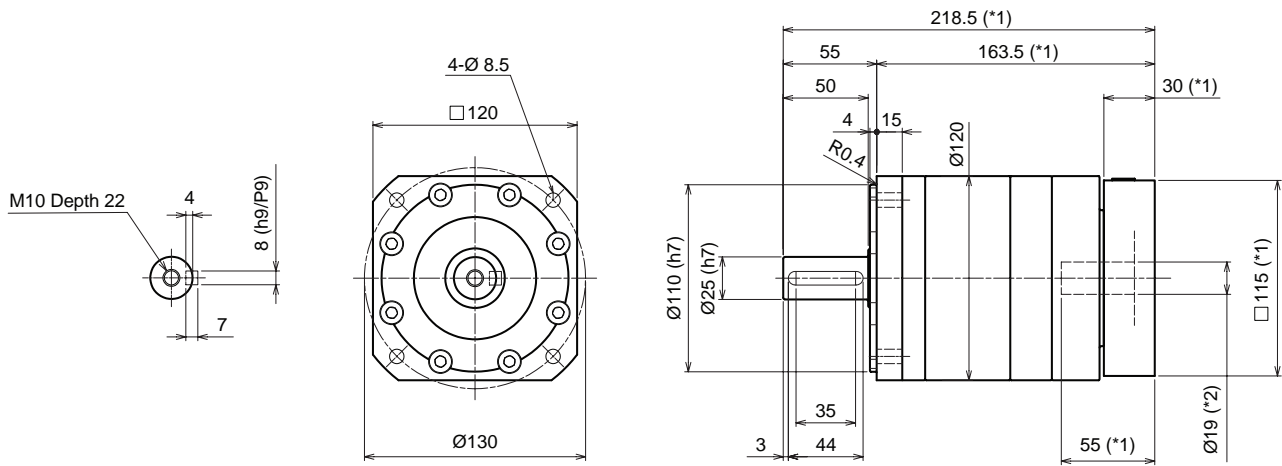

Input bore size $\leq \varnothing 28$ mm

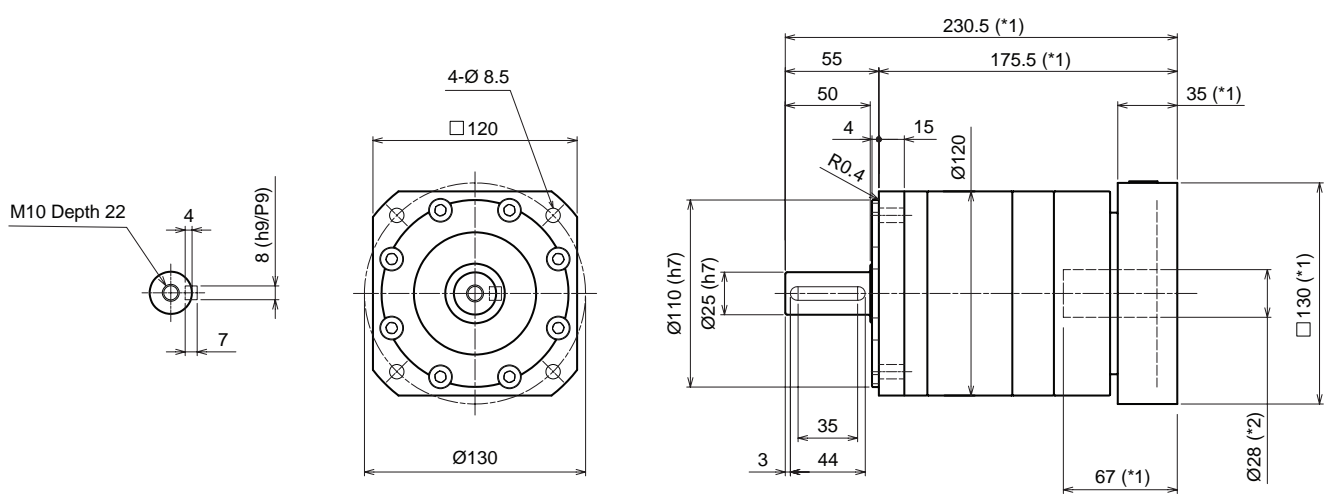

*1 Length will vary depending on motor

*2 Bushing will be inserted to adapt to motor shaft

VRSF

PRE

PRF

VRL

VRB

VRS

VRT

PRF 160 1-Stage Specifications

Frame Size	160							
Ratio	Unit	Note	3	4	5	8	9	10
Nominal Output Torque	[Nm]	*1	470	700	700	700	470	470
Maximum Output Torque	[Nm]	*2	630	1000	1000	950	730	730
Emergency Stop Torque	[Nm]	*3	1000	1250	1250	1250	1000	1000
Nominal Input Speed	[rpm]	*4	2000					
Maximum Input Speed	[rpm]	*5	6000					
No Load Running Torque	[Nm]	*6	1.63					
Maximum Radial Load	[N]	*7	6100					
Maximum Axial Load	[N]	*8	9000					
Moment of Inertia ($\leq \varnothing 28$)	[kgcm ²]	--	7.17	3.67	2.62	1.60	1.50	1.43
Moment of Inertia ($\leq \varnothing 38$)	[kgcm ²]	--	17.03	13.51	12.46	11.36	11.26	11.19
Efficiency	[%]	*9	95					
Torsional Rigidity	[Nm/arc-min]	*10	45					
Maximum Torsional Backlash	[arc-min]	--	≤ 8					
Noise Level	dB [A]	*11	≤ 70					
Protection Class	--	--	IP54					
Ambient Temperature	[°C]	--	0-40					
Permitted Housing Temperature	[°C]	--	90					
Weight	[kg]	*12	16.5					

*1 Continuous rating at 100% duty cycle, S1 operation, measured at 100rpm output and 30°C

*2 Permitted for 30,000 output shaft revolutions. Note operation factor on page 469

*3 The maximum torque allowed under a stress situation. Permitted 1,000 times during service life

*4 The average input speed at nominal torque. Maintain housing temperature below permitted value

*5 The maximum intermittent input speed

*6 Torque at no load applied to the input shaft at nominal input speed

*7 The maximum radial load that the gearbox can accept

*8 The maximum axial load that the gearbox can accept

*9 The efficiency at the nominal output torque ratings

*10 This does not include lost motion

*11 Contact Nidec Drive Technology for the testing conditions and environment

*12 Weight may vary slightly between models

PRF 160 2-Stage Specifications

Frame Size	160											
Ratio	Unit	Note	12	15	16	20	25	32	40	50	80	100
Nominal Output Torque	[Nm]	*1	470	470	700	700	700	700	700	700	700	470
Maximum Output Torque	[Nm]	*2	560	560	840	840	840	840	840	840	840	610
Emergency Stop Torque	[Nm]	*3	1000	1000	1250	1250	1250	1250	1250	1250	1250	1000
Nominal Input Speed	[rpm]	*4	2000									
Maximum Input Speed	[rpm]	*5	6000									
No Load Running Torque	[Nm]	*6	0.56									
Maximum Radial Load	[N]	*7	6100									
Maximum Axial Load	[N]	*8	9000									
Moment of Inertia ($\leq \varnothing 28$)	[kgcm ²]	--	5.41	2.50	2.55	1.94	1.89	2.42	1.23	3.11	3.09	3.09
Moment of Inertia ($\leq \varnothing 38$)	[kgcm ²]	--	14.00	12.09	12.54	11.92	11.87	12.41	11.17	11.90	11.90	11.90
Efficiency	[%]	*9	90									
Torsional Rigidity	[Nm/arc-min]	*10	43									
Maximum Torsional Backlash	[arc-min]	--	≤ 10									
Noise Level	dB [A]	*11	≤ 70									
Protection Class	--	--	IP54									
Ambient Temperature	[°C]	--	0-40									
Permitted Housing Temperature	[°C]	--	90									
Weight	[kg]	*12	20.3									

- *1 Continuous rating at 100% duty cycle, S1 operation, measured at 100rpm output and 30°C
- *2 Permitted for 30,000 output shaft revolutions. Note operation factor on page 469
- *3 The maximum torque allowed under a stress situation. Permitted 1,000 times during service life
- *4 The average input speed at nominal torque. Maintain housing temperature below permitted value
- *5 The maximum intermittent input speed
- *6 Torque at no load applied to the input shaft at nominal input speed
- *7 The maximum radial load that the gearbox can accept
- *8 The maximum axial load that the gearbox can accept
- *9 The efficiency at the nominal output torque ratings
- *10 This does not include lost motion
- *11 Contact Nidec Drive Technology for the testing conditions and environment
- *12 Weight may vary slightly between models

VRSF

PRE

PRF

VRL

VRB

VRS

VRT

PRF 160 1-Stage Dimensions

Input bore size $\leq \varnothing 28$ mm

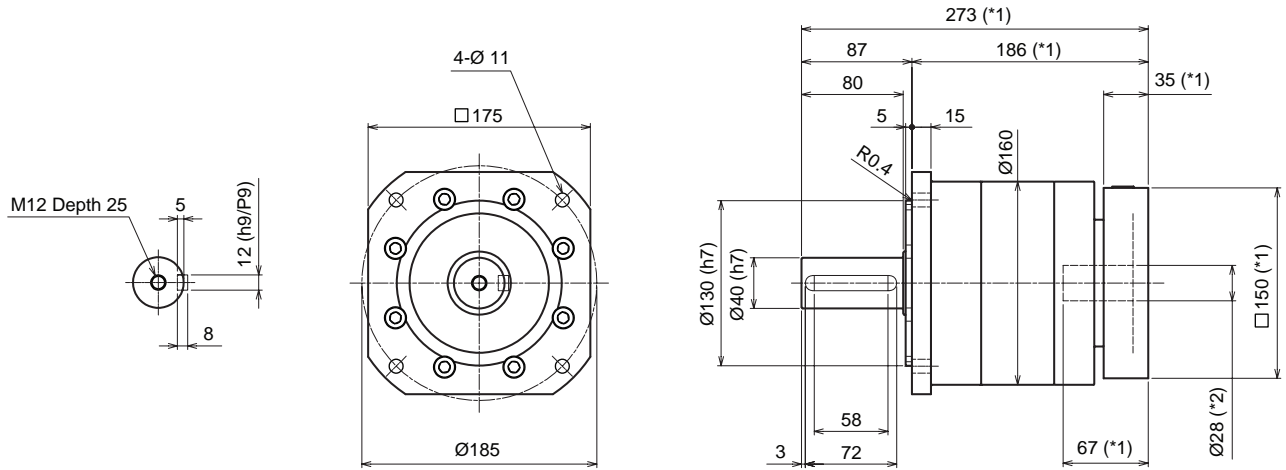

Input bore size $\leq \varnothing 38$ mm

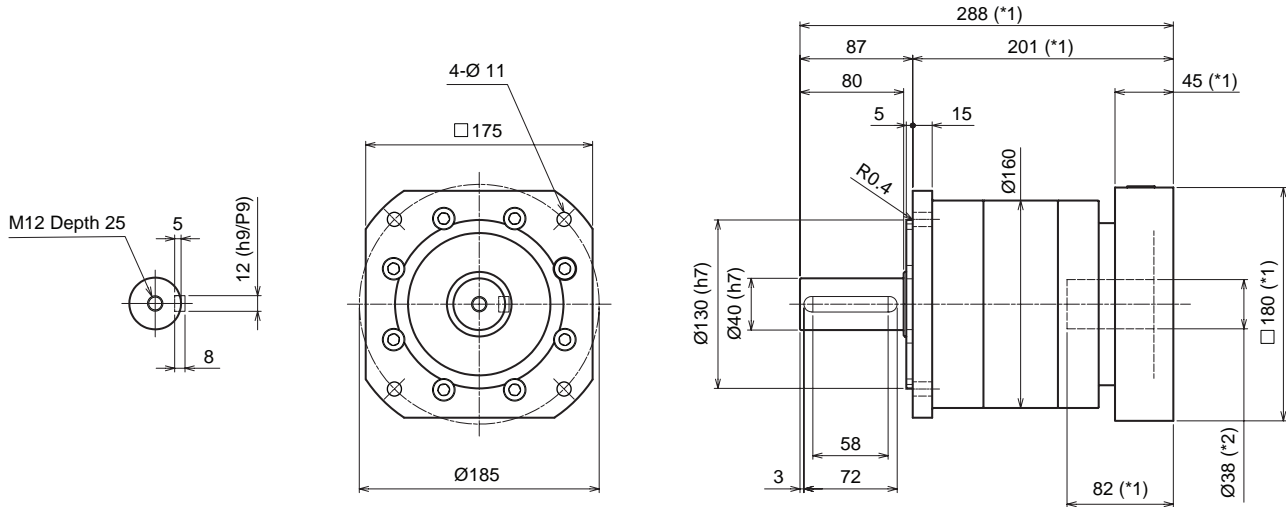

*1 Length will vary depending on motor

*2 Bushing will be inserted to adapt to motor shaft

PRF 160 2-Stage Dimensions

Input bore size $\leq \varnothing 28$ mm

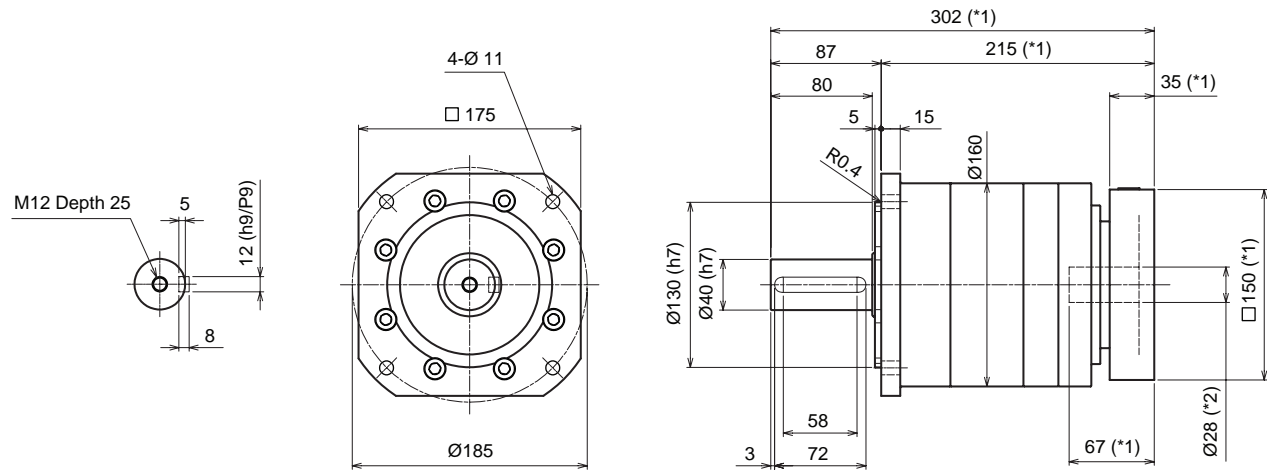

Input bore size $\leq \varnothing 38$ mm

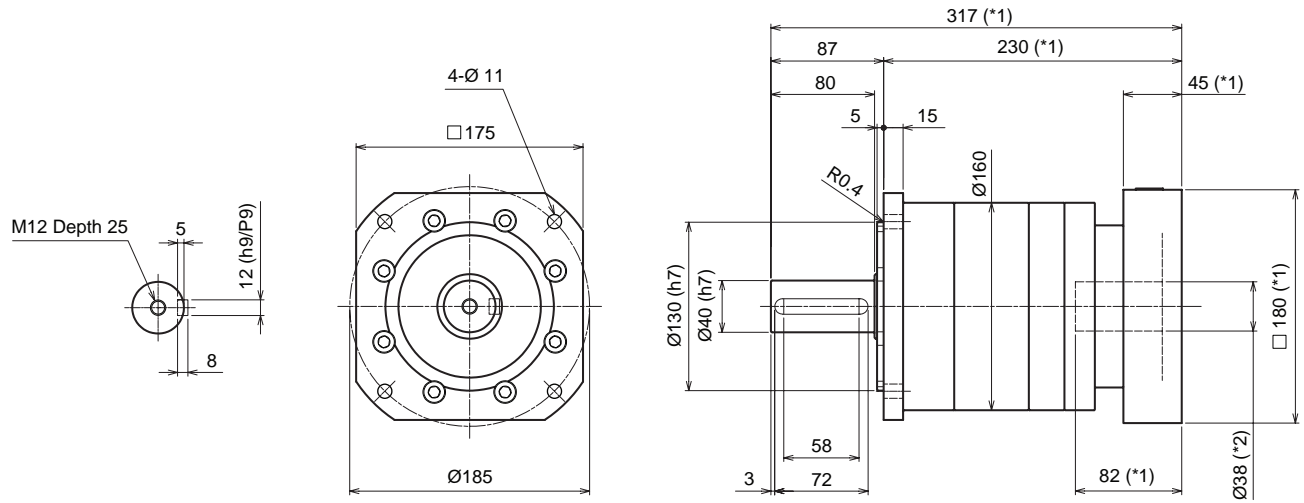

*1 Length will vary depending on motor

*2 Bushing will be inserted to adapt to motor shaft

VRSF

PRE

PRF

VR

VRB

VRS

VRT