

Nidec

FLEXWAVE

The Next Generation

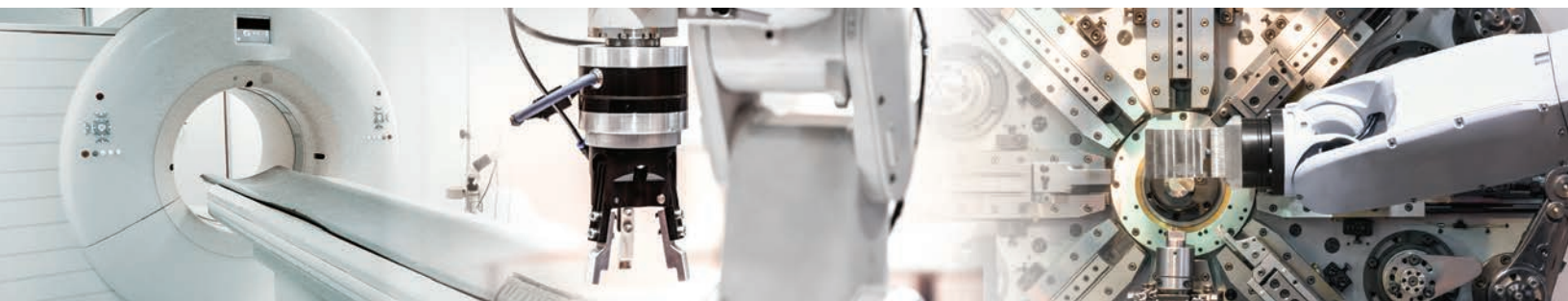

WP Series
The Highest Precision

NIDEC DRIVE TECHNOLOGY CORPORATION

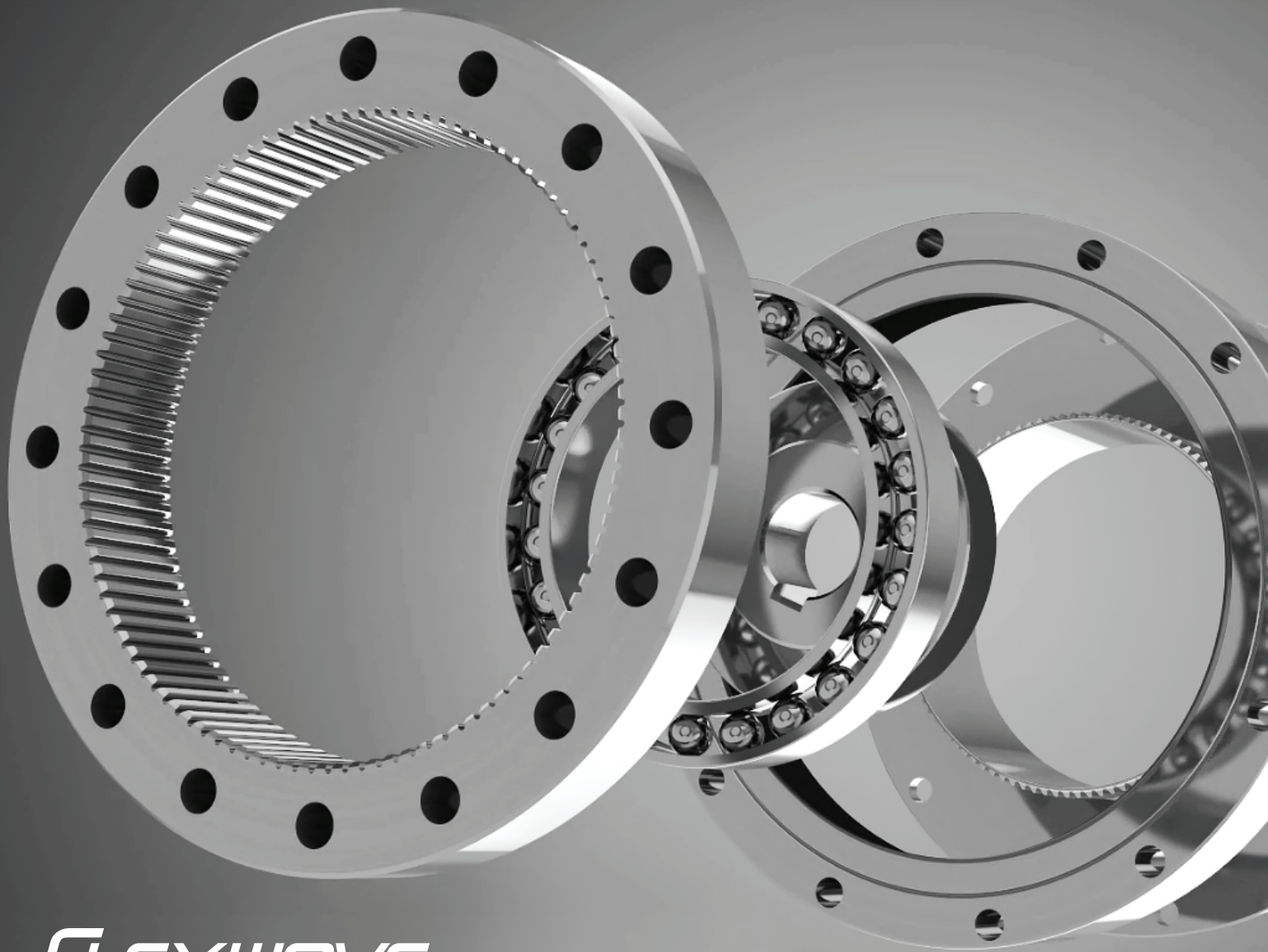

FLEXWAVE

Relentless Refinement of Technology

The *Next Generation* Nidec FLEXWAVE high precision gear reducers offer machine designers virtually unlimited flexibility and adaptability when designing highly innovative drive mechanisms. Standard configurations include; component sets, self-contained assemblies, and complete gear units ready to mount to standard servomotors with pre-assembled innovative standard motor mounting kits.

The *Next Generation* Nidec FLEXWAVE optimized tooth profiles combined with the Nidec Corporation core competencies of manufacturing high precision components at scale offer the most robust solutions with the highest reliability rates available to meet the most demanding application requirements where performance is guaranteed.

The *Next Generation* Nidec FLEXWAVE Cup style and Top Hat style Flex gears combined with solid or hollow input shafts extend the possibilities for integrating into unique designs with Ultra Flat versions available for when space is tight and High Torque versions for the more demanding applications requiring high torque density.

Index

Lineup / Parts Configuration.....	2
Strain Wave Technology.....	3
Model Selection.....	4

■ High Torque Type B2

Reducer Model / Specifications.....	5
Dimensions.....	6
Life Estimation (Elastic Bearing).....	11
Life Estimation (Main Bearing).....	12
Maximum Load at Input Shaft.....	14
Lubricant Information.....	15
Attachment Fixture Requirement.....	16
Transmitting Torque.....	17
Input Section Structure.....	20
Installation & Assembly Instructions.....	21
Motor Installation Procedure.....	22
Characteristics Data.....	23

■ Flat Type D

Reducer Model / Specifications.....	46
Dimensions.....	47
Life Estimation (Elastic Bearing).....	52
Life Estimation (Main Bearing).....	53
Maximum Load at Input Shaft.....	54
Lubricant Information.....	55
Attachment Fixture Requirement.....	56
Transmitting Torque.....	57
Installation & Assembly Instructions.....	59
Characteristics Data.....	60

■ Gearhead Type

Reducer Model / Specifications.....	68
Dimensions.....	69
Life Estimation (Elastic Bearing).....	74
Life Estimation (Main Bearing).....	74
Lubricant Information.....	75
Transmitting Torque.....	75



All *Next Generation* Nidec FLEXWAVE high precision gear reducers are fully interchangeable with industry standards allowing designers to upgrade performance to existing designs by simply changing part numbers on the bills of materials.

- Exceptional Repeatability and Positional Accuracy
- Zero Backlash
- High Torque Density
- High Efficiency Ratings
- Lightweight and Compact
- High Torsional Stiffness

The *Next Generation* Nidec FLEXWAVE - proving to be the superior choice for the next generation drive mechanisms in Robotics, Machine Tool, Medical Equipment, Semiconductor Manufacturing, Satellite Communications and Assembly Automation applications.

FLEXWAVE Lineup

Open type



Hollow unit
WPU-□-□-SDH
WPU-□-□-SRH



Input shaft unit
WPU-□-□-SRJ



Simple unit
WPS-□-□-SD
WPS-□-□-SR

Closed type

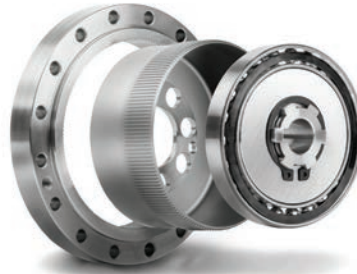

Component
WPC-□-□-CR
WPC-□-□-CD



Unit
WPU-□-□-CR
WPU-□-□-CD
WPU-□-□-CDH



Gearhead
WPG-□-□-CR

Parts configuration

Flex gear (thin / flexible)

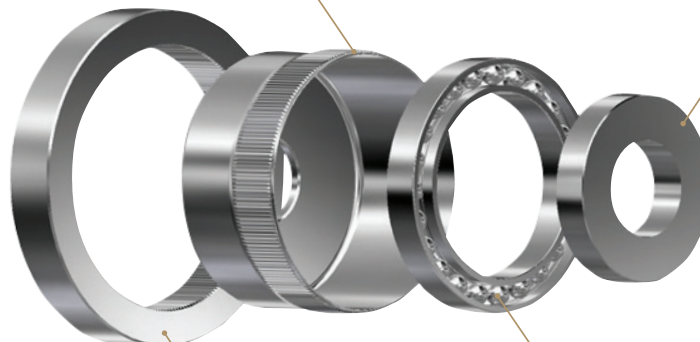

Cam (elliptic)

Elastic bearing (thin / flexible)

Internal gear

Strain Wave Technology

Reduction mechanism

- Flex gear and elastic bearing take elliptic shape with cam inserted.
- Elliptical cam input is inserted into Flex gear and then mounted into internal gear; the flex gear engages the internal gear in 2 locations 180° apart. This allows for high torque in a compact stable manner.
- With internal gear fixed and cam (input) rotated clockwise, the flex gear (output) rotates counter clockwise. Direction and speed of rotation is determined by tooth count of gears and mounting geometry.

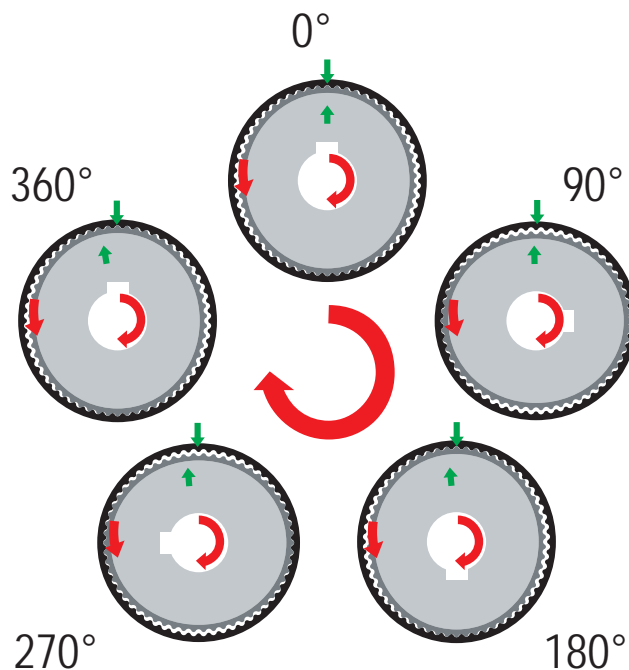

Closed type

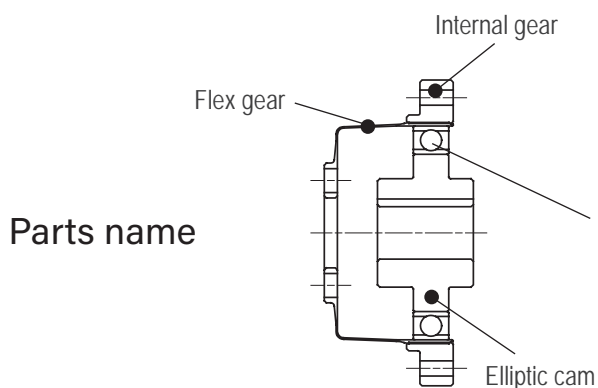

Parts name

Open type

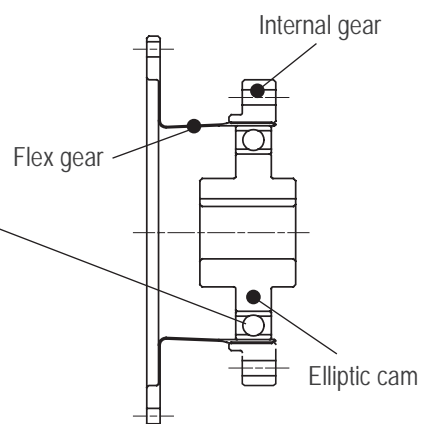

Reduction ratio

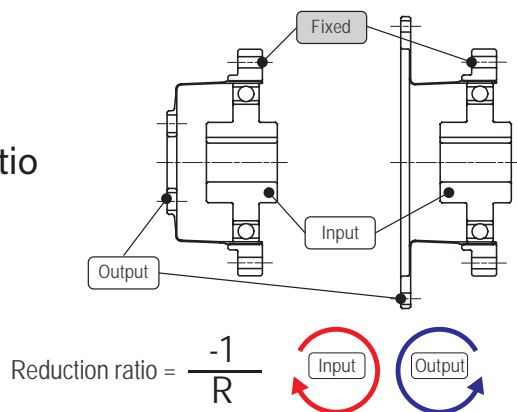

* The input and output rotation directions are opposite.

* "R" represents the "Ratio" figure in the specifications table on the next page.

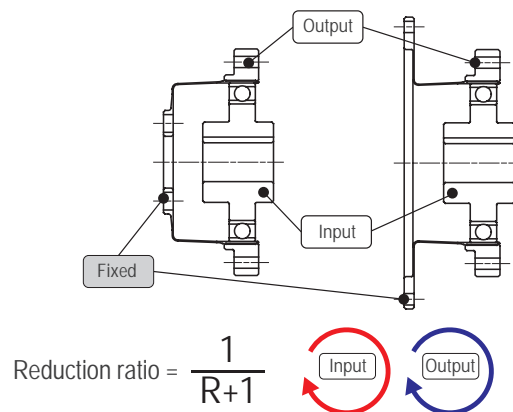

* The input and output rotation directions are same.

Model Selection

Model Selection Flow

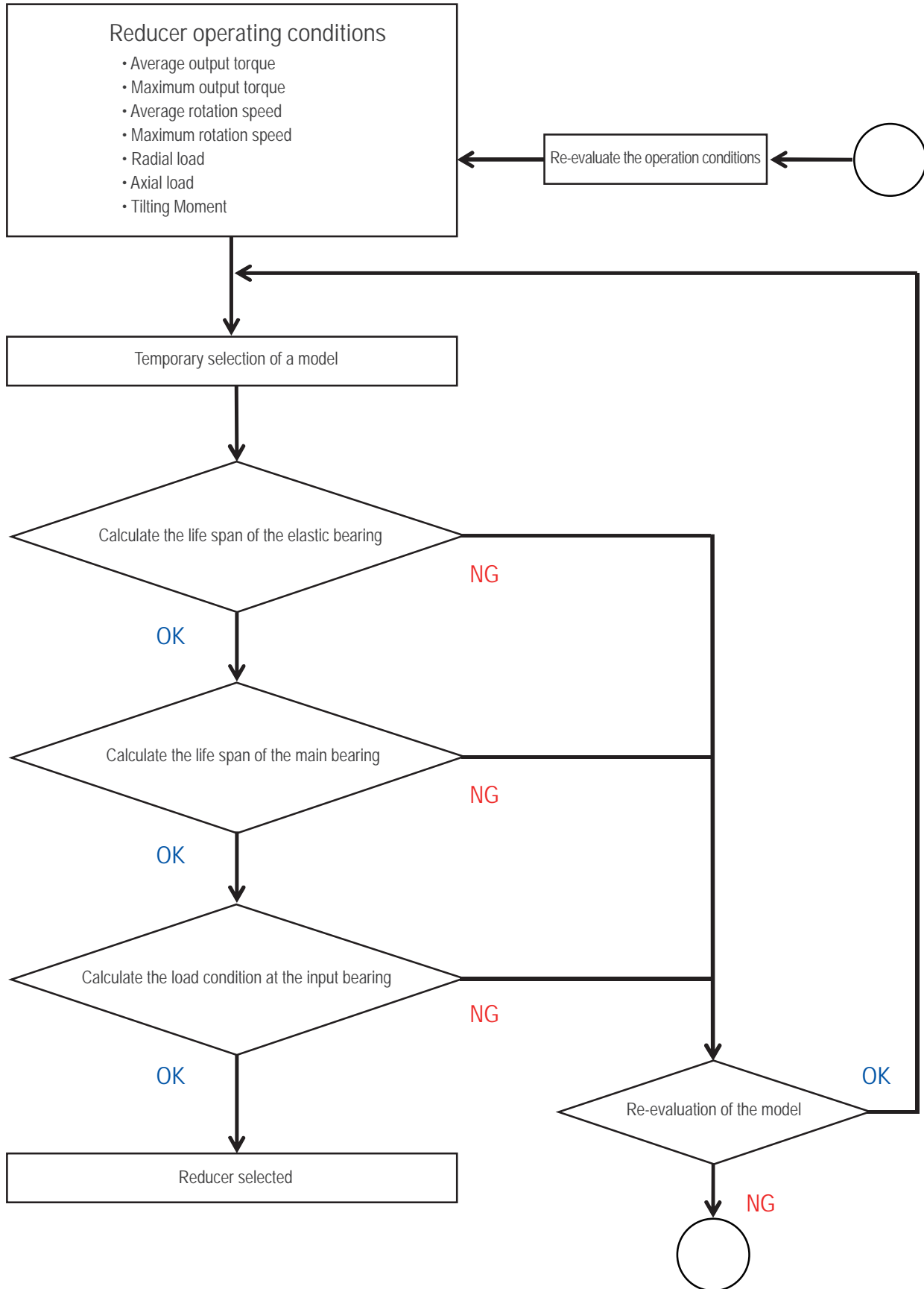

Reducer Model Nomenclature

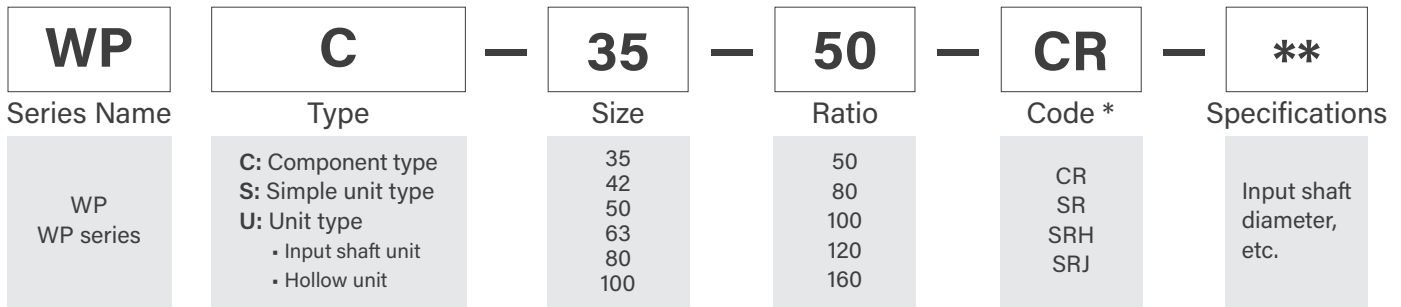

Ratio Matrix Availability

Frame Size	Reduction Ratio				
	50	80	100	120	160
35					
42					
50					
63					
80					
100					

* For code details, check Dimensions Table

Reducer Specifications

Frame	Ratio R*1	Nominal Output Torque *2	Maximum Output Torque *3	Emergency Stop Torque *4	Nominal Input Speed *5	Maximum Input Speed *6	Life *7
		[Nm]	[Nm]	[Nm]	[r/min]	[r/min]	[hours]
35	50	7	23	46	3000	8500	10000
	80	10	30	61			
	100	10	36	70			
42	50	21	44	91	3000	7300	
	80	29	56	113			
	100	31	70	143			
	120	31	70	112			
50	50	33	73	127	3000	6500	
	80	44	96	165			
	100	52	107	191			
	120	52	113	191			
	160	52	120	191			
63	50	51	127	242	3000	5600	
	80	82	178	332			
	100	87	204	369			
	120	87	217	395			
	160	87	229	408			
80	50	99	281	497	3000	4800	
	80	153	395	738			
	100	178	433	841			
	120	178	459	892			
	160	178	484	892			
100*	50	178	523	892	3000	4000	
	80	268	675	1270			
	100	345	738	1400			
	120	382	802	1530			
	160	382	841	1530			

*1 Reduction ratio is to be calculated by the formula in the previous page, using R value in this table.

*2 The maximum allowable value at the input rotation speed of 2000r/min

*3 The maximum torque when starting and stopping.

*4 The maximum torque when it receives shock.

*5 The maximum average input speed.

*6 The maximum input speed.

*7 The life time at the input rotation speed of 2000 r/min and nominal output torque.

* 100 frame option is currently only available for open type

* 100 frame option is available for **S**: Simple unit type and **U**: Unit type (Input shaft unit) and (Hollow shaft)

Reducer Model/ Specifications
Dimensions
Life Estimation (Elastic Bearing)
Life Estimation (Main Bearing)
Maximum Load at Input Shaft
Lubricant Information
Attachment Fixture Requirement Info
Transmitting Torque
Input Section Structure/ Installation & Assembly
Motor Installation Procedure Info
Characteristics Data

Dimensions

Closed Type: Component

WPC-□-□-CR

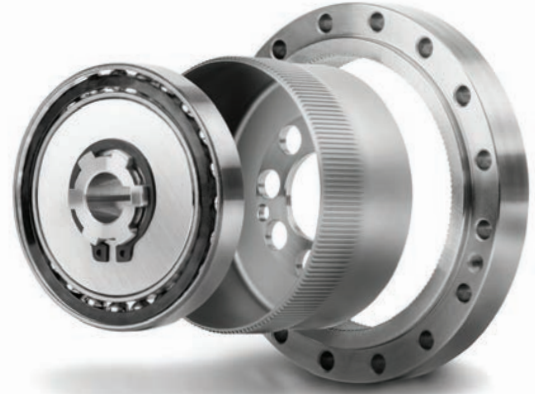

Size	Weight	Moment of Inertia
	kg	$\times 10^{-4} \text{kgm}^2$
35	0.10	0.0362
42	0.17	0.0831
50	0.26	0.190
63	0.43	0.414
80	0.91	1.54

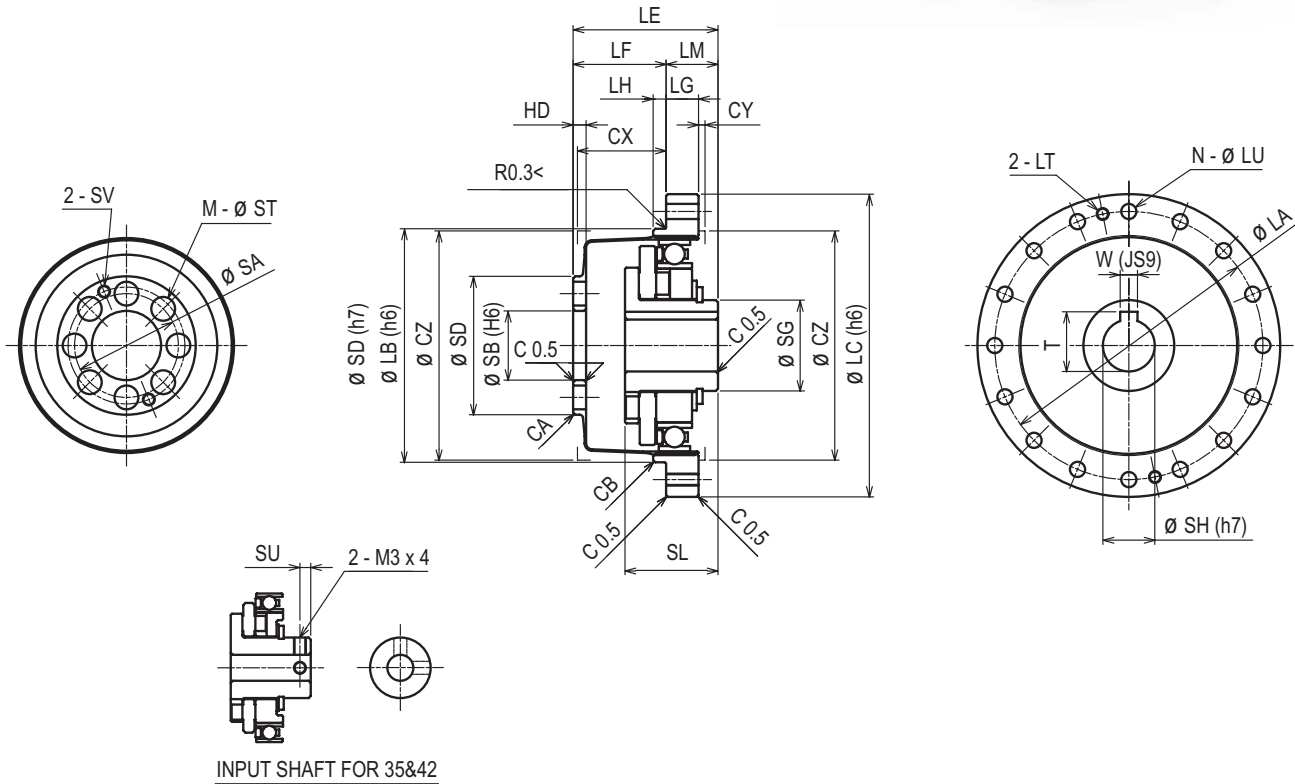

[mm]

Size	LA	LB	LC	N	LU	LT	LE	LF	LG	LH	LM	SG	SH	SL	W
35	44	38	50	8	3.5	M3	28.5	17.5	6	2	11	14	6	18.5	-
42	54	48	60	16	3.5	M3	32.5	20	6.5	2.5	12.5	18	8	20.7	-
50	62	54	70	16	3.5	M3	33.5	21.5	7.5	3	12	21	12	21.5	4
63	75	67	85	16	4.5	M4	37	24	10	3	13	26	14	21.6	5
80	100	90	110	16	5.5	M5	44	28	14	3	16	26	14	23.6	5

Size	T	SU	SA	SB	SD	M	ST	SV	HD	CA	CB	CX	CY	CZ
35	-	2.5	17	11	23	6	4.5	M3	2.4	C0.3	C0.3	17.1	1	38
42	-	3	19	10	27.2	6	5.5	M3	3	C0.5	C0.3	19	1	45
50	13.8	-	24	16	32	8	5.5	M3	3	C0.5	C0.3	20.5	1.5	53
63	16.3	-	30	20	40	8	6.5	M4	3	C0.5	C0.3	23	1.5	66
80	16.3	-	40	26	52	8	8.8	M5	3.2	C0.5	C0.5	26.8	1.5	86

*1 For details in the input section, please check the drawings.

*2 Inner dimensions of CX, CY, CZ are recommended dimensions.

Dimensions

Closed Type: Unit

WPU-□-□-CR

Size	Weight	Moment of Inertia
	kg	$\times 10^{-4} \text{kgm}^2$
35	0.50	0.0362
42	0.68	0.0831
50	0.95	0.190
63	1.5	0.414
80	3.3	1.54

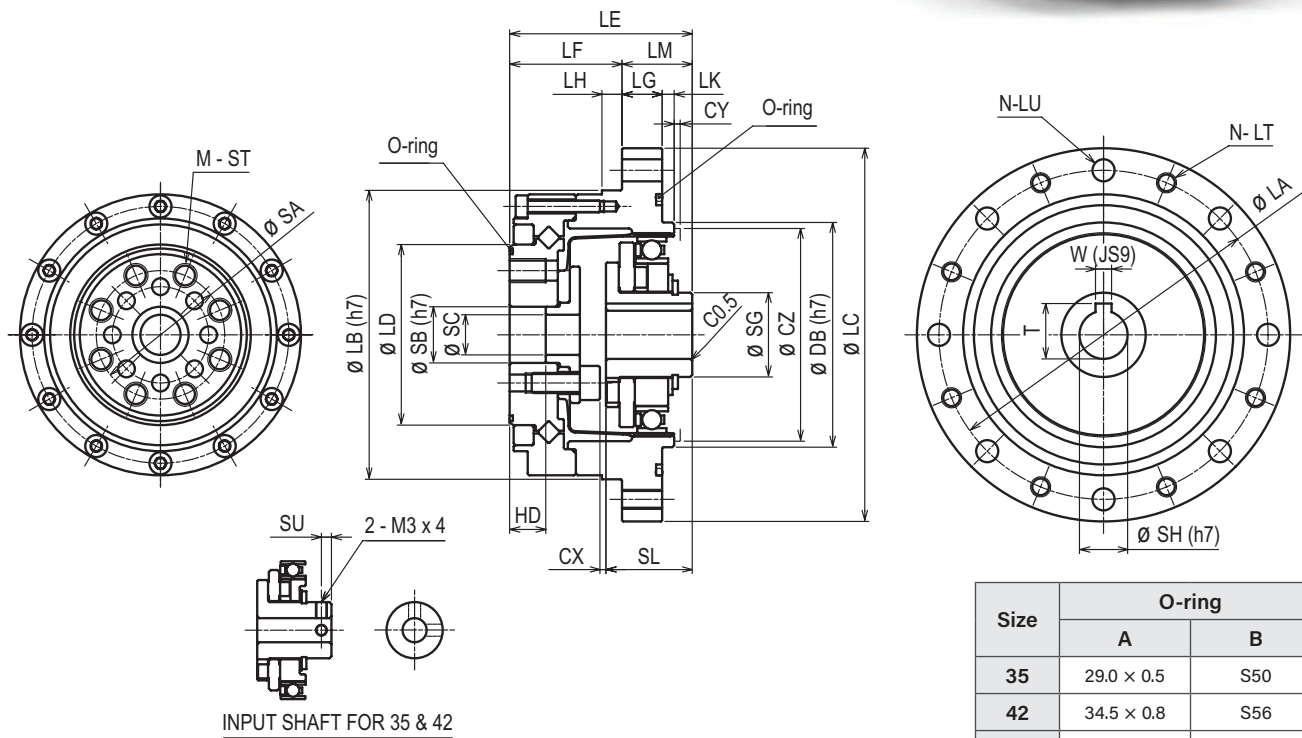

INPUT SHAFT FOR 35 & 42

Size	O-ring	
	A	B
35	29.0 × 0.5	S50
42	34.5 × 0.8	S56
50	40.64 × 1.14	S67
63	53.29 × 0.99	S80
80	S71	S105

[mm]

Size	LA	LB	LC	LD	N	LT	LU	LE	LF	LG	LH	LK	LM	DB	SG
35	65	56	73	31	8	M4	4.5	41	27	7	3.5	2	14	38	14
42	71	63	79	38	8	M4	4.5	45	29	8	4	2	16	48	18
50	82	72	93	45	8	M5	5.5	45.5	28	10	5	3	17.5	56	21
63	96	86	107	58	10	M5	5.5	52	36	10	5	3	16	67	26
80	125	113	138	78	12	M6	6.5	62	45	12	5	3	17	90	26

Size	SH	SL	W	T	SU	SA	SB	SC	M	ST	HD	CX	CY	CZ
35	6	18.5	-	-	2.5	23	11	8	6	M4 × 8	9.5	1.6	1	38
42	8	20.7	-	-	3	27	10	7	6	M5 × 8	9.5	1.3	1	45
50	12	21.5	4	13.8	-	32	14	10	8	M6 × 9	9	1.5	1.5	53
63	14	21.6	5	16.3	-	42	20	15	8	M8 × 10	12	3.4	1.5	66
80	14	23.6	5	16.3	-	55	26	20	8	M10 × 12	15	5.2	1.5	86

*1 For details in the input section, please check the drawings.

*2 Inner dimensions of CY, CZ are recommended dimensions.

Reducer Model/
Specifications

Dimensions

Life Estimation
(Elastic Bearing)

Life Estimation
(Main Bearing)

Maximum Load
at Input Shaft

Lubricant Information

Attachment Fixture
Requirement Info

Transmitting Torque

Input Section Structure/
Installation & Assembly

Motor Installation
Procedure Info

Characteristics Data

Dimensions

Open Type: Simple Unit

WPS-□-□-SR



Size	Weight	Moment of Inertia
	kg	$\times 10^{-4} \text{kgm}^2$
35	0.39	0.0362
42	0.55	0.0831
50	0.79	0.190
63	1.3	0.414
80	2.7	1.54
100	4.5	3.11

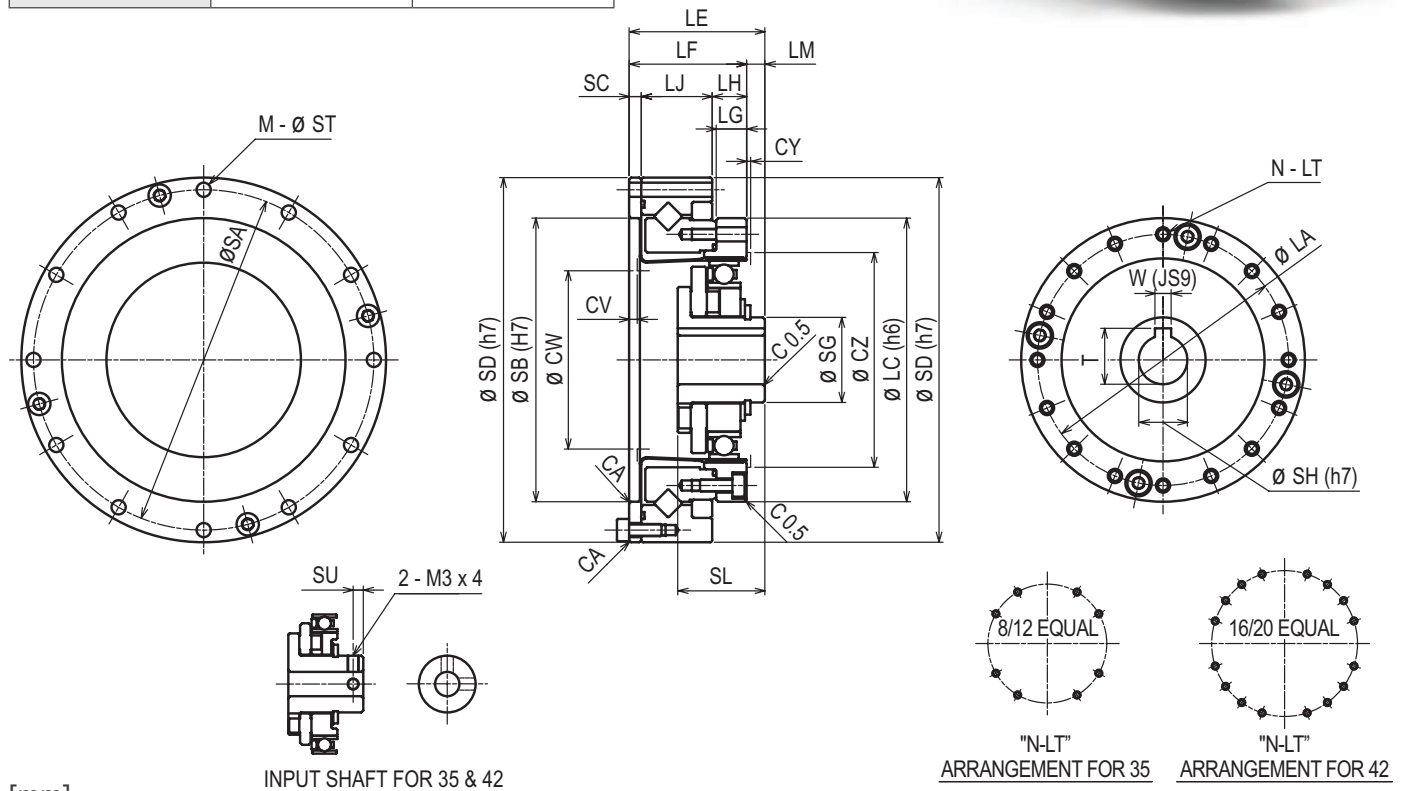

[mm]

INPUT SHAFT FOR 35 & 42

"N-LT" ARRANGEMENT FOR 35

"N-LT" ARRANGEMENT FOR 42

Size	LA	LC	LE	LF	LG	LH	LJ	LM	SG	SH	SL	W	T	SU	SA	SB
35	44	50	28.5	23.5	6	7	14.1	5	14	6	18.5	-	-	2.5	64	48
42	54	60	32.5	26.5	6.5	7.5	16	6	18	8	20.7	-	-	3	74	60
50	62	70	33.5	29	7.5	8.5	17.5	4.5	21	12	21.5	4	13.8	-	84	70
63	77	85	37	34	10	12	18.7	3	26	14	21.6	5	16.3	-	102	88
80	100	110	44	42	14	15	23.4	2	26	14	23.6	5	16.3	-	132	114
100	122	135	53.6	51	17	18	29	2	32	16	29.7	5	18.3	-	158	140

Size	SC	SD	M	ST	CA	CY	CZ	CV	CW	N	LT
35	2.4	70	8	3.5	C0.4	1	38	1.7	31	8	M3 × 5, ∅ 3.5 × 6
42	3	80	12	3.5	C0.4	1	45	2.1	38	16	M3 × 6, ∅ 3.5 × 6.5
50	3	90	12	3.5	C0.4	1.5	53	2	45	16	M3 × 6, ∅ 3.5 × 7.5
63	3.3	110	12	4.5	C0.4	1.5	66	2	56	16	M4 × 7, ∅ 4.5 × 10
80	3.6	142	12	5.5	C0.4	1.5	86	2	73	16	M5 × 8, ∅ 5.5 × 14
100	4	170	12	6.6	C0.4	2	106	2	90	16	M6 × 10, ∅ 6.6 × 17

*1 For details in the input section, please check the drawings.

*2 Inner dimensions of CV, CW, CY, CZ are recommended dimensions.

Dimensions

Open Type: Unit (Hollow Shaft)

WPU-□-□-SRH

Size	Weight	Moment of Inertia
	kg	$\times 10^{-4} \text{kgm}^2$
35	0.72	0.0924
42	1.0	0.207
50	1.4	0.408
63	2.1	1.06
80	4.2	2.72
100	7.2	8.66

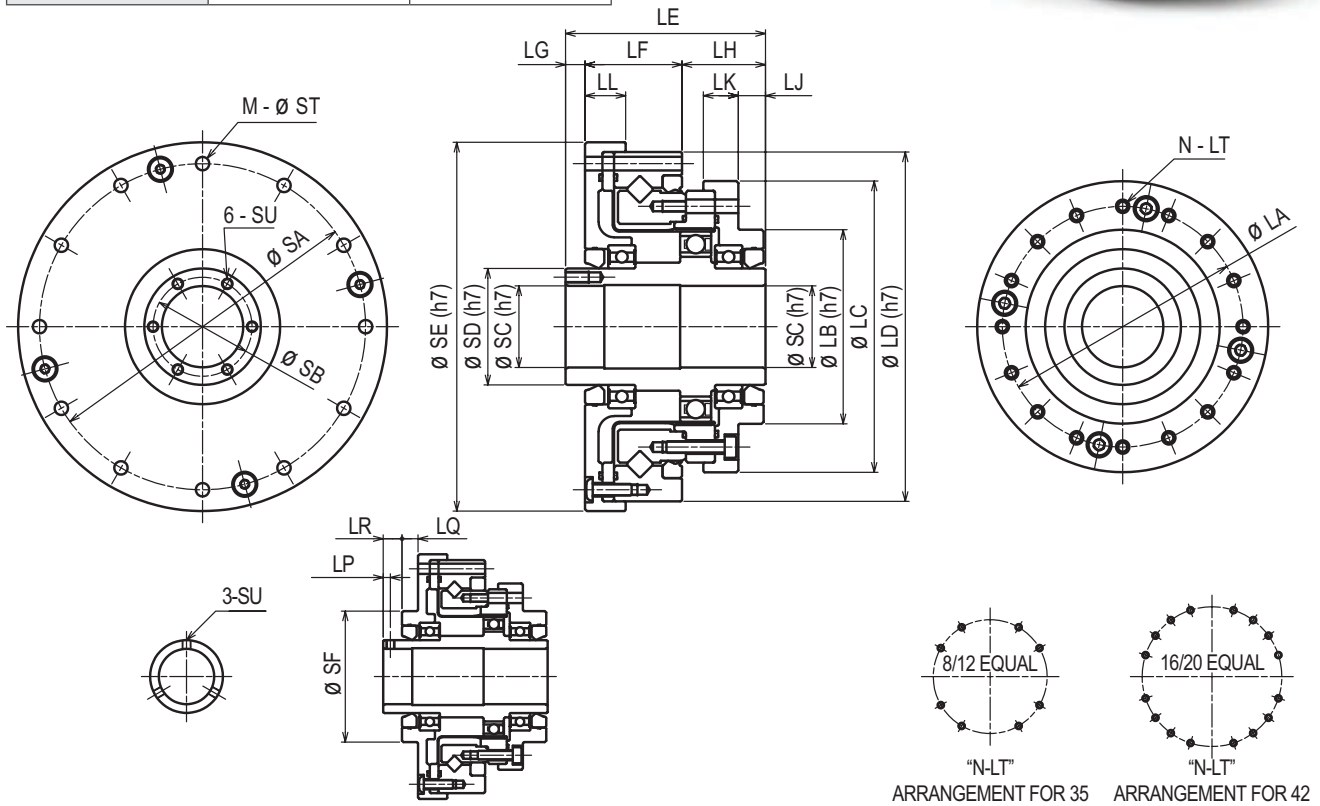

[mm]

INPUT SHAFT FOR 35 & 42

Size	LA	LB	LC	LD	LE	LF	LG	LH	LJ	LK	LL	LP	LQ	LR
-	44	36	54	70	52.5	20.5	12	20	7.5	8	9	2.5	5.5	6.5
42	54	45	64	80	56.5	23	12	21.5	8.5	8.5	10	2.5	5.5	6.5
50	62	50	75	90	51.5	25	5	21.5	7	9	10.5	-	-	-
63	77	60	90	110	55.5	26	6	23.5	6	8.5	10.5	-	-	-
80	100	85	115	142	65.5	32	7	26.5	5	9.5	12	-	-	-
100	122	100	140	170	79	38	8	33	7	13	14	-	-	-

Size	SA	SB	SC	SD	SE	SF	M	ST	SU	N	LT
35	64	-	14	20	74	36	8	3.5	M3	8	M3 × 5, Ø 3.5 × 11.5
42	74	-	19	25	84	45	12	3.5	M3	16	M3 × 6, Ø 3.5 × 12
50	84	25.5	21	30	95	-	12	3.5	M3 × 6	16	M3 × 6, Ø 3.5 × 13.5
63	102	33.5	29	38	115	-	12	4.5	M3 × 6	16	M4 × 7, Ø 4.5 × 15.5
80	132	40.5	36	45	147	-	12	5.5	M3 × 6	16	M5 × 8, Ø 5.5 × 20.5
100	158	52	46	59	175	-	12	6.6	M4 × 8	16	M6 × 10, Ø 6.6 × 25

Reducer Model/ Specifications
 Dimensions
 Life Estimation (Elastic Bearing)
 Life Estimation (Main Bearing)
 Maximum Load at Input Shaft
 Lubricant Information
 Attachment Fixture Requirement Info
 Transmitting Torque
 Input Section Structure/ Installation & Assembly
 Motor Installation Procedure Info
 Characteristics Data

Dimensions

Open Type: Unit (Input Shaft)

WPU-□-□-SRJ

Size	Weight	Moment of Inertia
	kg	$\times 10^{-4} \text{kgm}^2$
35	0.65	0.0266
42	0.91	0.0666
50	1.4	0.155
63	2.1	0.382
80	4.1	1.28
100	6.9	3.15

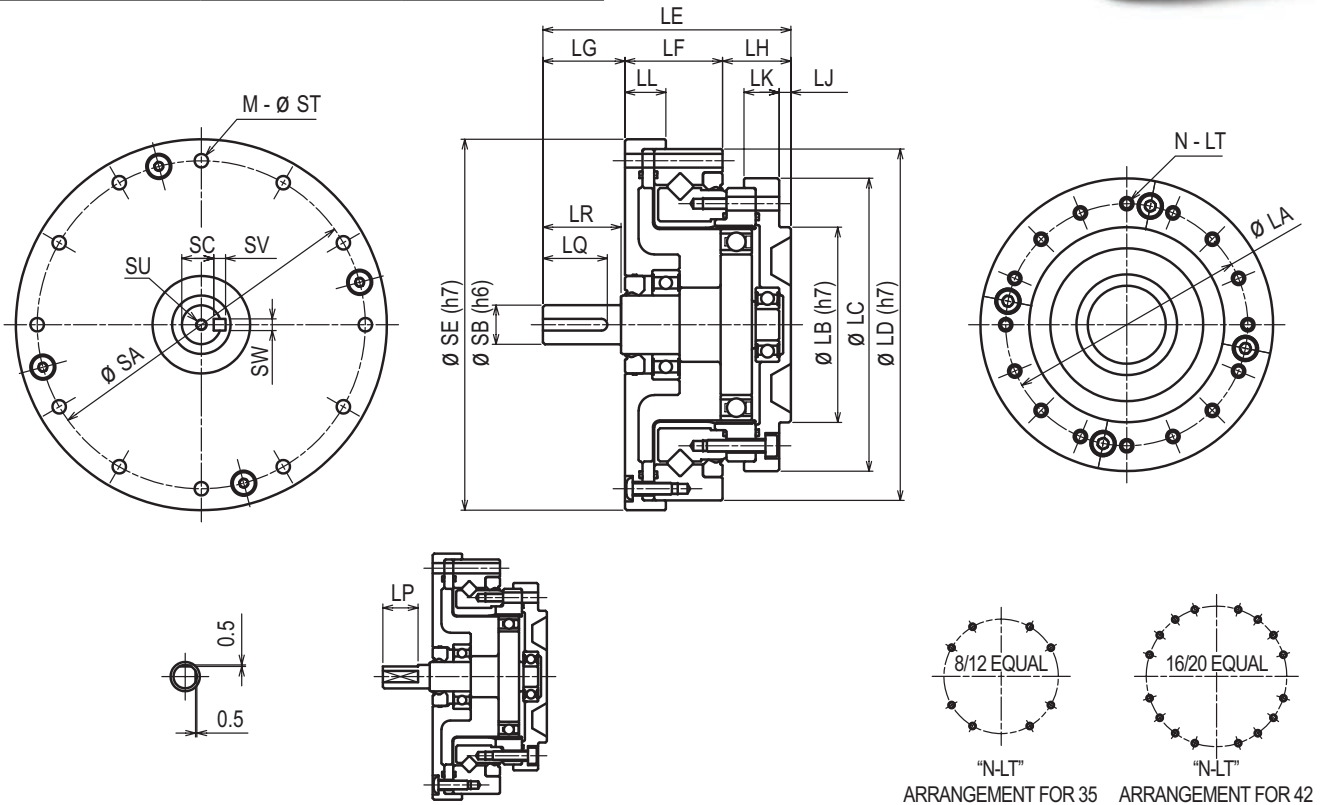
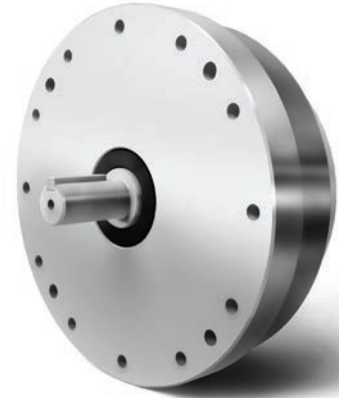

INPUT SHAFT FOR 35 & 42

[mm]

Size	LA	LB	LC	LD	LE	LF	LG	LH	LJ	LK	LL	LP	LQ	LR
35	44	36	54	70	50.5	20.5	15	15	2.5	8	9	11	-	-
42	54	45	64	80	56	23	17	16	3	8.5	10	12	-	-
50	62	50	75	90	63.5	25	21	17.5	3	9	10.5	-	16.5	20
63	77	60	90	110	72.5	26	26	20.5	3	8.5	10.5	-	22.5	25
80	100	85	115	142	84.5	32	26	26.5	5	9.5	12	-	22.5	25
100	122	100	140	170	100	38	31	31	5	13	14	-	27.5	30

Size	SA	SB	SC	SE	SV	SW	M	ST	SU	N	LT
35	64	6	-	74	-	-	8	3.5	-	8	M3 × 5, Ø 3.5 × 11.5
42	74	8	-	84	-	-	12	3.5	-	16	M3 × 6, Ø 3.5 × 12
50	84	10	8.2	95	3	3	12	3.5	M3 × 6	16	M3 × 6, Ø 3.5 × 13.5
63	102	14	11	115	5	5	12	4.5	M5 × 10	16	M4 × 7, Ø 4.5 × 15.5
80	132	14	11	147	5	5	12	5.5	M5 × 10	16	M5 × 8, Ø 5.5 × 20.5
100	158	16	13.1	175	5	5	12	6.6	M5 × 10	16	M6 × 10, Ø 6.6 × 25

Life Estimation (Elastic Bearing)

Life span for the elastic bearing

Operation cycle example

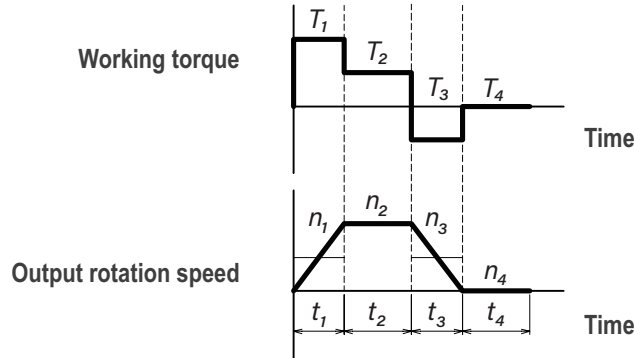

Calculation formula for output torque

Average output torque	Tao	Nm	$T_{ao} = \sqrt[3]{\frac{n_1 \cdot t_1 \cdot T_1 ^3 + n_2 \cdot t_2 \cdot T_2 ^3 + \dots + n_n \cdot t_n \cdot T_n ^3}{n_1 \cdot t_1 + n_2 \cdot t_2 + \dots + n_n \cdot t_n}}$
Peak output torque value	Tmo	Nm	$T_{mo} = \text{maximum value of } T_1, T_2, \dots, T_n$

Please make sure the peak output torque is below the maximum output torque in the specification table.

Calculation formula for input speed

Average output rotation speed	nao	r/min	$n_{ao} = \frac{n_1 \cdot t_1 + n_2 \cdot t_2 + \dots + n_n \cdot t_n}{t_1 + t_2 + \dots + t_n}$
Peak output rotation speed	nmo	r/min	$n_{mo} = \text{maximum value of } n_1, n_2, \dots, n_n$
Average input speed	nai	r/min	$n_{ai} = n_{ao} \times R \text{ (} R = \text{ratio)}$
Peak input speed value	nmi	r/min	$n_{mi} = n_{mo} \times R \text{ (} R = \text{ratio)}$

Please make sure the peak input speed value is below the maximum input speed in the specification table.

Calculation formula for life span

Part life span for the elastic bearing	Lhe	h	$L_{he} = 10000 \times \left(\frac{T_{ar}}{T_{ao}}\right)^3 \times \left(\frac{n_{ar}}{n_{ai}}\right)$
Rating torque	Tar	Nm	Nominal output torque in the specification table
Rating input rotation speed	nar	r/min	2000 r/min

Reducer Model/ Specifications	Dimensions	Life Estimation (Elastic Bearing)	Life Estimation (Main Bearing)	Maximum Load at Input Shaft	Lubricant Information	Attachment Fixture Requirement Info	Transmitting Torque	Input Section Structure/ Installation & Assembly	Motor Installation Procedure Info	Characteristics Data
-------------------------------	------------	-----------------------------------	--------------------------------	-----------------------------	-----------------------	-------------------------------------	---------------------	--	-----------------------------------	----------------------

Life Estimation (Main Bearing)

Main bearing specification (Cross roller bearing)

Series	Size	Pitch Circle Diameter of the Bearing Rollers	Offset	Basic Dynamic Load Rating	Basic Static Load Rating	Allowable Moment	Moment Rigidity
		Dm	L	C	Co	Mal	Km
		m	m	N	N	Nm	$\times 10^4$ Nm/rad
WPU-□-□-CR	35	0.0350	0.0095	4700	6070	41	4.38
	42	0.0425	0.0095	5290	7550	64	7.75
	50	0.0500	0.0095	5780	9000	91	12.8
	63	0.0620	0.0115	9600	15100	156	24.2
	80	0.0800	0.0130	15000	25000	313	53.9
WPS-□-□-SR	35	0.0500	0.0162	5800	8600	74	8.5
	42	0.0600	0.0184	10400	16300	124	15.4
	50	0.0700	0.0195	14600	22000	187	25.2
	63	0.0850	0.0241	21800	35800	258	39.2
	80	0.111	0.0299	38200	65400	580	100
WPU-□-□-SRH WPU-□-□-SRJ	35	0.0500	0.0217	5800	8600	74	8.5
	42	0.0600	0.0239	10400	16300	124	15.4
	50	0.0700	0.0255	14600	22000	187	25.2
	63	0.0850	0.0296	21800	35800	258	39.2
	80	0.111	0.0364	38200	65400	580	100

Life span for the main bearing

Operation cycle example

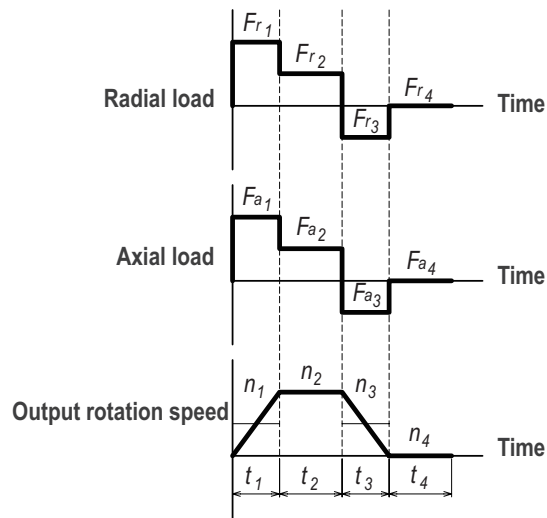

External load

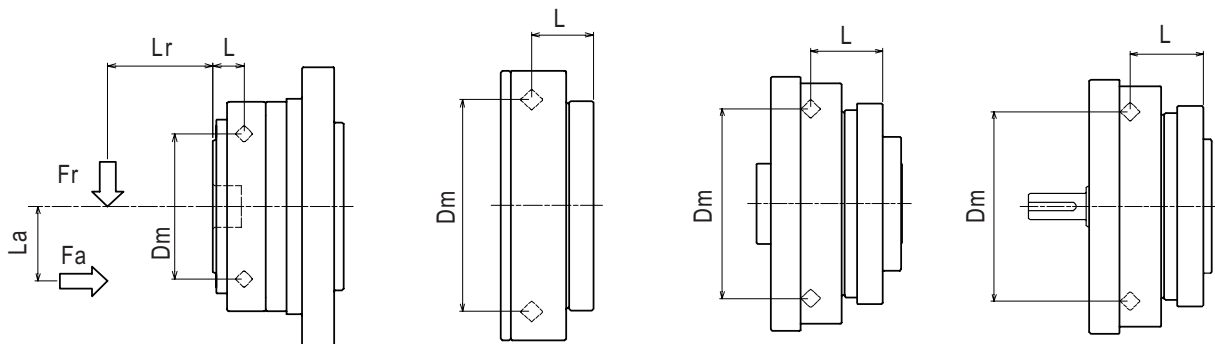

Life Estimation (Main Bearing)

Calculation formula for the largest working moment

Peak working moment	Mm	Nm	$Mm = Frm \cdot (Lr + L) + Fam \cdot La$
Peak radial load	Frm	N	$Frm = \text{maximum value of } Fr_1, Fr_2, \dots Fr_n$
Peak axial load	Fam	N	$Fam = \text{maximum value of } Fa_1, Fa_2, \dots Fa_n$

Please make sure the peak working moment is below the maximum allowable moment.

Calculation formula for the Average radial load, Axial load, Average output rotation speed, Average working moment

Average radial load	Fra	N	$Fra = \sqrt[10]{\frac{n_1 \cdot t_1 \cdot Fr_1 ^{10/3} + n_2 \cdot t_2 \cdot Fr_2 ^{10/3} + \dots + n_n \cdot t_n \cdot Fr_n ^{10/3}}{n_1 \cdot t_1 + n_2 \cdot t_2 + \dots + n_n \cdot t_n}}$
Axial load	Faa	N	$Faa = \sqrt[10]{\frac{n_1 \cdot t_1 \cdot Fa_1 ^{10/3} + n_2 \cdot t_2 \cdot Fa_2 ^{10/3} + \dots + n_n \cdot t_n \cdot Fa_n ^{10/3}}{n_1 \cdot t_1 + n_2 \cdot t_2 + \dots + n_n \cdot t_n}}$
Average output rotation speed	nao	r/min	$nao = \frac{n_1 \cdot t_1 + n_2 \cdot t_2 + \dots + n_n \cdot t_n}{t_1 + t_2 + \dots + t_n}$
Average working moment	Ma	Nm	$Ma = Fra \cdot (Lr + L) + Faa \cdot La$

Calculation formula for the Loading factor, Equivalent radial load

Loading factor	Xc, Yc	-	$\frac{Faa}{Fra + 2Ma / Dm} \leq 1.5$ in the case of, Xc = 1.0, Yc = 0.45
			$\frac{Faa}{Fra + 2Ma / Dm} > 1.5$ in the case of, Xc = 0.67, Yc = 0.67
Equivalent radial load	Pc	N	$Pc = Xc \cdot (Fra + 2Ma/Dm) + Yc \cdot Faa$

Life span for the main bearing

Life span for the main bearing	Lhc	h	$Lhc = \frac{10^6}{60 \cdot nao} \cdot \left(\frac{C}{fw \cdot Pc} \right)^{\frac{10}{3}}$
Impact factor	fw	-	1.0: no shock
			1.2: with some shock
			1.5: with shock and vibration

Reducer Model/
Specifications

Dimensions

Life Estimation
(Elastic Bearing)

Life Estimation
(Main Bearing)

Maximum Load
at Input Shaft

Lubricant Information

Attachment Fixture
Requirement Info

Transmitting Torque

Input Section Structure/
Installation & Assembly

Motor Installation
Procedure Info

Characteristics Data

Maximum Load at Input Shaft

Bearing specification (Open type, Unit)

Series	Size	A Bearing A		B Bearing B		a	b
		Basic Dynamic Load Rating	Basic Static Load Rating	Basic Dynamic Load Rating	Basic Static Load Rating		
		C	Co	C	Co		
		N	N	N	N		
		mm	mm			mm	mm
WPU-□-□-SRH	35	4000	2470	4000	2470	16.5	26.5
	42	4300	2950	4300	2950	17.5	29.5
	50	4500	3450	4500	3450	16	26
	63	4900	4350	4900	4350	17	29
	80	14100	10900	5350	5250	20	35.5
WPU-□-□-SRJ	35	2240	910	1080	430	24.5	21
	42	2700	1270	1610	710	27.5	23
	50	4350	2260	2240	910	32.3	25.2
	63	5600	2830	2700	1270	37.3	29.2
	80	9400	5000	4350	2260	39.4	38.1

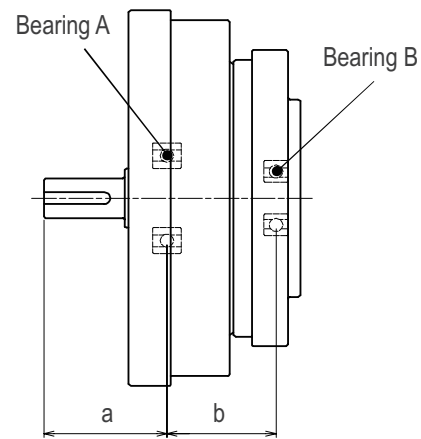
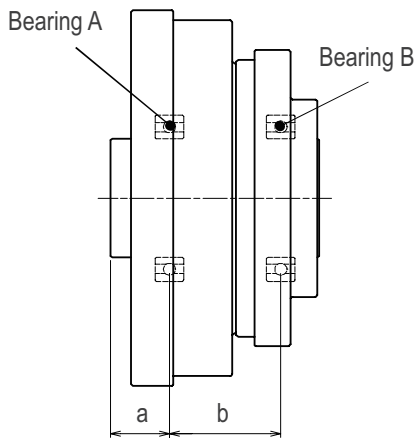

Maximum load (Average input rotation speed : 2000r/min, Life span : 10000h)

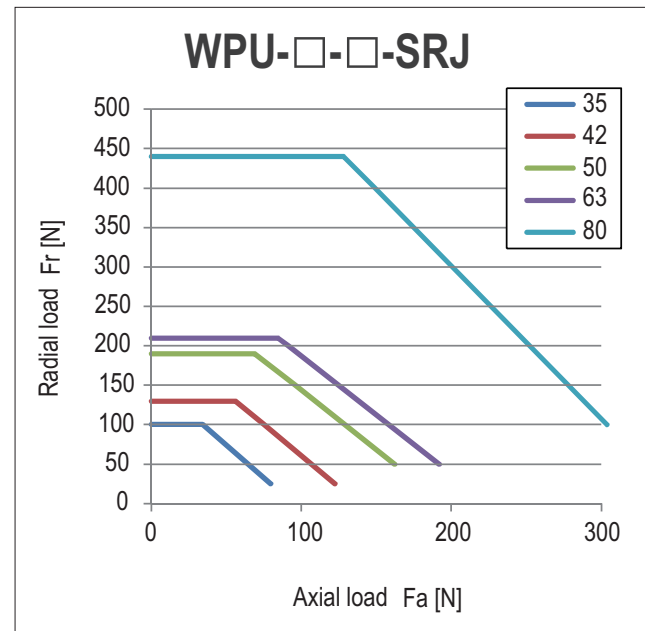
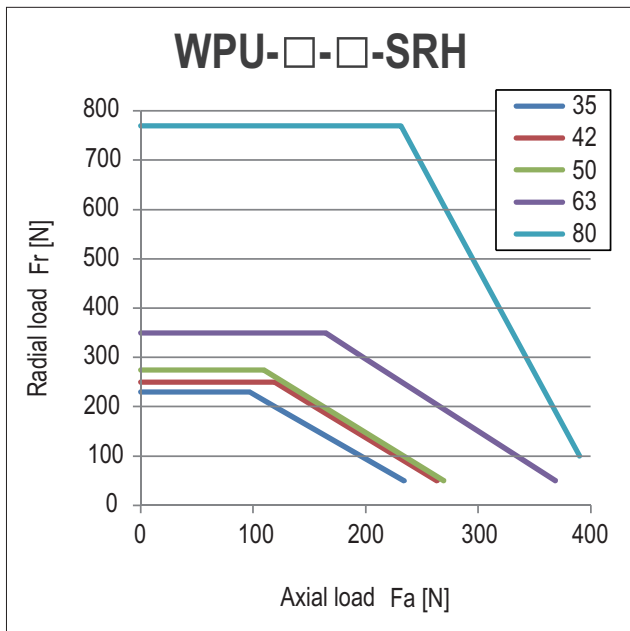

Lubricant Information

Grease

Sumiplex SFB No.1 (SUMICO LUBRICANT CO., LTD.)

Operating temperature range: 0~40°C (ambient temperature)

Grease application

- The quantity of grease applied to C should be adjusted depending on the mounting direction. C of the unit type product is already filled with the same quantity of grease as horizontal mounting.
- 50% of the space between input assy and casing inner wall should be filled with grease.
- If the amount of grease is not sufficient due to case design, please contact us.

Please apply grease according to the table below.

[grams]

Size	Applied part					
	A	B	C Horizontal	C Vertical Up	C Vertical Down	D
35	0.3	0.3	6	8	9	0.3
42	0.5	0.5	10	12	14	0.5
50	0.8	0.8	16	18	21	0.8
63	1.5	1.5	30	35	40	1.5
80	3.0	3.0	60	70	80	3.0

Grease application location

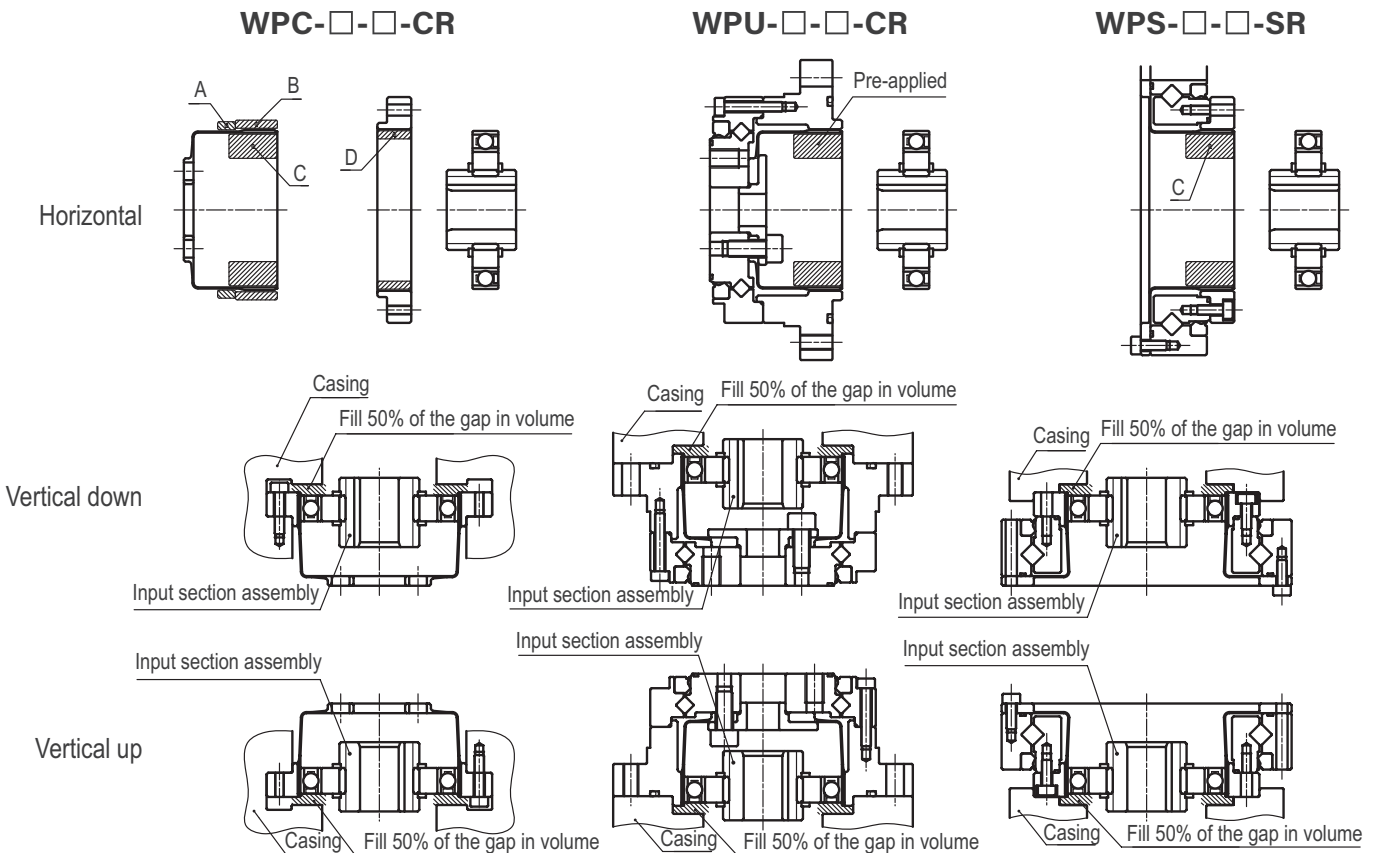

Reducer Model/ Specifications
Dimensions
Life Estimation (Elastic Bearing)
Life Estimation (Main Bearing)
Maximum Load at Input Shaft
Lubricant Information
Attachment Fixture Requirement Info
Transmitting Torque
Input Section Structure/ Installation & Assembly
Motor Installation Procedure Info
Characteristics Data

Attachment Fixture Requirement

WPC-□-□-CR

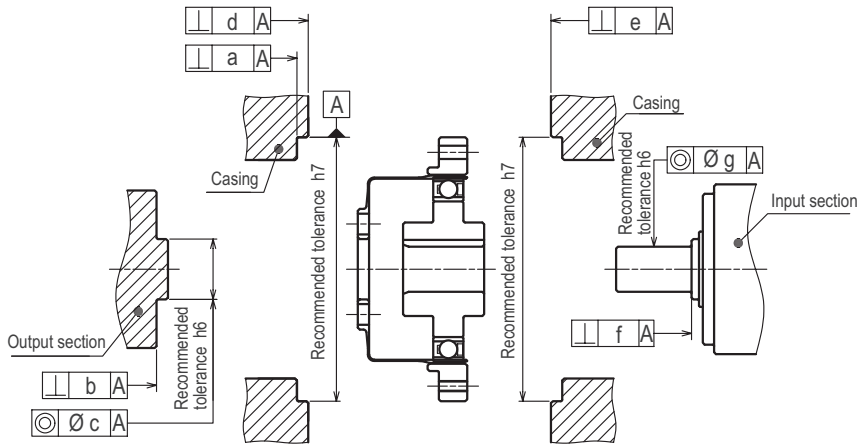

Installation accuracy

[mm]

Size	35	42	50	63	80
a	0.015	0.015	0.018	0.018	0.023
b	0.010	0.012	0.014	0.016	0.020
c	0.013	0.013	0.015	0.018	0.020
d	0.015	0.015	0.018	0.018	0.023
e	0.015	0.015	0.018	0.018	0.023
f	0.012	0.012	0.014	0.016	0.016
g	0.016	0.020	0.024	0.024	0.024

WPU-□-□-CR

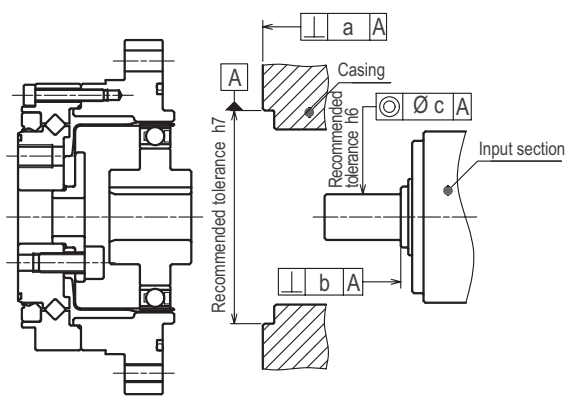

Installation accuracy

[mm]

Size	35	42	50	63	80
a	0.020	0.020	0.020	0.025	0.025
b	0.012	0.012	0.014	0.016	0.016
c	0.016	0.020	0.024	0.024	0.024

WPS-□-□-SR

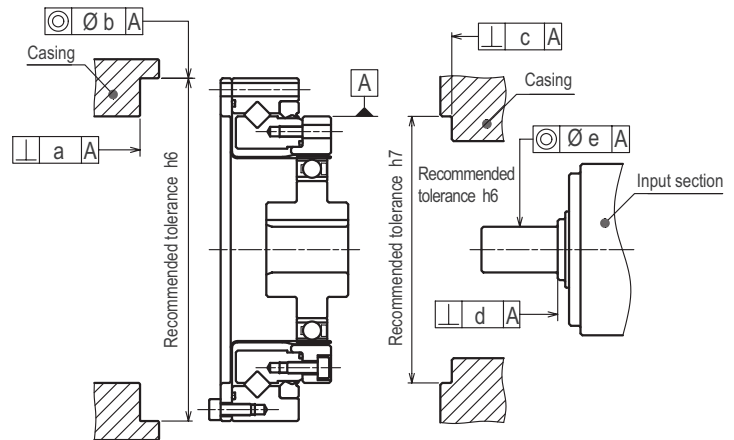

Installation accuracy

[mm]

Size	35	42	50	63	80
a	0.025	0.025	0.025	0.030	0.030
b	0.020	0.020	0.020	0.025	0.025
c	0.020	0.020	0.020	0.025	0.025
d	0.012	0.012	0.014	0.016	0.016
e	0.016	0.020	0.024	0.024	0.024

Transmitting Torque

Bolting

Refer to the table below for the bolt tightening torque.

Note that the transmittable torque varies depending on the bolt count (different between CF and CN) and tightening torque.

Tightening torque for bolts

Bolt Size	M3	M4	M5	M6	M8	M10
Tightening Torque [Nm]	1.9	4.3	8.7	15	36	71

Recommended bolt: Strength rating 12.9

Bolt specifications and transmitting torque (Closed Type, Unit)

Output flange attachment

Size	35	42	50	63	80
Bolt Size	M4	M5	M6	M8	M10
Bolt Count	6	6	8	8	8
Bolt PCD (mm)	23	27	32	42	55
Tightening Torque [Nm]	4.3	8.7	15	36	71
Transmitting Torque [Nm]	56	106	238	566	1177

Internal gear attachment (CR)

Size	35	42	50	63	80
Bolt Size	M4	M4	M5	M5	M6
Bolt Count	8	8	8	10	12
Bolt PCD [mm]	65	71	82	96	125
Tightening Torque [Nm]	4.3	4.3	8.7	8.7	15
Transmitting Torque [Nm]	210	230	430	629	1392

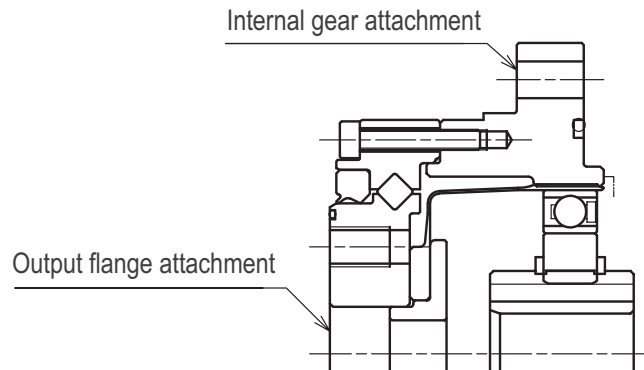

Reducer Model/
Specifications

Dimensions

Life Estimation
(Elastic Bearing)

Life Estimation
(Main Bearing)

Maximum Load
at Input Shaft

Lubricant Information

Attachment Fixture
Requirement Info

Transmitting Torque

Input Section Structure/
Installation & Assembly

Motor Installation
Procedure Info

Characteristics Data

Transmitting Torque

Bolt specifications and transmitting torque (Closed type, Component)

Flex Gear Attachment

Size	35	42	50	63	80
Bolt Size	M4	M5	M5	M6	M8
Bolt Count	6	6	8	8	8
Bolt PCD [mm]	17	19	24	30	40
Tightening Torque [Nm]	4.3	8.7	8.7	15	36
Transmitting Torque [Nm]	41	75	126	223	539

Internal gear attachment (CR)

Size	35	42	50	63	80
Bolt Size	M3	M3	M3	M4	M5
Bolt Count	8	16	16	16	16
Bolt PCD [mm]	44	54	62	75	100
Tightening Torque [Nm]	1.9	1.9	1.9	4.3	8.7
Transmitting Torque [Nm]	82	200	230	485	1048

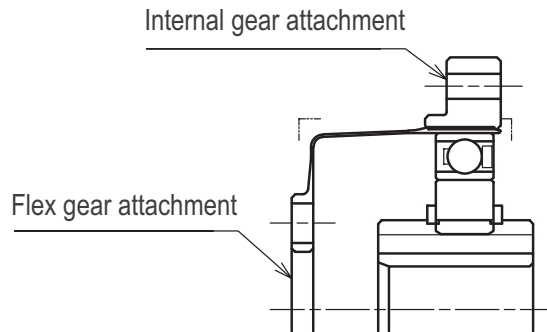

Reinforcement

Pins can be added if the transmittable torque at the flex gear interface is not sufficient. As an option, holes can be added.

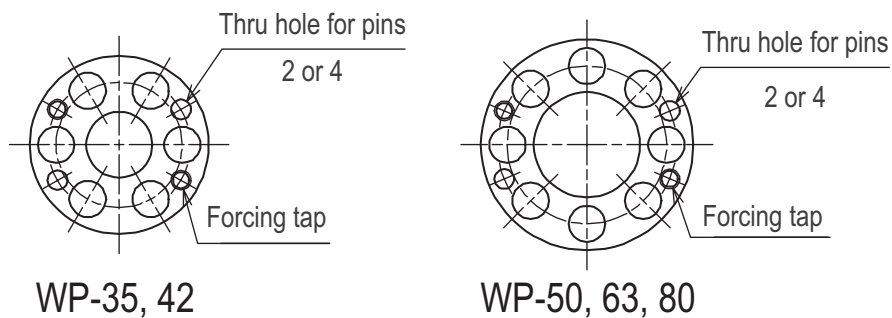

WP-35, 42

WP-50, 63, 80

Transmitting Torque

Bolt specifications and transmitting torque (Open type)

Flex Gear Attachment

Size	35	42	50	63	80
Bolt Size	M3	M3	M3	M4	M5
Bolt Count	8	12	12	12	12
Bolt PCD [mm]	64	74	84	102	132
Tightening Torque [Nm]	1.9	1.9	1.9	4.3	8.7
Transmitting Torque [Nm]	119	206	234	495	1037

Internal gear attachment

Size	35	42	50	63	80
Bolt Size	M3	M3	M3	M4	M5
Bolt Count	8	16	16	16	16
Bolt PCD [mm]	44	54	62	77	100
Tightening Torque [Nm]	1.9	1.9	1.9	4.3	8.7
Transmitting Torque [Nm]	82	200	230	498	1048

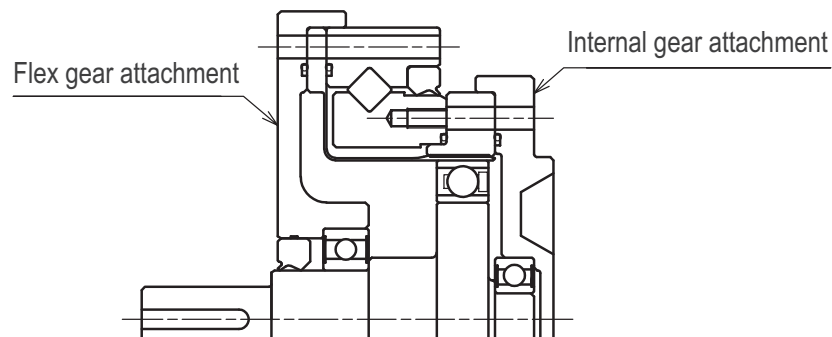
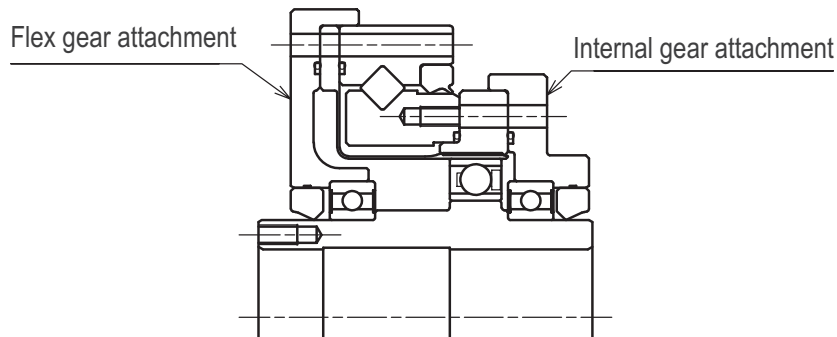
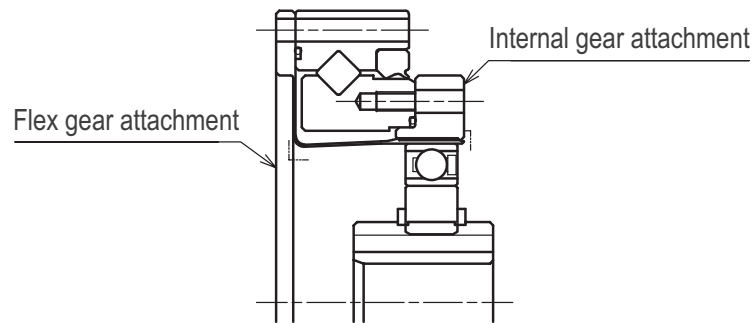

Reducer Model/
Specifications

Dimensions

Life Estimation
(Elastic Bearing)

Life Estimation
(Main Bearing)

Maximum Load
at Input Shaft

Lubricant Information

Attachment Fixture
Requirement Info

Transmitting Torque

Input Section Structure/
Installation & Assembly

Motor Installation
Procedure Info

Characteristics Data

Input Section Structure

There are two types of input section structure, spline type (self-centering feature) and rigid type.

Oldham type (Self-centering)

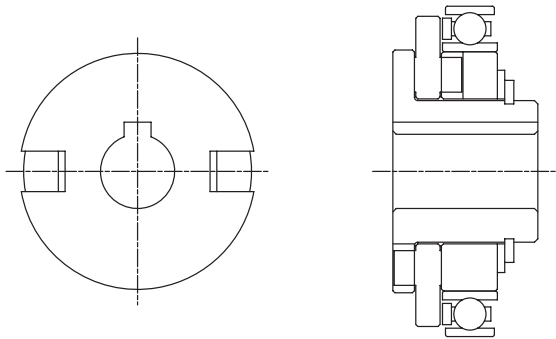

Rigid type

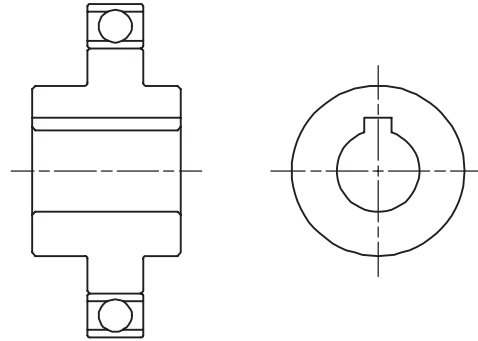

Cam hole diameter

The diameter of the cam opening is customizable. Holes smaller than the 'standard hole size' in the table will be built in the spline type. Holes equal to or larger than the 'standard hole size' and smaller than the 'maximum hole size' will be built in the rigid type. Please contact us if you need sizes outside the specification in the table.

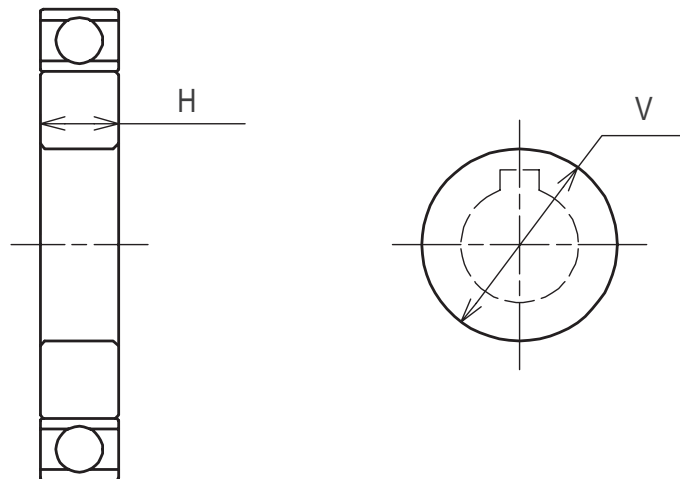

Cam dimension

[mm]

Size	35	42	50	63	80
Standard Bore Size	6	8	12	14	14
V Maximum Bore Size	17	20	23	28	36
V Minimum Thickness	6	7	8	9	11

Installation and Assembly Instructions

WPC-□-□-CR

Shaft installation instruction

Please design the support structure for input shaft and output shaft so that both radial and axial loads are supported. (Diagram below shows an example)

Inside thrust load has an effect on the cam. Secure cam from possible axial movement.

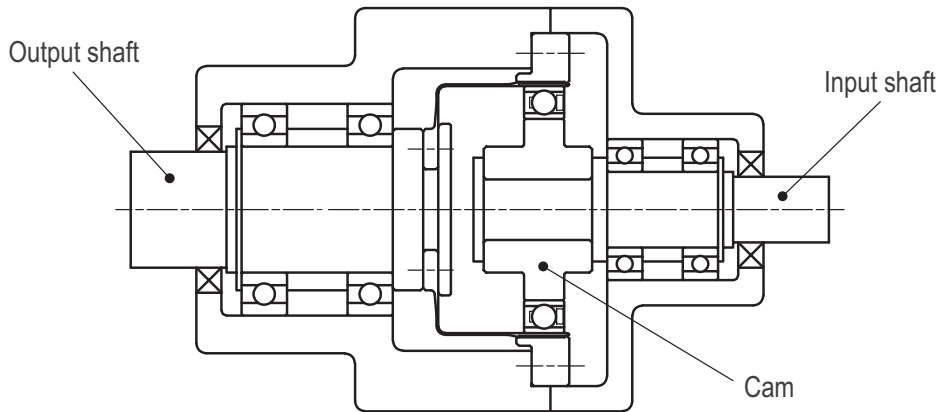

WPC-□-□-CR

Attachment flange requirement

For an attachment flange that comes in contact with flex gear, please build the corner radius according to the table below, in order to prevent damage.

Item	35	42	50	63	80
D	24.5	29	34	42	55
R	1.2	1.2	1.4	1.5	2
t	2	2.5	2.5	5	7

[mm]

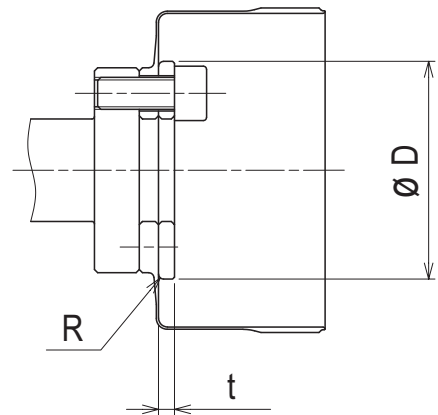

Warm-up run

After assembly, "Warm-up run" is necessary before run with load / torque. The purpose is to coat the Flex gear and Internal gear surface evenly with enough grease in order to meet the load / torque performance.

Condition example

- Load - No load
- Input rotation speed - Start slowly from 1,000r/min or less, then accelerate up to 3,000r/min
- Test time - About 1 hour
- Output rotation angle - As large as possible

Reducer Model/
Specifications

Dimensions

Life Estimation
(Elastic Bearing)

Life Estimation
(Main Bearing)

Maximum Load
at Input Shaft

Lubricant Information

Attachment Fixture
Requirement Info

Transmitting Torque

Input Section Structure/
Installation & Assembly

Motor Installation
Procedure Info

Characteristics Data

Motor Installation Procedure

WPU-□-□-C□

Procedure 1

- Attach the flange on to the motor
- Attach the input section assembly with elastic bearings to the motor shaft
- Attach the unit

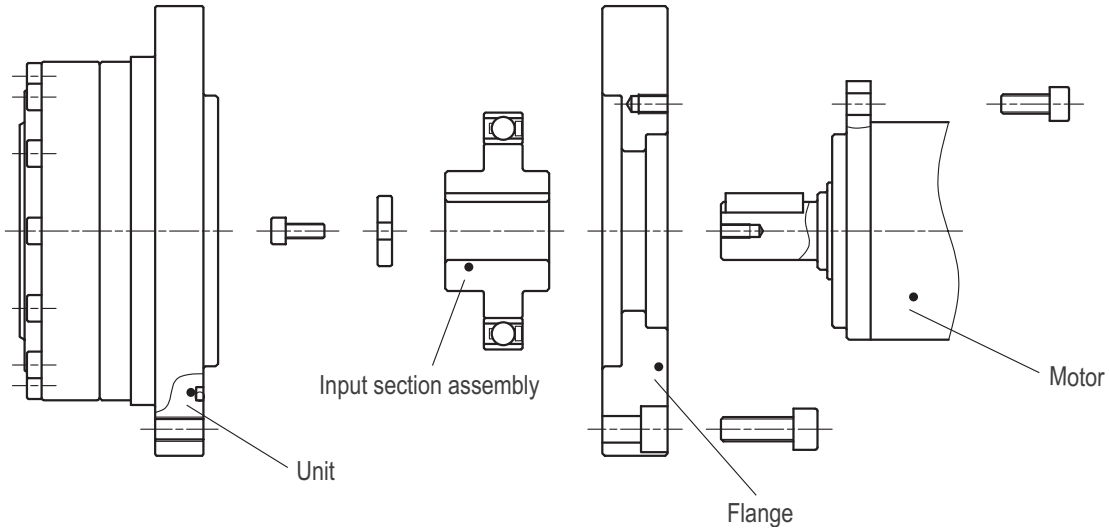

* This model is not directly attached to a motor. Necessary fixtures are to be prepared at the customer side.

Procedure 2

- Attach the input section assembly with elastic bearings to the motor shaft
- Attach the flange on to the motor
- Attach the unit

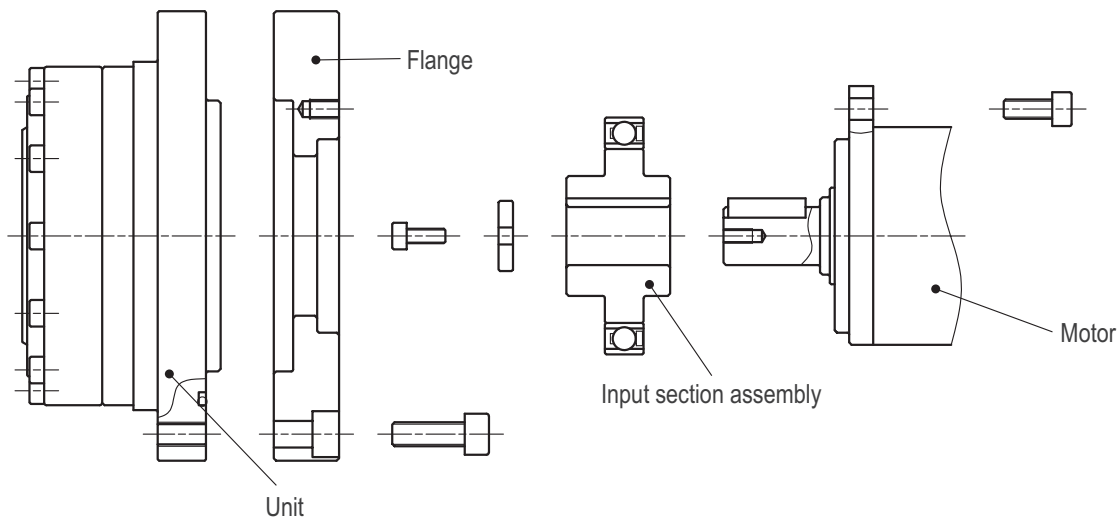

* This model is not directly attached to a motor. Necessary fixtures are to be prepared at the customer side.



Caution During Installation

- Do not use excessive force while mating parts
- Please watch for tilting during input section assembly and motor

Characteristics Data

Closed type

Ratcheting torque

[Nm]

Ratio	Size				
	35	42	50	63	80
50	120	220	340	650	1400
80	140	250	410	700	1600
100	130	210	340	690	1300
120	-	200	310	680	1200
160	-	-	300	620	1000

Buckling torque

[Nm]

Ratio	Size				
	35	42	50	63	80
50 ~ 160	260	500	800	1700	3500

Open type

Ratcheting torque

[Nm]

Ratio	Size				
	35	42	50	63	80
50	120	220	340	650	1400
80	140	250	410	700	1600
100	130	210	340	690	1300
120	-	200	310	680	1200
160	-	-	300	620	1000

Buckling torque

[Nm]

Ratio	Size				
	35	42	50	63	80
50 ~ 160	180	350	590	1100	2400

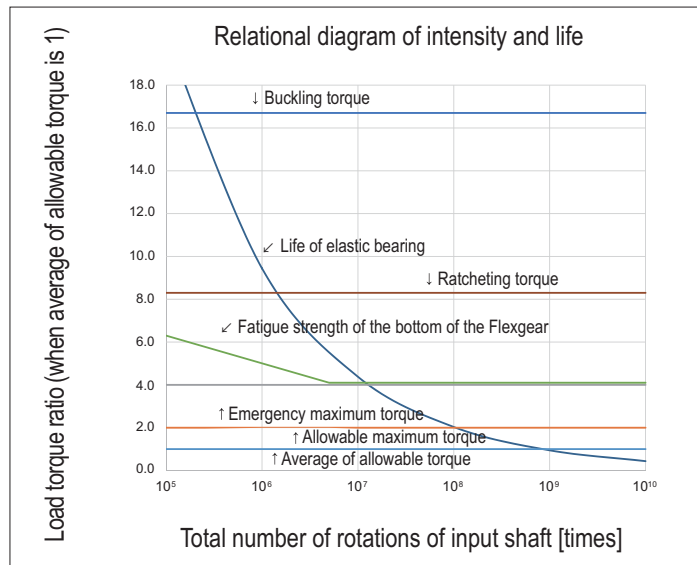

* The graph is based on actual measurement value. For reference only.

Characteristics Data

Transmission angular accuracy

What is Transmission Angular Accuracy?

It is the difference between the measured output rotation angle and the theoretical angle, while input shaft is rotated with no load.

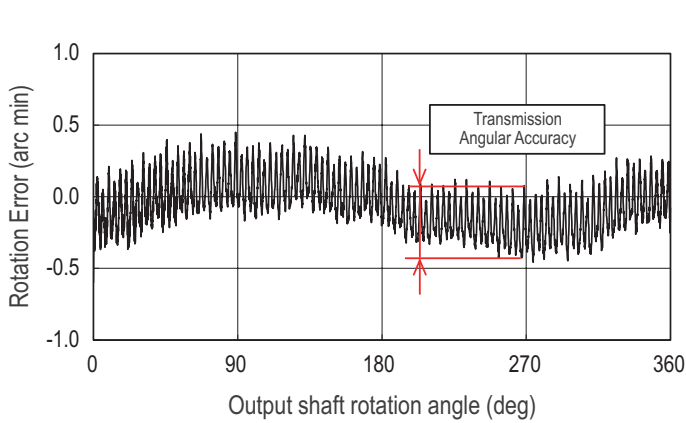

[arc min]

Ratio	Size				
	35	42	50	63	80
50	1.5	1.5	1.0	1.0	1.0
80	1.5	1.5	1.0	1.0	1.0
100	1.5	1.5	1.0	1.0	1.0
120	-	1.5	1.0	1.0	1.0
160	-	-	1.0	1.0	1.0

Table values are reference values.

Hysteresis loss

What is Hysteresis Loss?

When torque load is applied at the output shaft in alternate direction repeatedly with input shaft fixed, there is residual twisting angle when torque is back to zero.

In this context, hysteresis loss is the difference in the forward and backward twisting angle

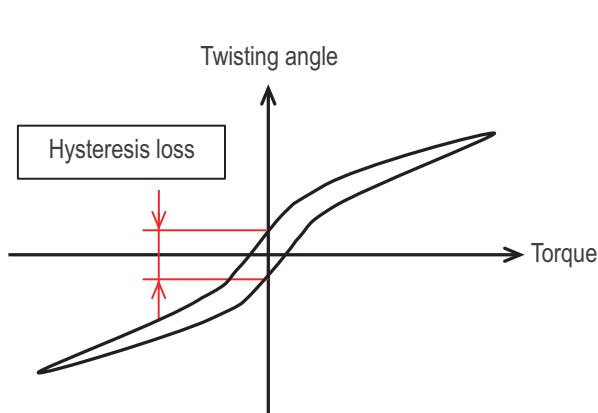

[arc min]

Ratio	Size				
	35	42	50	63	80
50	2.0	2.0	2.0	2.0	2.0
80	1.0	1.0	1.0	1.0	1.0
100	1.0	1.0	1.0	1.0	1.0
120	-	1.0	1.0	1.0	1.0
160	-	-	1.0	1.0	1.0

Table values are reference values.

Characteristics Data

Maximum backlash

What is Maximum Backlash?

In this context, maximum backlash is the output backlash for oldham type input shaft.

(Backlash is zero for rigid type input, because gear engagement backlash is zero.)

[arc min]

Ratio	Size				
	35	42	50	63	80
50	35	29	25	20	16
80	22	18	16	12	10
100	18	15	13	10	8
120	-	12	10	8	6
160	-	-	8	6	5

Stiffness (Closed type, Unit)

What is Stiffness?

In this context, stiffness is the output shaft twisting angle and the spring coefficient, while torque load is applied to the output shaft with input side fixed.

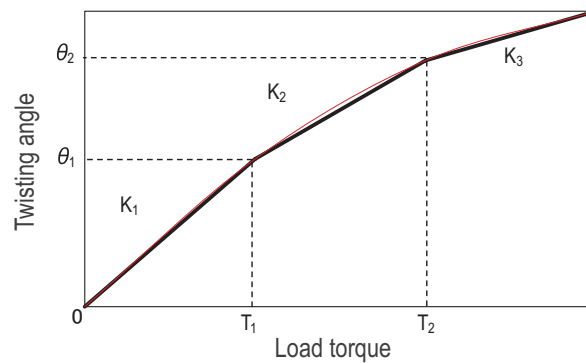

K1... Spring coefficient at 0 ~ T₁ torque
 K2... Spring coefficient at T₁ ~ T₂ torque
 K3... Spring coefficient at T₂ ~ torque

Ratio	Item	Unit	Size				
			35	42	50	63	80
-	T ₁	Nm	2	3.9	7	14	29
-	T ₂	Nm	6.9	12	25	48	108
50	K ₁	× 10 ⁴ Nm/rad	0.41	0.87	1.3	2.5	5.5
	K ₂	× 10 ⁴ Nm/rad	0.57	1.1	1.8	3.4	7.9
	K ₃	× 10 ⁴ Nm/rad	0.70	1.4	2.4	4.5	10
	θ ₁	arcmin	1.7	1.5	1.9	1.9	1.8
	θ ₂	arcmin	4.6	4.1	5.3	5.4	5.3
80 100 120 160	K ₁	× 10 ⁴ Nm/rad	0.51	0.90	1.3	2.8	5.8
	K ₂	× 10 ⁴ Nm/rad	0.67	1.3	2.1	4.5	9.6
	K ₃	× 10 ⁴ Nm/rad	0.78	1.5	2.5	5.2	10.5
	θ ₁	arcmin	1.3	1.5	1.9	1.7	1.7
	θ ₂	arcmin	3.9	3.6	4.8	4.3	4.5

Average value shown in the table.

Reducer Model/ Specifications	Dimensions	Life Estimation (Elastic Bearing)	Life Estimation (Main Bearing)	Maximum Load at Input Shaft	Lubricant Information	Attachment Fixture Requirement Info	Transmitting Torque	Input Section Structure/ Installation & Assembly	Motor Installation Procedure Info	Characteristics Data
-------------------------------	------------	-----------------------------------	--------------------------------	-----------------------------	-----------------------	-------------------------------------	---------------------	--	-----------------------------------	----------------------

Characteristics Data

Starting torque

What is Starting Torque?

Input torque needed for input side to start rotating (no load, ambient temperature: 25°C).

Closed type, Unit

Open type, Simple unit

[cNm]

Ratio	Size				
	35	42	50	63	80
50	2.1	3.9	7.7	17	22
80	2.0	3.4	6.6	14	21
100	1.9	3.0	6.2	12	20
120	-	2.7	5.8	11	17
160	-	-	5.3	10	16

*1 For reference only. Torque value may vary depending on the condition.

*2 Charts does not show effects due to rotation resistance of bearings and oil seals on the input side.

Open type, Unit (Hollow shaft)

[cNm]

Ratio	Size				
	35	42	50	63	80
50	5.6	8.1	10.2	20.1	26.0
80	5.5	7.6	9.1	17.0	25.0
100	5.4	7.2	8.7	15.2	24.0
120	-	6.9	8.3	14.2	21.0
160	-	-	7.8	13.2	20.0

*1 For reference only. Torque value may vary depending on the condition.

*2 Charts does not show effects due to rotation resistance of bearings and oil seals on the input side.

Open type, Unit (Input shaft)

[cNm]

Ratio	Size				
	35	42	50	63	80
50	5.0	7.3	9.2	18.1	23.4
80	5.0	6.8	8.2	15.3	22.5
100	4.9	6.5	7.8	13.6	21.6
120	-	6.2	7.5	12.7	18.9
160	-	-	7.0	11.8	18.0

*1 For reference only. Torque value may vary depending on the condition.

*2 Charts does not show effects due to rotation resistance of bearings and oil seals on the input side.

Characteristics Data

Output starting torque

What is Output Starting Torque?

Output torque needed for output side to start rotating (no load, ambient temperature: 25°C).

Closed type, Unit

Open type, Simple unit

[Nm]

Ratio	Size				
	35	42	50	63	80
50	1.5	2.2	3.3	8.4	16
80	1.6	2.7	3.5	10	21
100	1.8	3.2	4.2	12	24
120	-	3.4	5.6	14	27
160	-	-	6.6	20	38

*1 For reference only. Torque value may vary depending on the condition.

*2 Charts does not show effects due to rotation resistance of bearings and oil seals on the input side.

Open type, Unit (Hollow shaft)

[cNm]

Ratio	Size				
	35	42	50	63	80
50	3.3	4.3	5.8	11.6	18.0
80	3.8	5.6	7.0	16.0	28.9
100	4.6	7.2	9.2	22.4	40.4
120	-	8.6	13.3	30.0	53.8
160	-	-	19.4	54.4	99.3

*1 For reference only. Torque value may vary depending on the condition.

*2 Charts does not show effects due to rotation resistance of bearings and oil seals on the input side.

Open type, Unit (Input shaft)

[cNm]

Ratio	Size				
	35	42	50	63	80
50	2.9	3.9	5.2	10.4	16.2
80	3.4	5.0	6.3	14.4	26.0
100	4.2	6.5	8.3	20.1	36.4
120	-	7.8	11.9	27.0	48.5
160	-	-	17.5	48.9	89.4

*1 For reference only. Torque value may vary depending on the condition.

*2 Charts does not show effects due to rotation resistance of bearings and oil seals on the input side.

Reducer Model/
Specifications

Dimensions

Life Estimation
(Elastic Bearing)

Life Estimation
(Main Bearing)

Maximum Load
at Input Shaft

Lubricant Information

Attachment Fixture
Requirement Info

Transmitting Torque

Input Section Structure/
Installation & Assembly

Motor Installation
Procedure Info

Characteristics Data

Characteristics Data

No-load running torque (Closed type, Unit) (Open type, Simple unit)

What is No-load Running Torque?

Input torque needed to keep it running with no load (average value, ambient temperature: 25°C).

[cNm]

Ratio	Input Rotation Speed	Size				
		35	42	50	63	80
50	500r/min	3.8	6.4	10	18	38
	1000r/min	4.9	7.7	12	22	54
	2000r/min	5.9	8.2	14	24	57
	3500r/min	6.3	8.7	15	26	63
80	500r/min	3.0	5.8	8.4	21	34
	1000r/min	3.7	7.4	10	24	41
	2000r/min	4.6	8.0	12	25	47
	3500r/min	5.1	8.8	12	26	53
100	500r/min	2.8	5.5	7.3	16	35
	1000r/min	3.6	7.3	9.2	19	44
	2000r/min	4.3	7.9	12	22	54
	3500r/min	4.6	8.8	13	23	57
120	500r/min	-	5.0	5.9	14	34
	1000r/min	-	5.7	8.1	18	41
	2000r/min	-	6.5	9.7	20	43
	3500r/min	-	7.2	11	21	45
160	500r/min	-	-	7.2	15	25
	1000r/min	-	-	8.9	19	30
	2000r/min	-	-	11	22	37
	3500r/min	-	-	11	22	40

*1 For reference only. Torque value may vary depending on the condition.

*2 Charts does not show effects due to rotation resistance of bearings and oil seals on the input side.

Characteristics Data

No-load running torque (Open type, Unit (Hollow shaft))

What is No-load Running Torque?

Input torque needed to keep it running with no load (average value, ambient temperature: 25°C).

[cNm]

Ratio	Input Rotation Speed	Size				
		35	42	50	63	80
50	500r/min	11.0	16.5	22.4	34.1	40.5
	1000r/min	11.9	19.2	26.1	39.5	45.0
	2000r/min	13.0	21.7	28.9	44.4	49.7
	3500r/min	15.0	21.7	33.0	51.5	58.8
80	500r/min	10.3	13.5	22.9	34.7	51.5
	1000r/min	11.7	14.9	23.4	38.2	60.0
	2000r/min	12.4	17.0	25.6	41.7	63.0
	3500r/min	12.7	19.3	29.6	44.4	67.5
100	500r/min	10.3	15.8	20.9	37.3	53.5
	1000r/min	11.6	17.3	24.2	41.5	55.0
	2000r/min	13.1	20.2	25.8	49.4	60.0
	3500r/min	13.7	21.0	27.5	54.8	68.5
120	500r/min	-	12.8	23.5	34.6	38.0
	1000r/min	-	13.3	26.3	39.0	42.3
	2000r/min	-	15.2	30.4	47.5	46.7
	3500r/min	-	18.7	34.7	51.7	51.9
160	500r/min	-	-	21.5	28.5	47.5
	1000r/min	-	-	23.3	30.0	53.5
	2000r/min	-	-	27.0	32.6	56.4
	3500r/min	-	-	29.1	35.4	63.7

*1 For reference only. Torque value may vary depending on the condition.

*2 Charts does not show effects due to rotation resistance of bearings and oil seals on the input side.

Reducer Model/ Specifications	Dimensions	Life Estimation (Elastic Bearing)	Life Estimation (Main Bearing)	Maximum Load at Input Shaft	Lubricant Information	Attachment Fixture Requirement Info	Transmitting Torque	Input Section Structure/ Installation & Assembly	Motor Installation Procedure Info	Characteristics Data
-------------------------------	------------	-----------------------------------	--------------------------------	-----------------------------	-----------------------	-------------------------------------	---------------------	--	-----------------------------------	----------------------

Characteristics Data

No-load running torque (Open type, Unit (Input shaft))

What is No-load Running Torque?

Input torque needed to keep it running with no load (average value, ambient temperature: 25°C).

Ratio	Input Rotation Speed	Size				
		35	42	50	63	80
50	500r/min	4.4	8.1	12.2	17.7	26.3
	1000r/min	5.3	8.8	13.8	19.4	28.0
	2000r/min	6.2	9.2	15.2	23.8	30.0
	3500r/min	6.5	9.8	17.0	25.8	30.5
80	500r/min	4.8	7.6	13.6	23.1	30.4
	1000r/min	5.6	8.3	15.1	23.1	32.0
	2000r/min	6.0	9.2	16.2	25.4	36.0
	3500r/min	5.7	9.6	17.1	25.7	39.0
100	500r/min	5.1	8.8	13.4	22.2	30.0
	1000r/min	5.7	9.8	14.3	23.1	31.7
	2000r/min	5.6	10.5	16.3	24.7	36.5
	3500r/min	5.7	11.2	16.4	29.6	38.0
120	500r/min	-	7.4	11.7	15.7	31.7
	1000r/min	-	8.6	13.9	16.7	35.0
	2000r/min	-	10.5	15.9	17.6	38.5
	3500r/min	-	11.0	18.1	19.3	40.0
160	500r/min	-	-	9.8	14.1	20.0
	1000r/min	-	-	11.9	15.8	22.7
	2000r/min	-	-	13.4	16.9	26.0
	3500r/min	-	-	15.1	18.6	27.5

*1 For reference only. Torque value may vary depending on the condition.

*2 Charts does not show effects due to rotation resistance of bearings and oil seals on the input side.

Characteristics Data

Efficiency (Closed type, Unit) (Open type, Simple unit)

- Percentile load (%) is equal to load torque divided by allowable average torque.
- Ambient temperature: 25°C

WPU-35-50

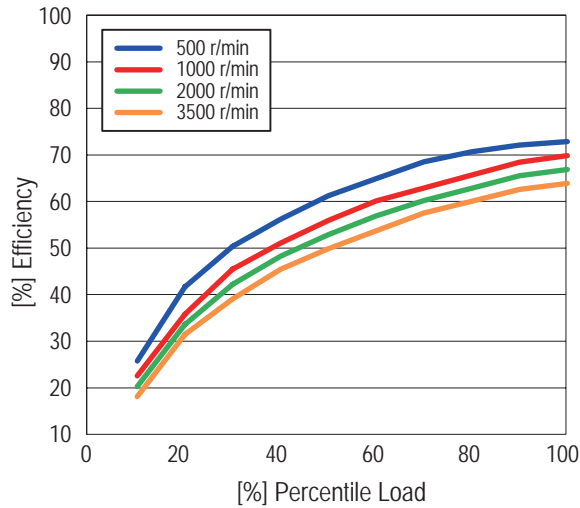

WPU-35-80

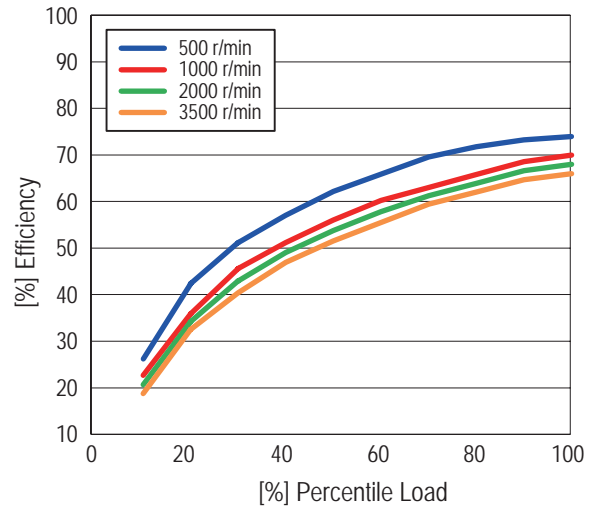

WPU-35-100

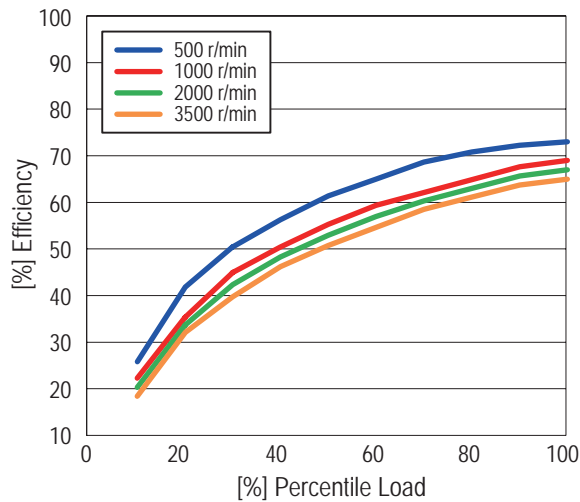

*1 These diagrams represent the average value of the actual measurement.
 *2 Charts does not show effects due to rotation resistance of bearings and oil seals on the input side.

Reducer Model/ Specifications	Dimensions	Life Estimation (Elastic Bearing)	Life Estimation (Main Bearing)	Maximum Load at Input Shaft	Lubricant Information	Attachment Fixture Requirement Info	Transmitting Torque	Input Section Structure/ Installation & Assembly	Motor Installation Procedure Info	Characteristics Data
-------------------------------	------------	-----------------------------------	--------------------------------	-----------------------------	-----------------------	-------------------------------------	---------------------	--	-----------------------------------	----------------------

Characteristics Data

Efficiency (Closed type, Unit) (Open type, Simple unit)

- Percentile load (%) is equal to load torque divided by allowable average torque.
- Ambient temperature: 25°C

WPU-42-50

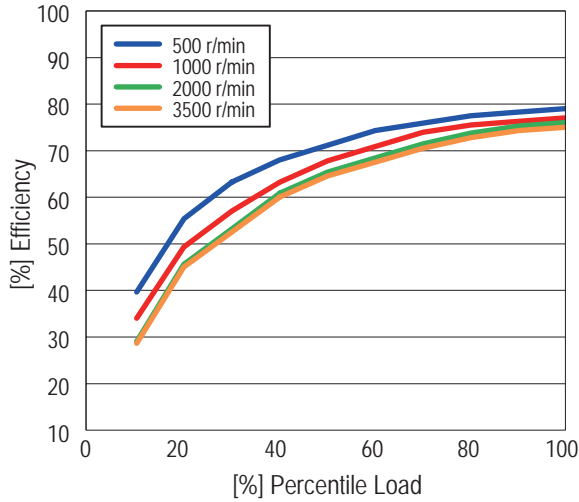

WPU-42-80

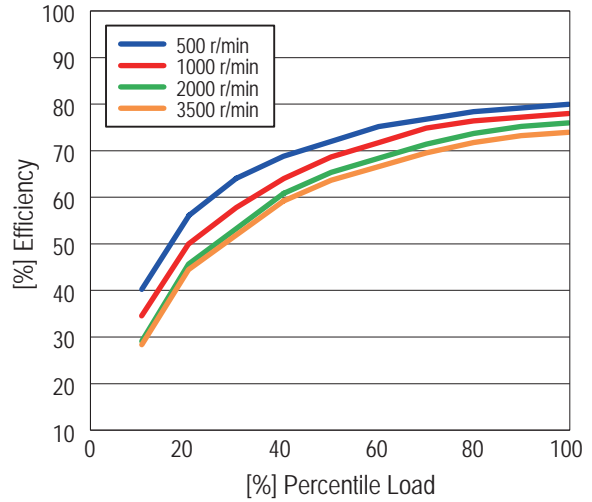

WPU-42-100

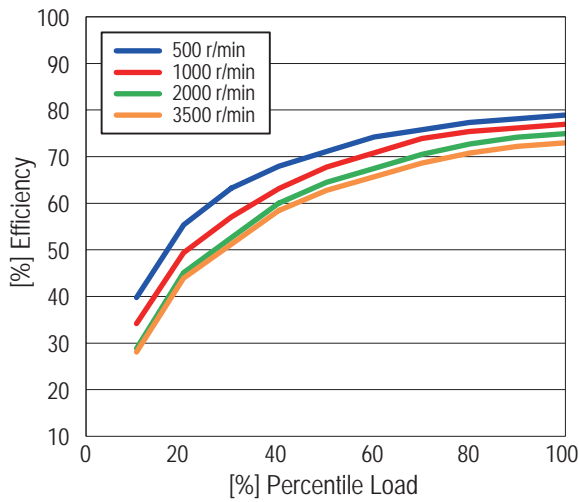

WPU-42-120

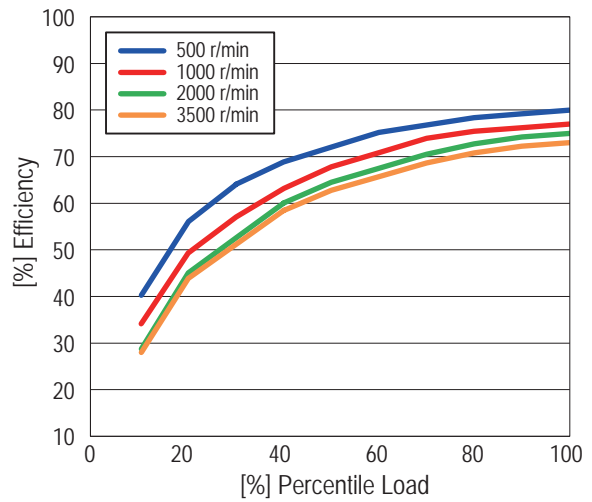

*1 These diagrams represent the average value of the actual measurement.

*2 Charts does not show effects due to rotation resistance of bearings and oil seals on the input side.

Characteristics Data

Efficiency (Closed type, Unit) (Open type, Simple unit)

- Percentile load (%) is equal to load torque divided by allowable average torque.
- Ambient temperature: 25°C

WPU-50-50

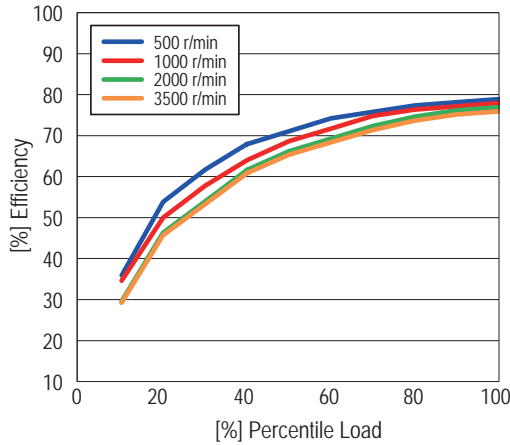

WPU-50-80

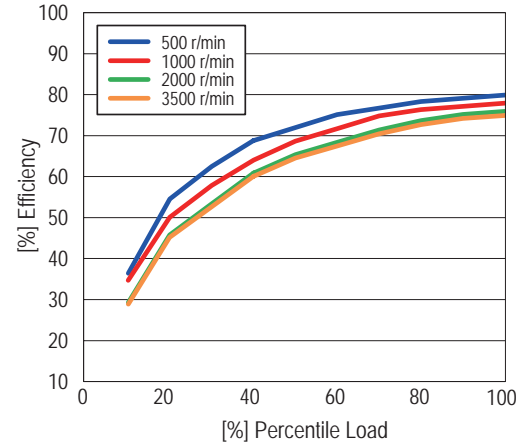

WPU-50-100

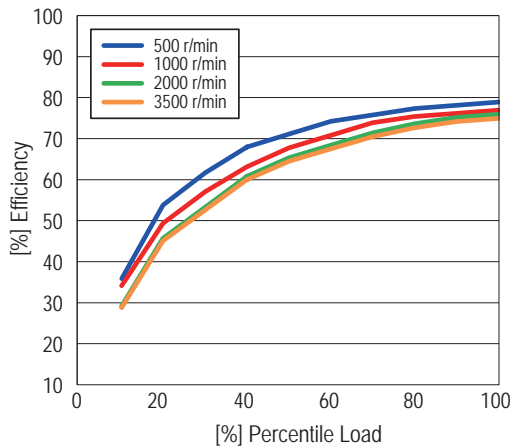

WPU-50-120

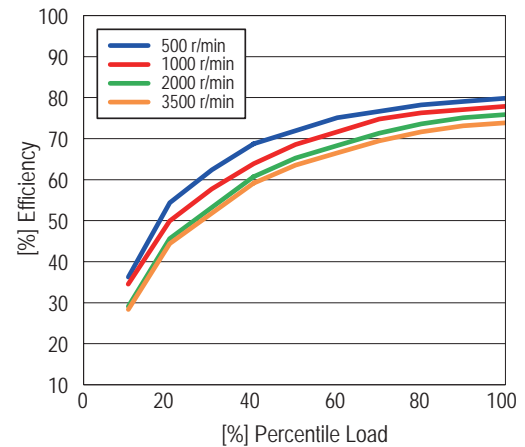

WPU-50-160

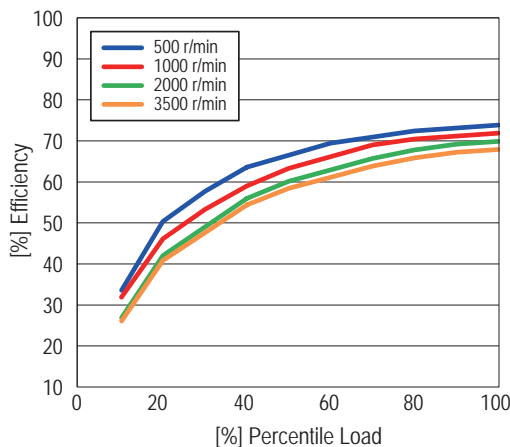

*1 These diagrams represent the average value of the actual measurement.

*2 Charts does not show effects due to rotation resistance of bearings and oil seals on the input side.

Reducer Model/ Specifications
Dimensions
Life Estimation (Elastic Bearing)
Life Estimation (Main Bearing)
Maximum Load at Input Shaft
Lubricant Information
Attachment Fixture Requirement Info
Transmitting Torque
Input Section Structure/ Installation & Assembly
Motor Installation Procedure Info
Characteristics Data

Characteristics Data

Efficiency (Closed type, Unit) (Open type, Simple unit)

- Percentile load (%) is equal to load torque divided by allowable average torque.
- Ambient temperature: 25°C

WPU-63-50

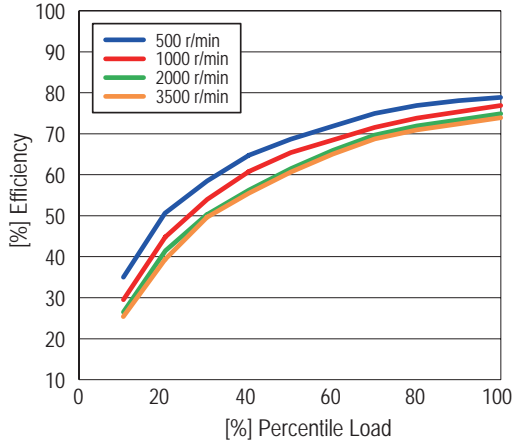

WPU-63-80

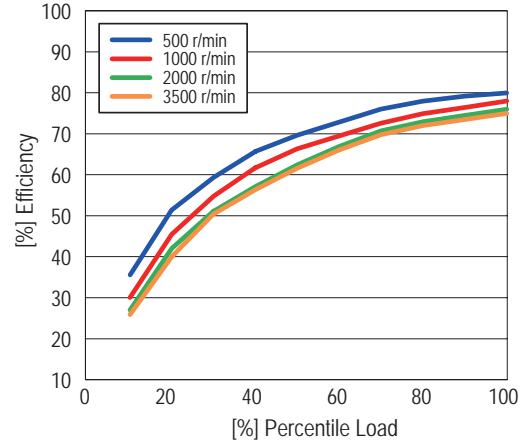

WPU-63-100

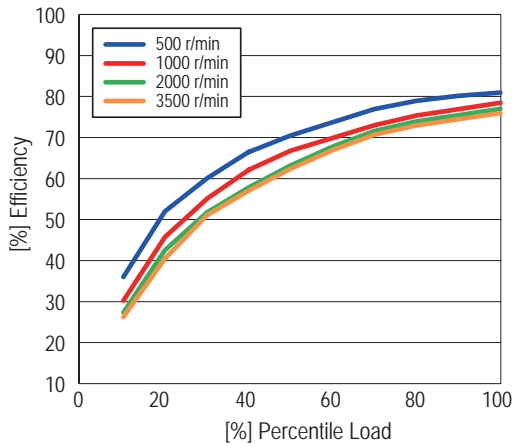

WPU-63-120

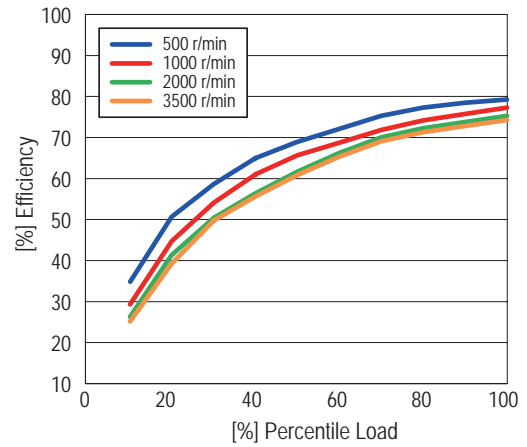

WPU-63-160

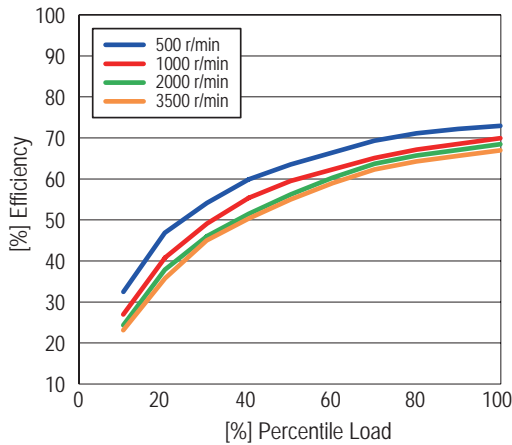

*1 These diagrams represent the average value of the actual measurement.

*2 Charts does not show effects due to rotation resistance of bearings and oil seals on the input side.

Characteristics Data

Efficiency (Closed type, Unit) (Open type, Simple unit)

- Percentile load (%) is equal to load torque divided by allowable average torque.
- Ambient temperature: 25°C

WPU-80-50

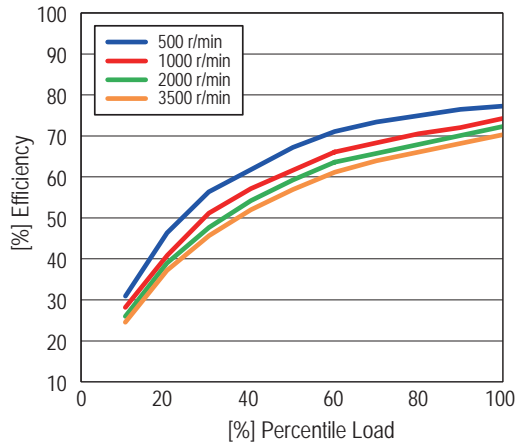

WPU-80-80

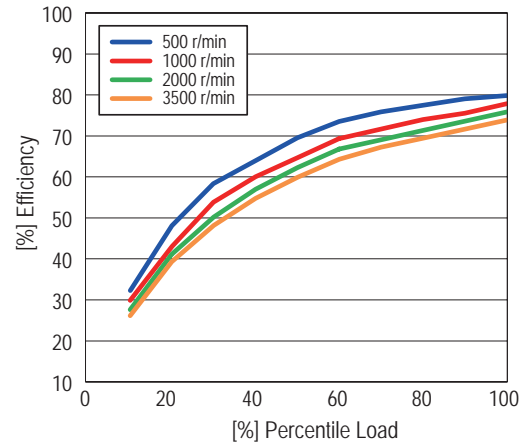

WPU-80-100

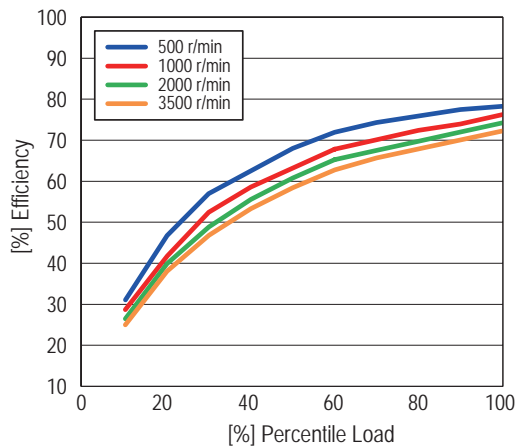

WPU-80-120

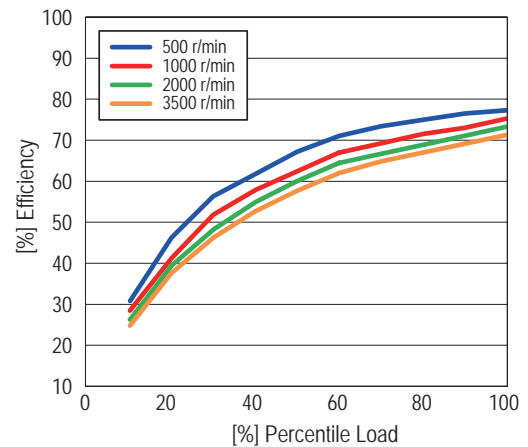

WPU-80-160

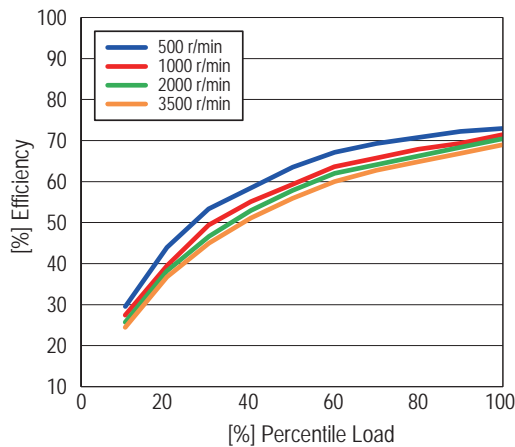

*1 These diagrams represent the average value of the actual measurement.
 *2 Charts does not show effects due to rotation resistance of bearings and oil seals on the input side.

Reducer Model/ Specifications
Dimensions
Life Estimation (Elastic Bearing)
Life Estimation (Main Bearing)
Maximum Load at Input Shaft
Lubricant Information
Attachment Fixture Requirement Info
Transmitting Torque
Input Section Structure/ Installation & Assembly
Motor Installation Procedure Info
Characteristics Data

Characteristics Data

Efficiency (Open type, Unit (Hollow shaft))

- Percentile load (%) is equal to load torque divided by allowable average torque.
- Ambient temperature: 25°C

WPU-35-50

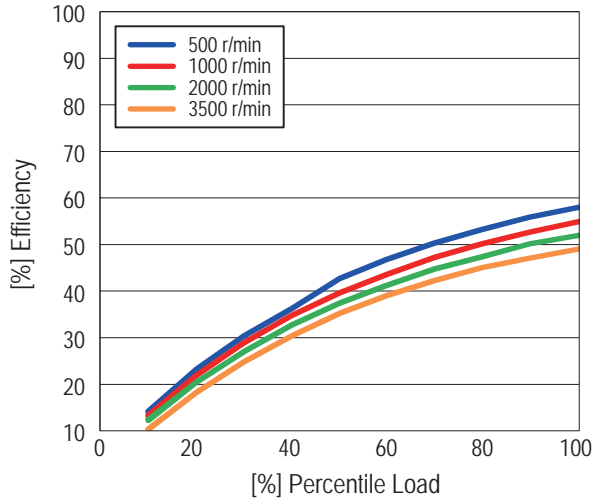

WPU-35-80

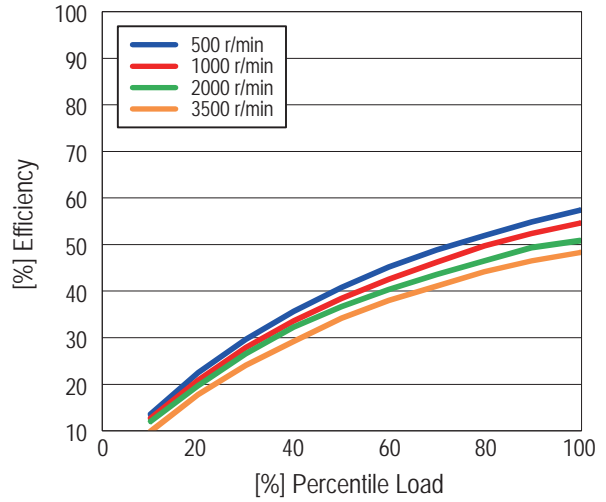

WPU-35-100

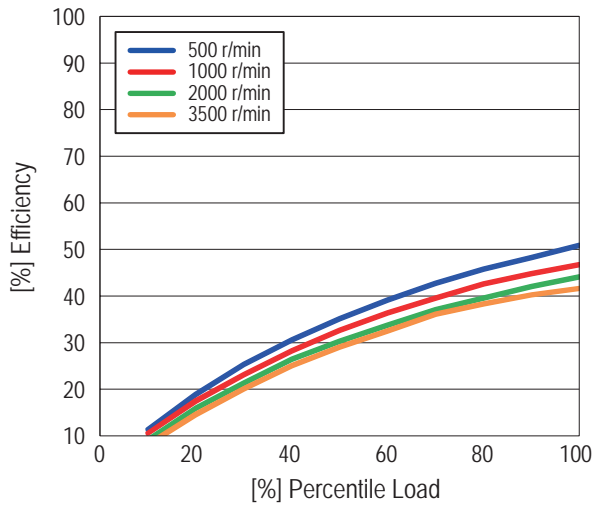

*1 These diagrams represent the average value of the actual measurement.

*2 Charts does not show effects due to rotation resistance of bearings and oil seals on the input side.

Characteristics Data

Efficiency (Open type, Unit (Hollow shaft))

- Percentile load (%) is equal to load torque divided by allowable average torque.
- Ambient temperature: 25°C

WPU-42-50

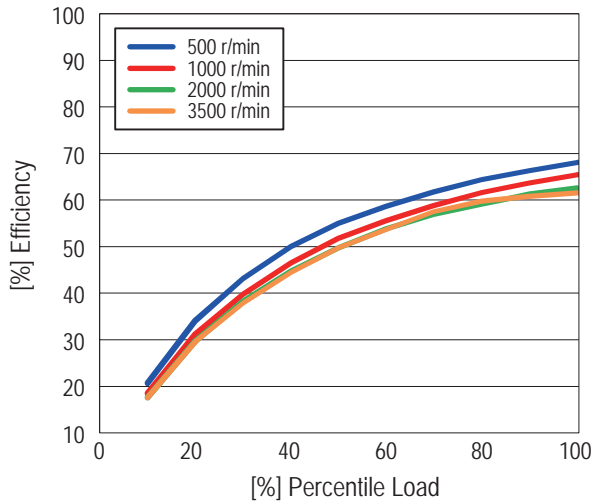

WPU-42-80

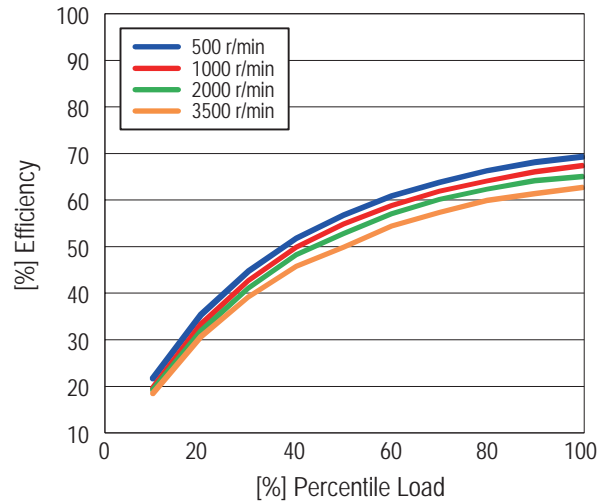

WPU-42-100

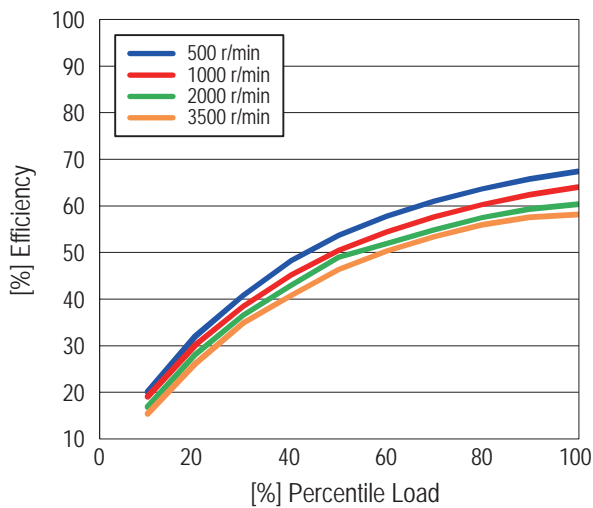

WPU-42-120

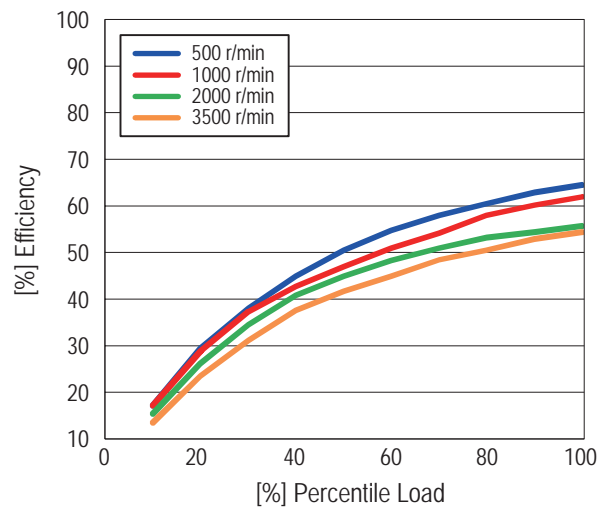

*1 These diagrams represent the average value of the actual measurement.
 *2 Charts does not show effects due to rotation resistance of bearings and oil seals on the input side.

Reducer Model/ Specifications
Dimensions
Life Estimation (Elastic Bearing)
Life Estimation (Main Bearing)
Maximum Load at Input Shaft
Lubricant Information
Attachment Fixture Requirement Info
Transmitting Torque
Input Section Structure/ Installation & Assembly
Motor Installation Procedure Info
Characteristics Data

Characteristics Data

Efficiency (Open type, Unit (Hollow shaft))

- Percentile load (%) is equal to load torque divided by allowable average torque.
- Ambient temperature: 25°C

WPU-50-50

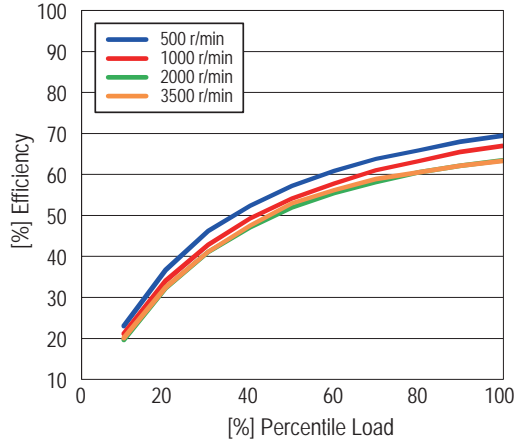

WPU-50-80

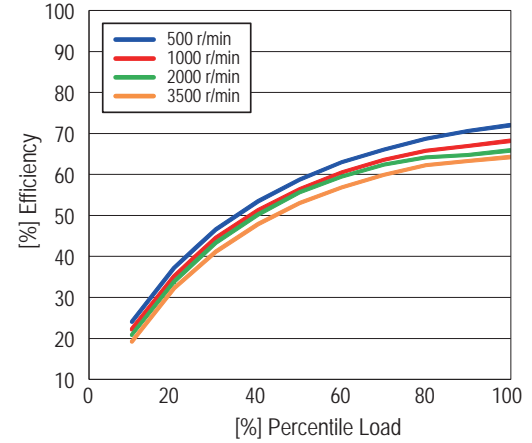

WPU-50-100

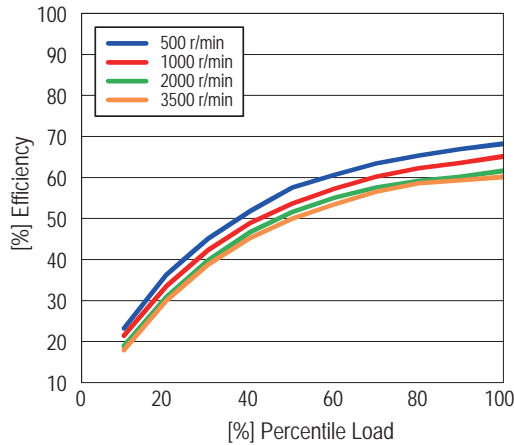

WPU-50-120

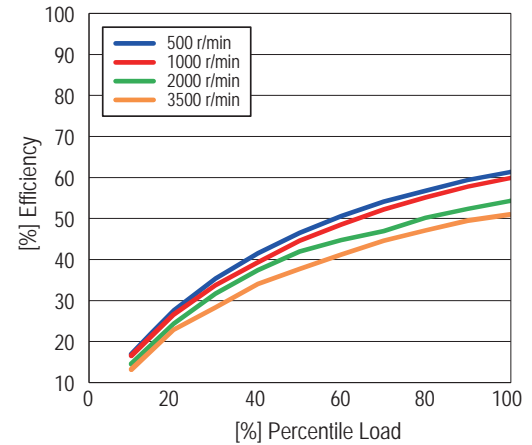

WPU-50-160

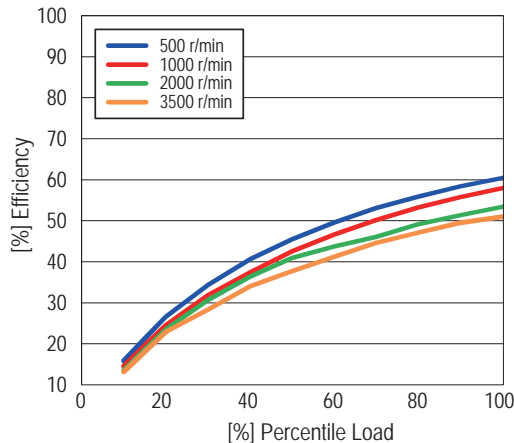

*1 These diagrams represent the average value of the actual measurement.

*2 Charts does not show effects due to rotation resistance of bearings and oil seals on the input side.

Characteristics Data

Efficiency (Open type, Unit (Hollow shaft))

- Percentile load (%) is equal to load torque divided by allowable average torque.
- Ambient temperature: 25°C

WPU-63-50

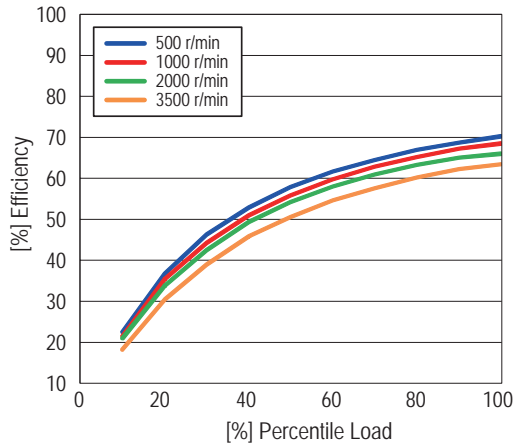

WPU-63-80

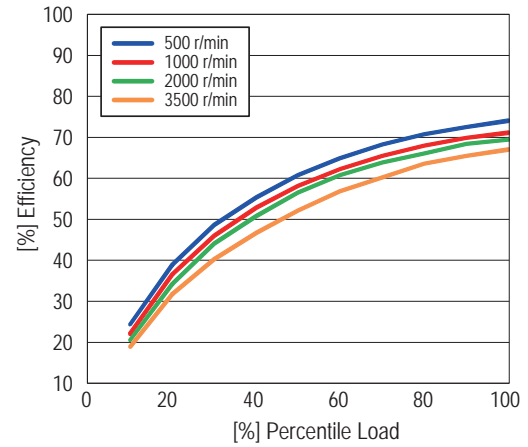

WPU-63-100

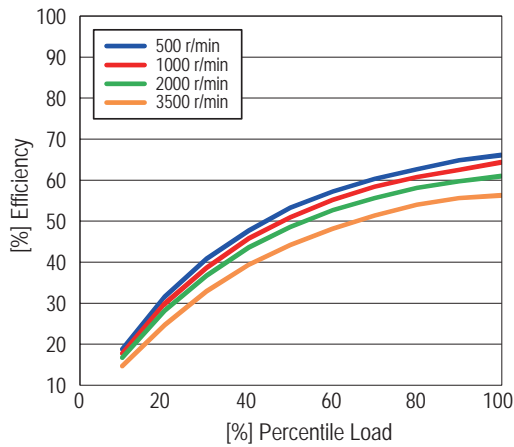

WPU-63-120

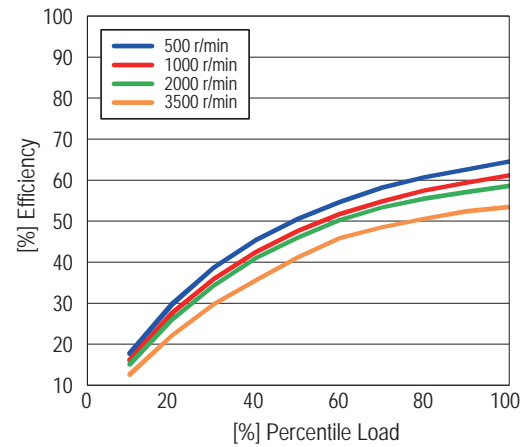

WPU-63-160

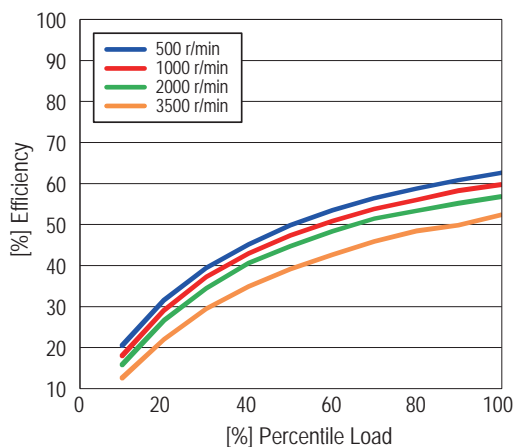

*1 These diagrams represent the average value of the actual measurement.
 *2 Charts does not show effects due to rotation resistance of bearings and oil seals on the input side.

Reducer Model/ Specifications	Dimensions	Life Estimation (Elastic Bearing)	Life Estimation (Main Bearing)	Maximum Load at Input Shaft	Lubricant Information	Attachment Fixture Requirement Info	Transmitting Torque	Input Section Structure/ Installation & Assembly	Motor Installation Procedure Info	Characteristics Data
----------------------------------	------------	--------------------------------------	-----------------------------------	--------------------------------	-----------------------	--	---------------------	---	--------------------------------------	----------------------

Characteristics Data

Efficiency (Open type, Unit (Hollow shaft))

- Percentile load (%) is equal to load torque divided by allowable average torque.
- Ambient temperature: 25°C

WPU-80-50

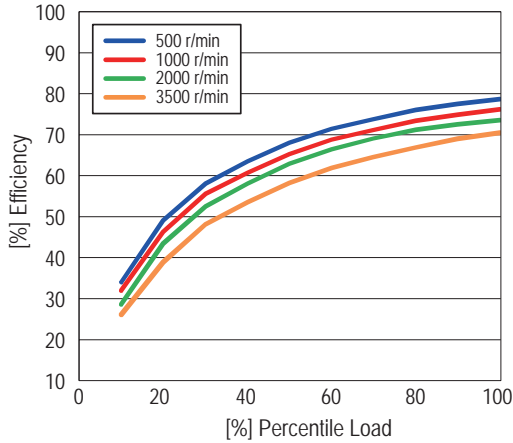

WPU-80-80

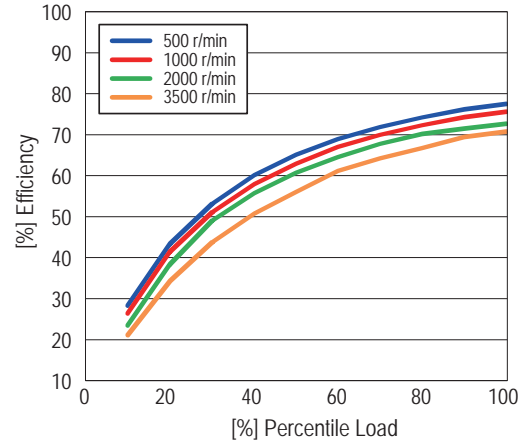

WPU-80-100

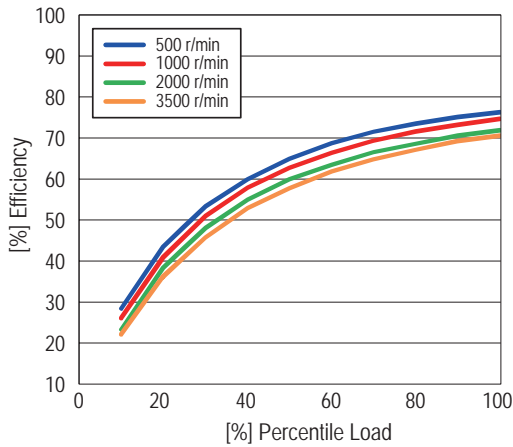

WPU-80-120

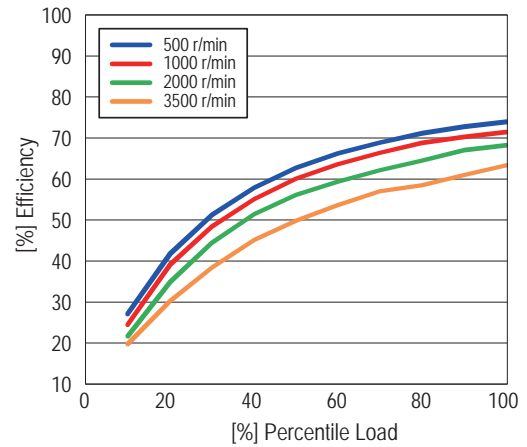

WPU-80-160

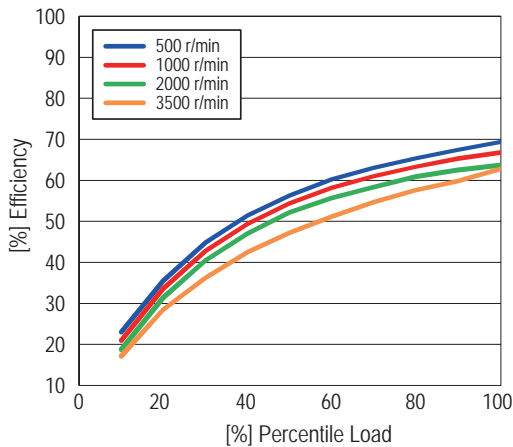

*1 These diagrams represent the average value of the actual measurement.

*2 Charts does not show effects due to rotation resistance of bearings and oil seals on the input side.

Characteristics Data

Efficiency (Open type, Unit (Input shaft))

- Percentile load (%) is equal to load torque divided by allowable average torque.
- Ambient temperature: 25°C

WPU-35-50

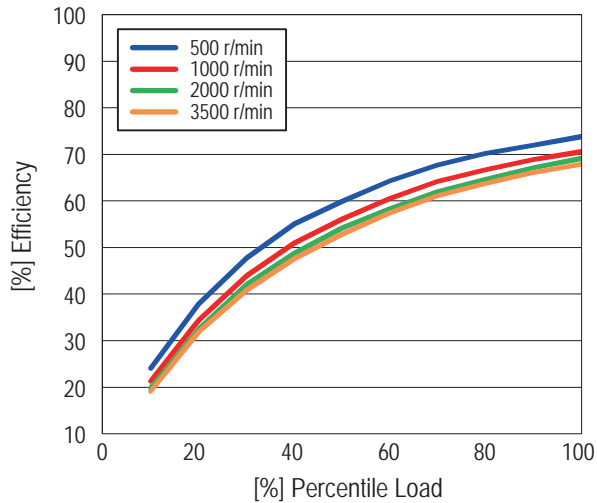

WPU-35-80

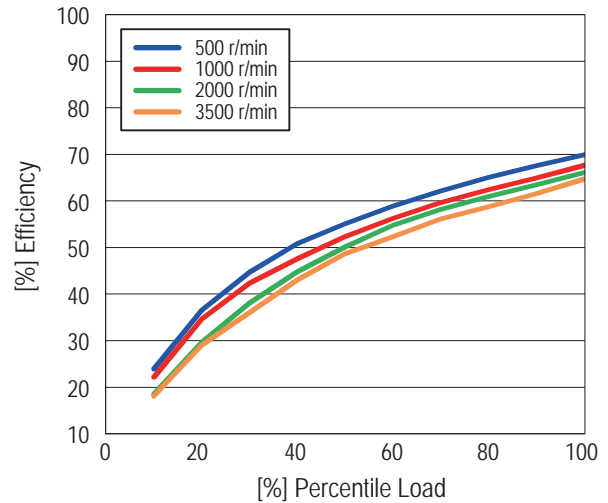

WPU-35-100

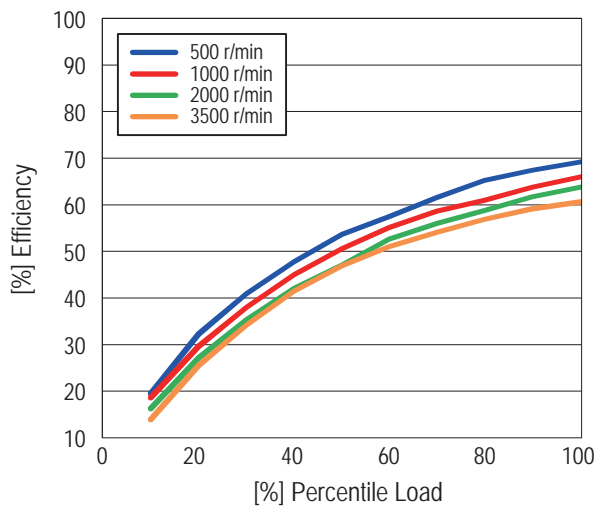

*1 These diagrams represent the average value of the actual measurement.
 *2 Charts does not show effects due to rotation resistance of bearings and oil seals on the input side.

Reducer Model/ Specifications	Dimensions	Life Estimation (Elastic Bearing)	Life Estimation (Main Bearing)	Maximum Load at Input Shaft	Lubricant Information	Attachment Fixture Requirement Info	Transmitting Torque	Input Section Structure/ Installation & Assembly	Motor Installation Procedure Info	Characteristics Data
----------------------------------	------------	--------------------------------------	-----------------------------------	--------------------------------	-----------------------	--	---------------------	---	--------------------------------------	----------------------

Characteristics Data

Efficiency (Open type, Unit (Input shaft))

- Percentile load (%) is equal to load torque divided by allowable average torque.
- Ambient temperature: 25°C

WPU-42-50

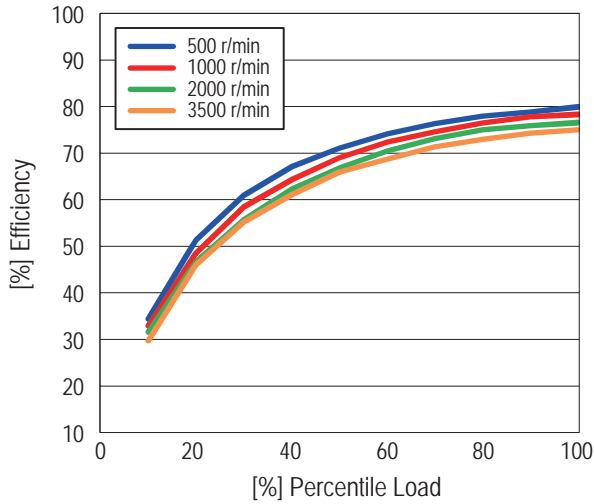

WPU-42-80

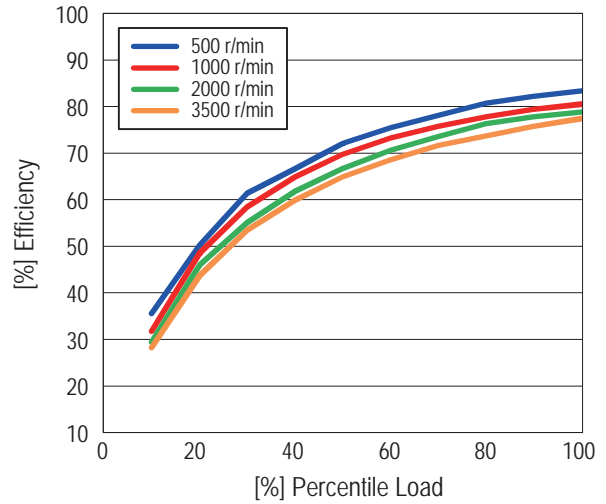

WPU-42-100

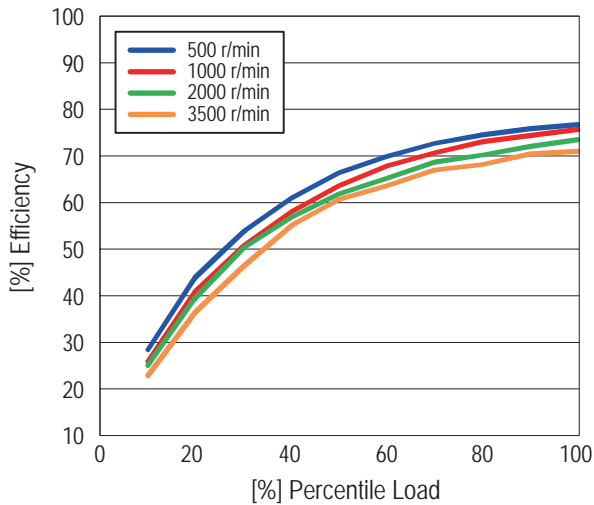

WPU-42-120

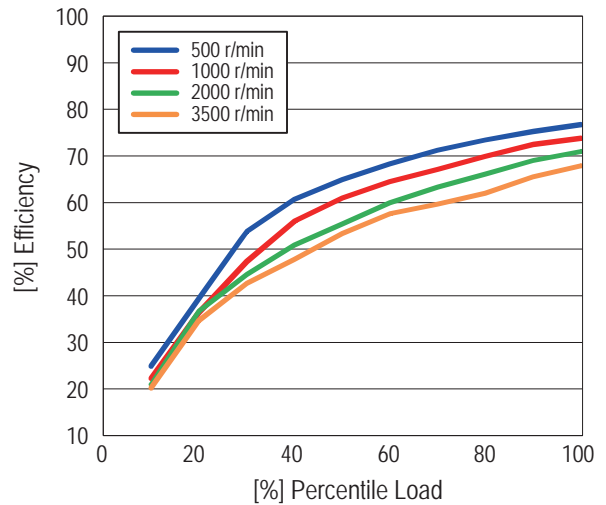

*1 These diagrams represent the average value of the actual measurement.

*2 Charts does not show effects due to rotation resistance of bearings and oil seals on the input side.

Characteristics Data

Efficiency (Open type, Unit (Input shaft))

- Percentile load (%) is equal to load torque divided by allowable average torque.
- Ambient temperature: 25°C

WPU-50-50

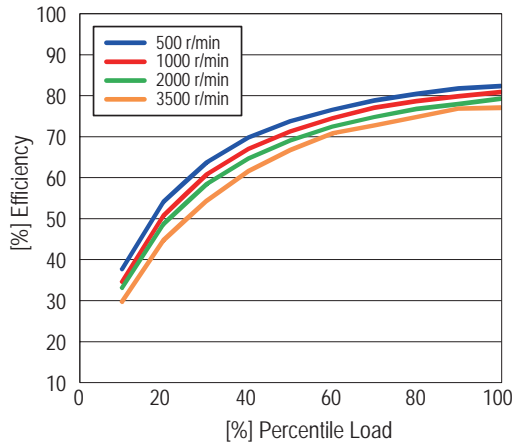

WPU-50-80

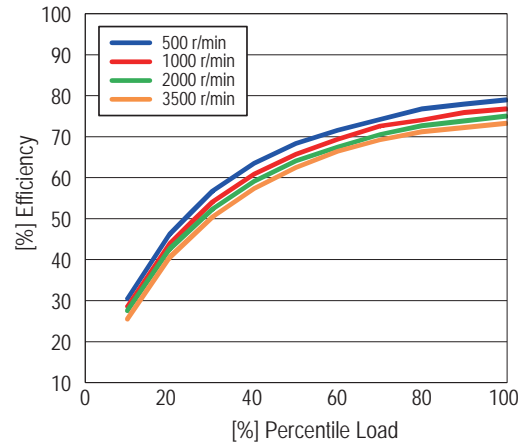

WPU-50-100

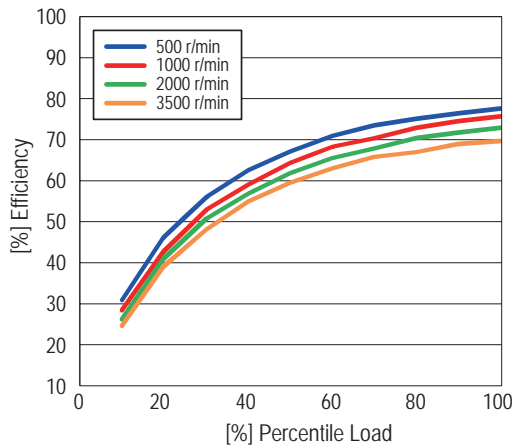

WPU-50-120

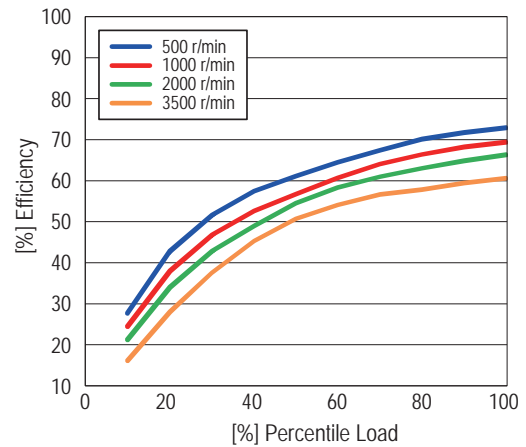

WPU-50-160

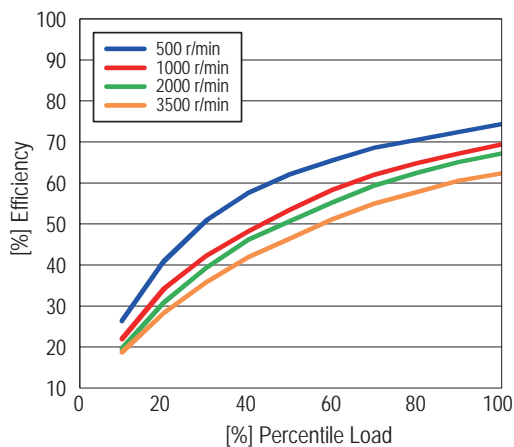

*1 These diagrams represent the average value of the actual measurement.

*2 Charts does not show effects due to rotation resistance of bearings and oil seals on the input side.

Reducer Model / Specifications
Dimensions
Life Estimation (Elastic Bearing)
Life Estimation (Main Bearing)
Maximum Load at Input Shaft
Lubricant Information
Attachment Fixture Requirement Info
Transmitting Torque
Input Section Structure / Installation & Assembly
Motor Installation Procedure Info
Characteristics Data

Characteristics Data

Efficiency (Open type, Unit (Input shaft))

- Percentile load (%) is equal to load torque divided by allowable average torque.
- Ambient temperature: 25°C

WPU-63-50

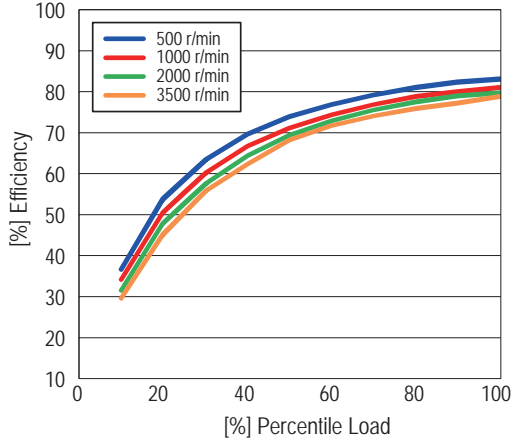

WPU-63-80

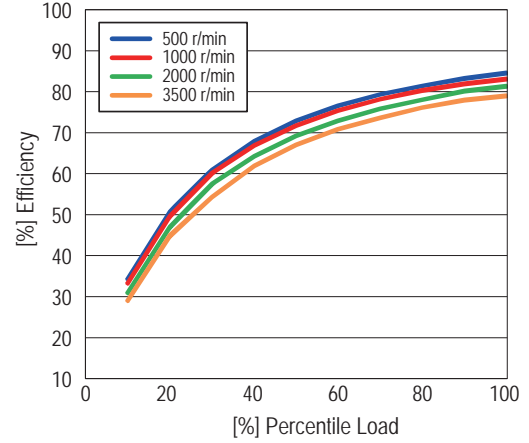

WPU-63-100

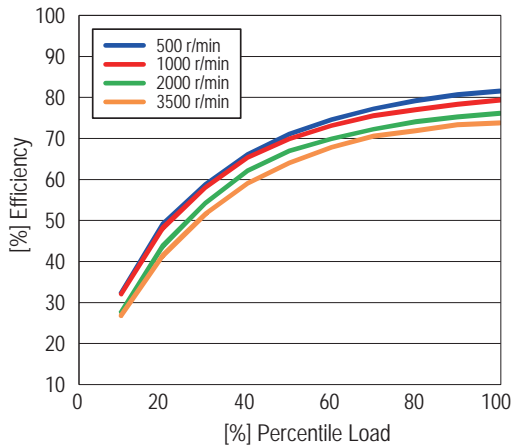

WPU-63-120

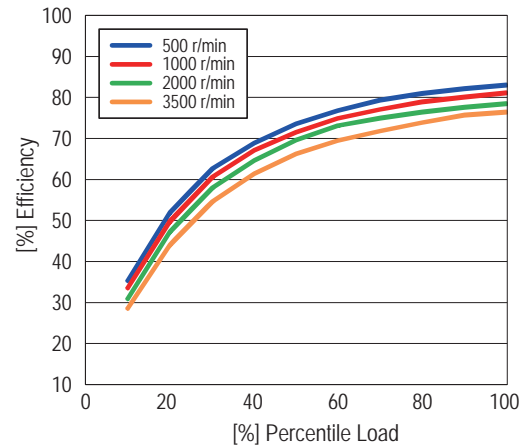

WPU-63-160

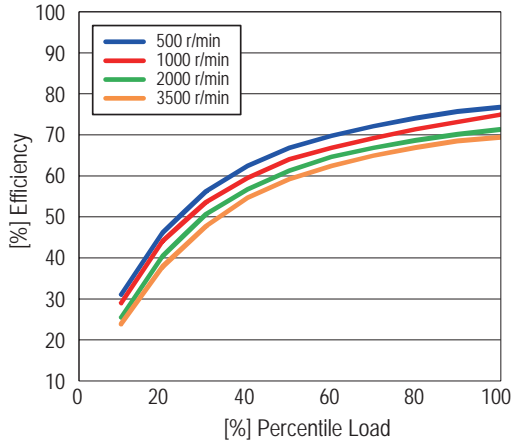

*1 These diagrams represent the average value of the actual measurement.

*2 Charts does not show effects due to rotation resistance of bearings and oil seals on the input side.

Characteristics Data

Efficiency (Open type, Unit (Input shaft))

- Percentile load (%) is equal to load torque divided by allowable average torque.
- Ambient temperature: 25°C

WPU-80-50

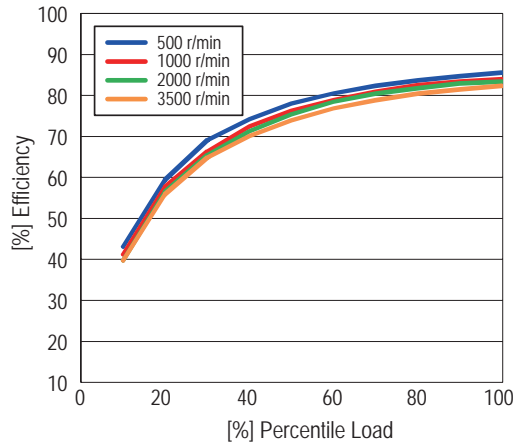

WPU-80-80

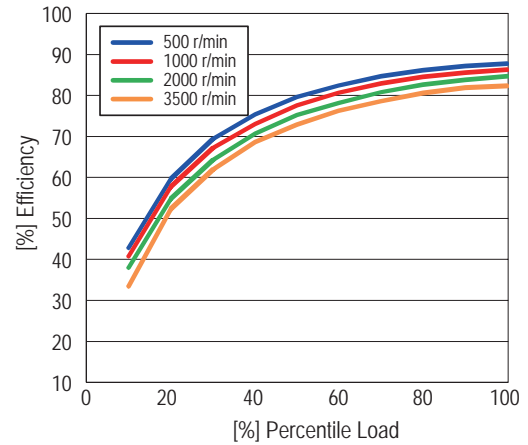

WPU-80-100

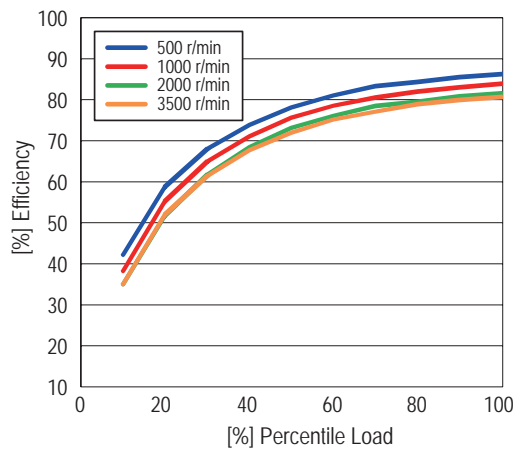

WPU-80-120

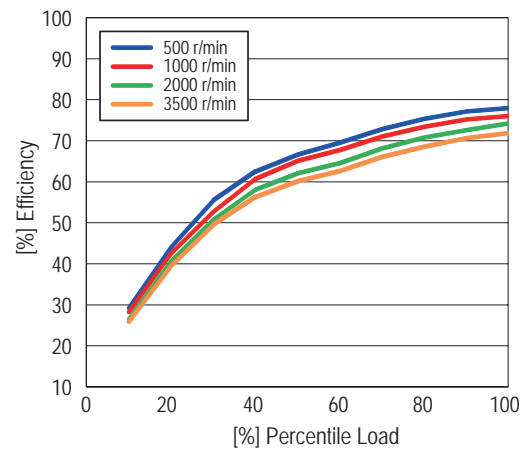

WPU-80-160

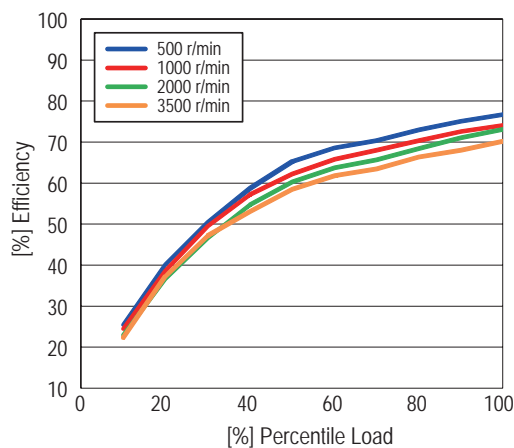

*1 These diagrams represent the average value of the actual measurement.
 *2 Charts does not show effects due to rotation resistance of bearings and oil seals on the input side.

Reducer Model/ Specifications	Dimensions	Life Estimation (Elastic Bearing)	Life Estimation (Main Bearing)	Maximum Load at Input Shaft	Lubricant Information	Attachment Fixture Requirement Info	Transmitting Torque	Input Section Structure/ Installation & Assembly	Motor Installation Procedure Info	Characteristics Data
----------------------------------	------------	--------------------------------------	-----------------------------------	--------------------------------	-----------------------	--	---------------------	---	--------------------------------------	----------------------

Reducer Model Nomenclature

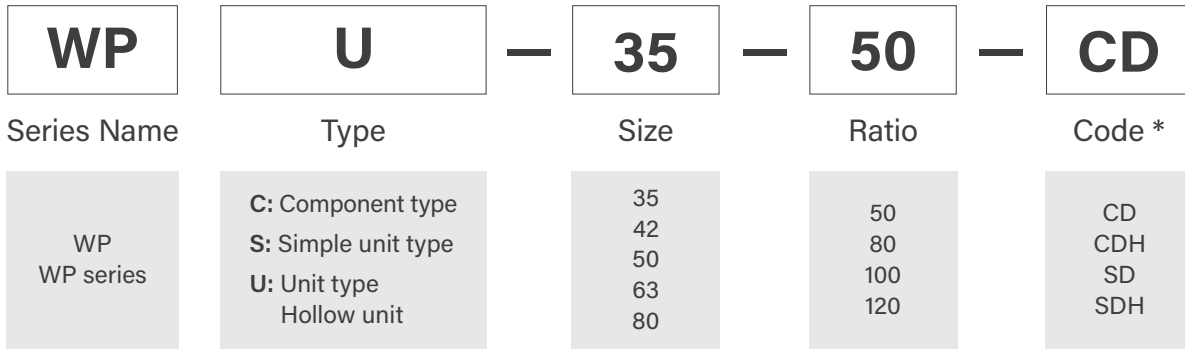

* For code details, check Dimensions Table

Ratio Matrix Availability

Frame Size	Reduction Ratio			
	50	80	100	120
35				
42				
50				
63				
80				

Reducer Specifications

Size	Ratio R*1	Nominal Output Torque *2	Maximum Output Torque *3	Emergency Stop Torque *4	Nominal Input Speed *5	Maximum Input Speed *6	Life *7
		[Nm]	[Nm]	[Nm]	[r/min]	[r/min]	[hours]
35	50	3.7	12	24	3000	8500	7000
	80	5.4	16	29			
	100	5.4	19	31			
42	50	11	23	48	3000	7300	
	80	15	29	52			
	100	16	37	55			
	120	16	37	55			
50	50	17	39	69	3000	6500	
	80	24	51	75			
	100	28	57	76			
	120	28	57	76			
63	50	27	69	127	3000	5600	
	80	44	96	147			
	100	47	110	152			
	120	47	110	152			
80	50	53	151	268	3000	4800	
	80	82	212	334			
	100	96	233	359			
	120	96	233	359			

*1 Reduction ratio is to be calculated by the formula in the previous page, using R value in this table.

*2 The maximum allowable value at the input rotation speed of 2000r/min

*3 The maximum torque when starting and stopping.

*4 The maximum torque when it receives shock.

*5 The maximum average input speed.

*6 The maximum input speed.

*7 The life time at the input rotation speed of 2000 r/min and nominal output torque.

Dimensions

Closed Type: Component

WPC-□-□-CD

Size	Weight	Moment of Inertia
	kg	$\times 10^{-4} \text{kgm}^2$
35	0.062	0.0226
42	0.10	0.0565
50	0.16	0.113
63	0.26	0.342
80	0.57	1.18

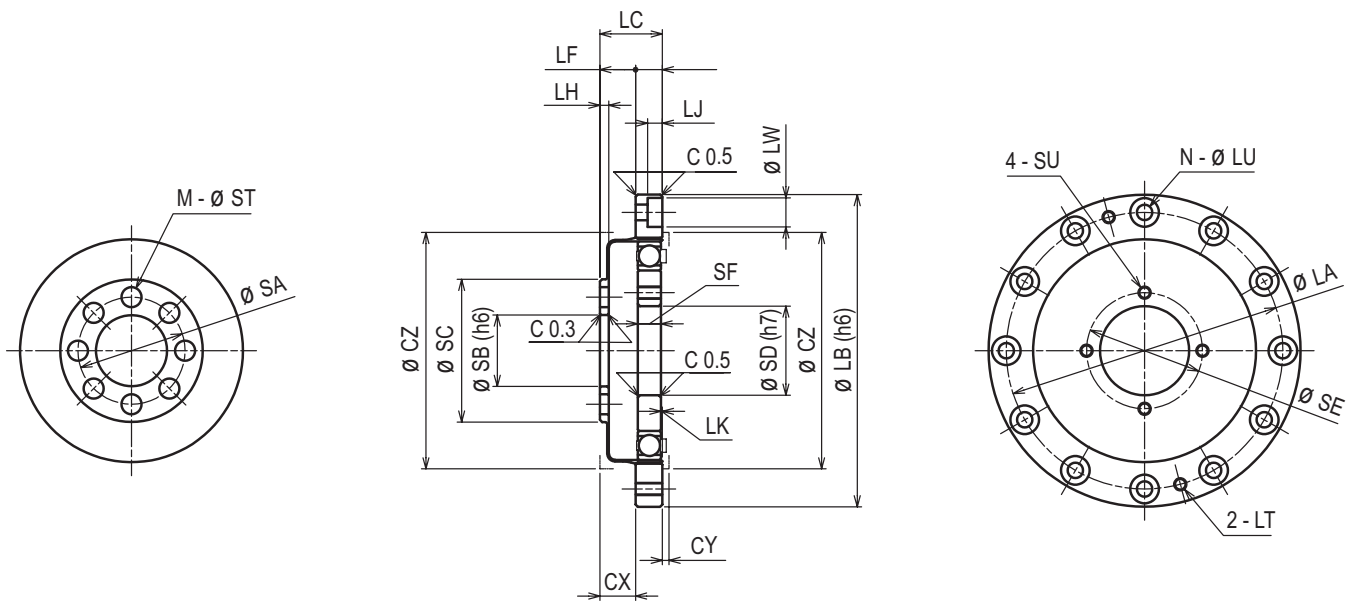

[mm]

Size	LA	LB	LE	LF	LG	LH	LJ	LK	N	LU	LW	LT
35	44	50	11	6.5	4.5	1.4	-	0.3	6	3.5	-	M3
42	54	60	12.5	7.5	5	1.7	-	0.3	8	3.5	-	M3
50	62	70	14	8	6	2	3.3	0.3	12	3.5	6.5	M3
63	75	85	17	10	7	2	3.3	0.4	12	3.5	6.5	M3
80	100	110	22	13	9	2.5	4.4	0.5	12	4.5	8	M4

Size	SA	SB	SC	SD	SE	SF	CX	CY	CZ	M	ST	SU
35	17	11	23.5	11	17	4	6.5	1	38	8	3.5	M3
42	19.5	11	27	15	21	5	7.5	1	45	8	4.5	M3
50	24	16	32	20	26	5.2	8	1.5	53	8	4.5	M3
63	30	20	40	24	30	6.3	10	1.5	66	8	5.5	M3
80	41	30	52	32	40	8.6	13	2	86	10	6.5	M4

* Inner dimensions of CX, CY, CZ are recommended dimensions.

Reducer Model/ Specifications | Dimensions | Life Estimation (Elastic Bearing) | Life Estimation (Main Bearing) | Maximum Load at Input Shaft | Lubricant Information | Attachment Fixture Requirement Info | Transmitting Torque | Installation & Assembly | Characteristics Data

Dimensions

Closed Type: Unit

WPU-□-□-CD



Size	Weight	Moment of Inertia
	kg	$\times 10^{-4} \text{kgm}^2$
35	0.33	0.0227
42	0.43	0.0565
50	0.61	0.113
63	1.1	0.343
80	2.2	1.18

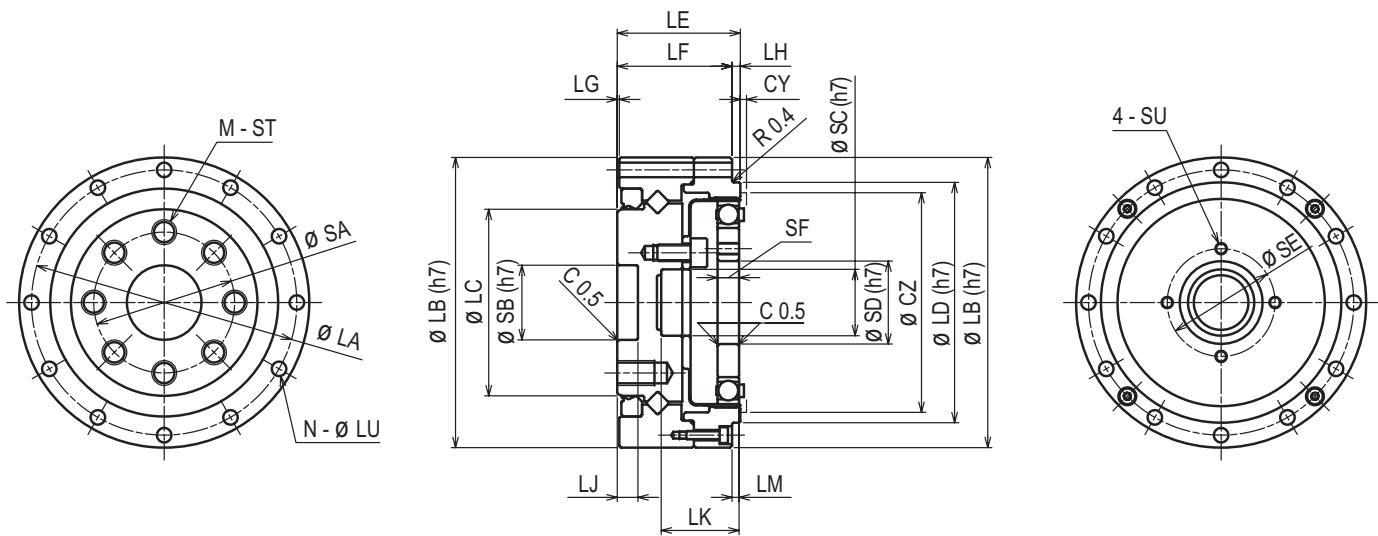

[mm]

Size	LA	LB	LC	LD	LE	LF	LG	LH	LJ	LK	LM	N	LU
35	49	55	31	42.5	25	23	0.5	2	5	14.8	1.7	6	3.5
42	56	62	38	49.5	26.5	24.5	0.5	2	5	16.3	1.7	10	3.5
50	64	70	45	58	29.7	27.7	0.5	2	5	18.8	1.7	12	3.5
63	79	85	58	73	37.1	34.1	0.5	3	5.5	23.6	2.6	18	3.5
80	104	112	78	96	43	40	1	3	5.5	30.6	2.5	18	4.5

Size	SA	SB	SC	SD	SE	SF	CY	CZ	M	ST	SU
35	25	12	11	11	17	4	1	38	10	M3 × 6	M3
42	27	14	11	15	21	5	1	45	8	M5 × 8	M3
50	34	18	16	20	26	5.2	1.5	53	8	M6 × 9	M3
63	42	24	20	24	30	6.3	1.5	66	8	M8 × 12	M3
80	57	32	30	32	40	8.6	2	86	10	M8 × 12	M4

* Inner dimensions of CY, CZ are recommended dimensions.

Dimensions

Open Type: Unit

WPU-□-□-CDH

Size	Weight	Moment of Inertia
	kg	$\times 10^{-4} \text{kgm}^2$
35	0.46	0.0228
42	0.63	0.0571
50	0.91	0.113
63	1.6	0.344
80	3.0	1.18

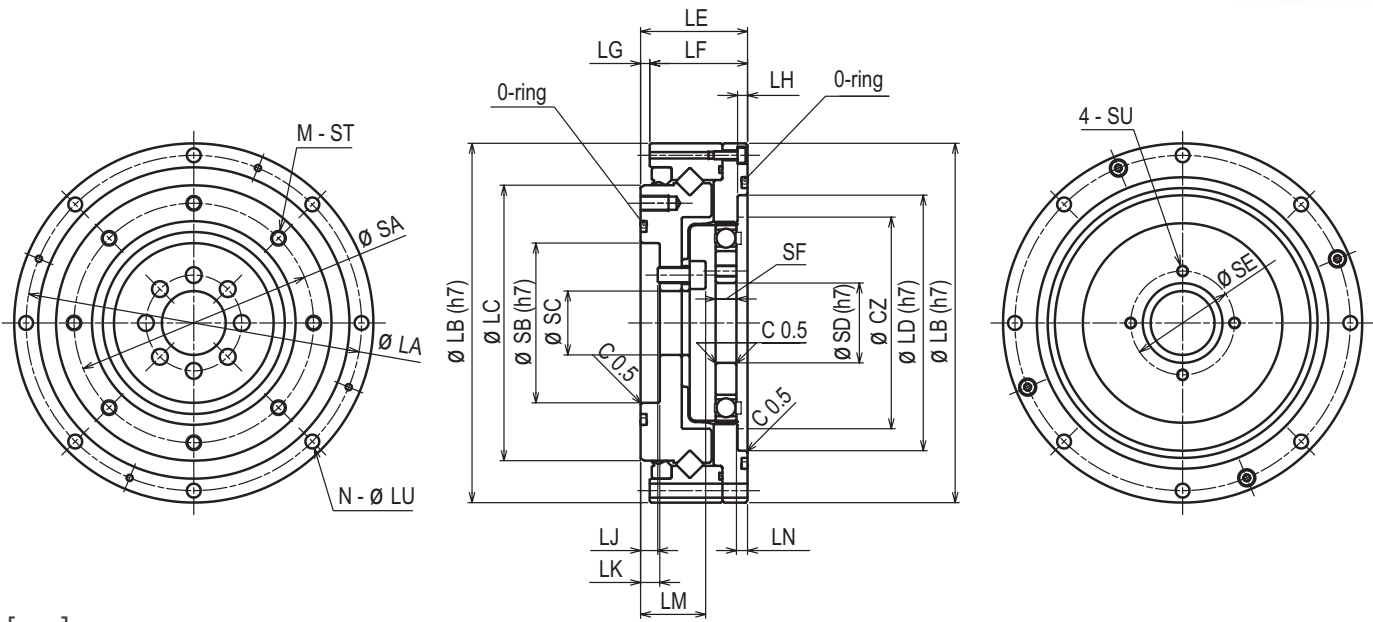

[mm]

Size	LA	LB	LC	LD	LE	LF	LG	LH	LJ	LK	LM	LN	N	LU
35	64	70	49	48	22	21.5	0.5	2.5	3.9	4.9	12.9	2.8	6	3.5
42	74	80	59	56	22.7	22.2	0.5	2.5	1.4	3.7	13.4	2.8	8	3.5
50	84	90	69	64	26.8	24.5	2.3	2.5	4.3	4.8	16.3	2.8	8	3.5
63	102	110	84	80	31.5	29.4	2.1	3	3.5	5.5	18.5	3.4	10	4.5
80	132	142	110	106	37	34.2	2.8	3	2.5	6	20.5	3.5	10	5.5

Size	SA	SB	SC	SD	SE	SF	CZ	M	ST	SU
35	42	30	11	11	17	4	38	8	M3 × 5	M3
42	50	34	11	15	21	5	45	10	M3 × 6	M3
50	60	40	16	20	26	5.2	53	8	M4 × 7	M3
63	73	52	20	24	30	6.3	66	8	M5 × 8	M3
80	96	70	30	32	40	8.6	86	8	M6 × 10	M4

* Inner dimensions of CY, CZ are recommended dimensions.

Reducer Model / Specifications
 Dimensions
 Life Estimation (Elastic Bearing)
 Life Estimation (Main Bearing)
 Maximum Load at Input Shaft
 Lubricant Information
 Attachment Fixture Requirement Info
 Transmitting Torque
 Installation & Assembly
 Characteristics Data

Dimensions

Open Type, Simple Unit

WPS-□-□-SD

Size	Weight	Moment of Inertia
	kg	$\times 10^{-4} \text{kgm}^2$
35	0.31	0.0233
42	0.43	0.0578
50	0.54	0.114
63	0.93	0.347
80	2.0	1.20

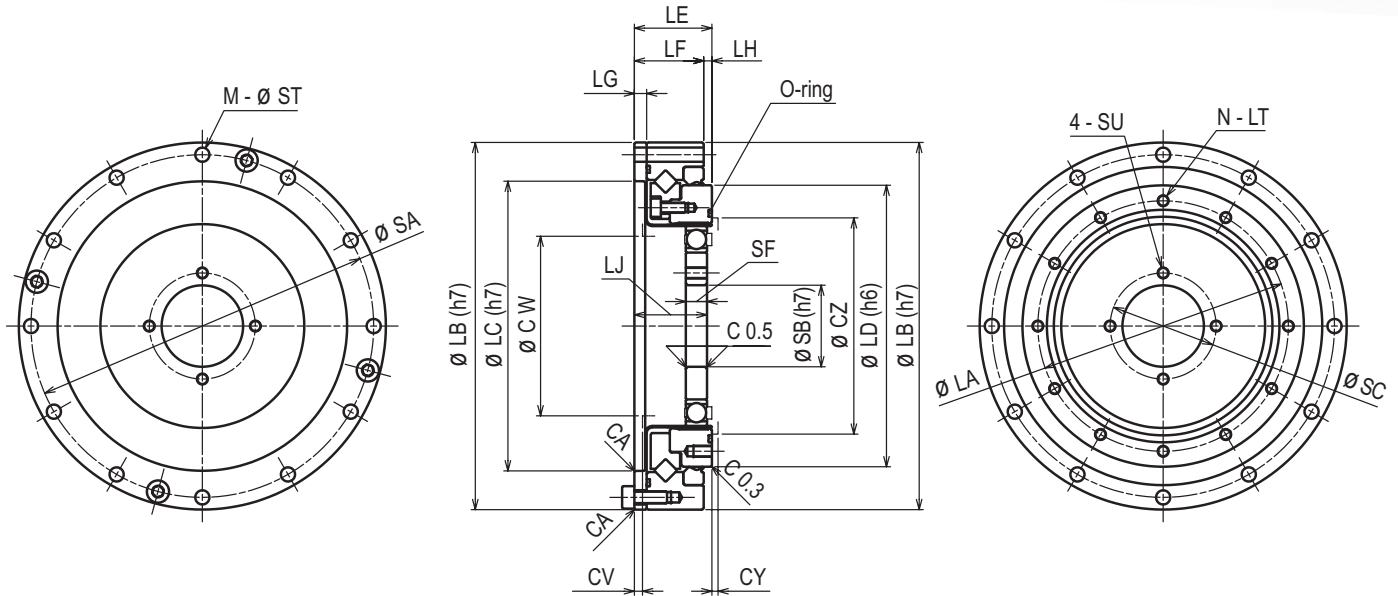
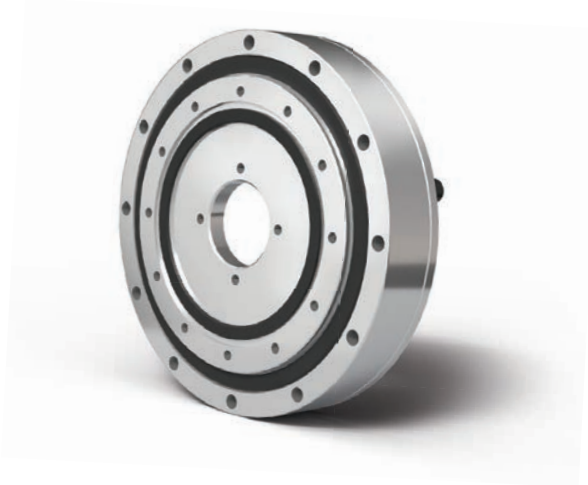

[mm]

Size	LA	LB	LC	LD	LE	LF	LG	LH	LJ	N	LT
35	43	70	50	49	17.5	15.5	2.4	2	15.7	8	M3 × 4.5
42	52	80	61	59	18.5	16.5	3	2	16.9	12	M3 × 4.5
50	61.4	90	71	69	19	17	3	2	17.8	12	M3 × 4.5
63	76	110	88	84	22	20	3.3	2	21.6	12	M4 × 6
80	99	142	114	110	27.9	23.6	3.6	4.3	27.3	12	M5 × 8

Size	O-ring
35	38.0 × 0.8
42	45.0 × 0.8
50	55.0 × 1.2
63	68.0 × 1.2
80	86.0 × 1.2

Size	SA	SB	SC	SF	CA	CY	CZ	CV	CW	M	ST	SU
35	64	11	17	4	0.3	1	36.5	1.6	31	8	3.5	M3
42	74	15	21	5	0.3	1	43.5	2	37	12	3.5	M3
50	84	20	26	5.2	0.3	1.5	53	2	44	12	3.5	M3
63	102	24	30	6.3	0.3	1.5	66	2	56	12	4.5	M3
80	132	32	40	8.6	0.5	2	84	2	72	12	5.5	M4

Dimensions

Open Type, Unit (Hollow Shaft)

WPU-□-□-SDH

Size	Weight	Moment of Inertia
	kg	$\times 10^{-4} \text{kgm}^2$
35	0.49	0.0839
42	0.66	0.180
50	0.84	0.352
63	1.4	0.940
80	2.8	3.47

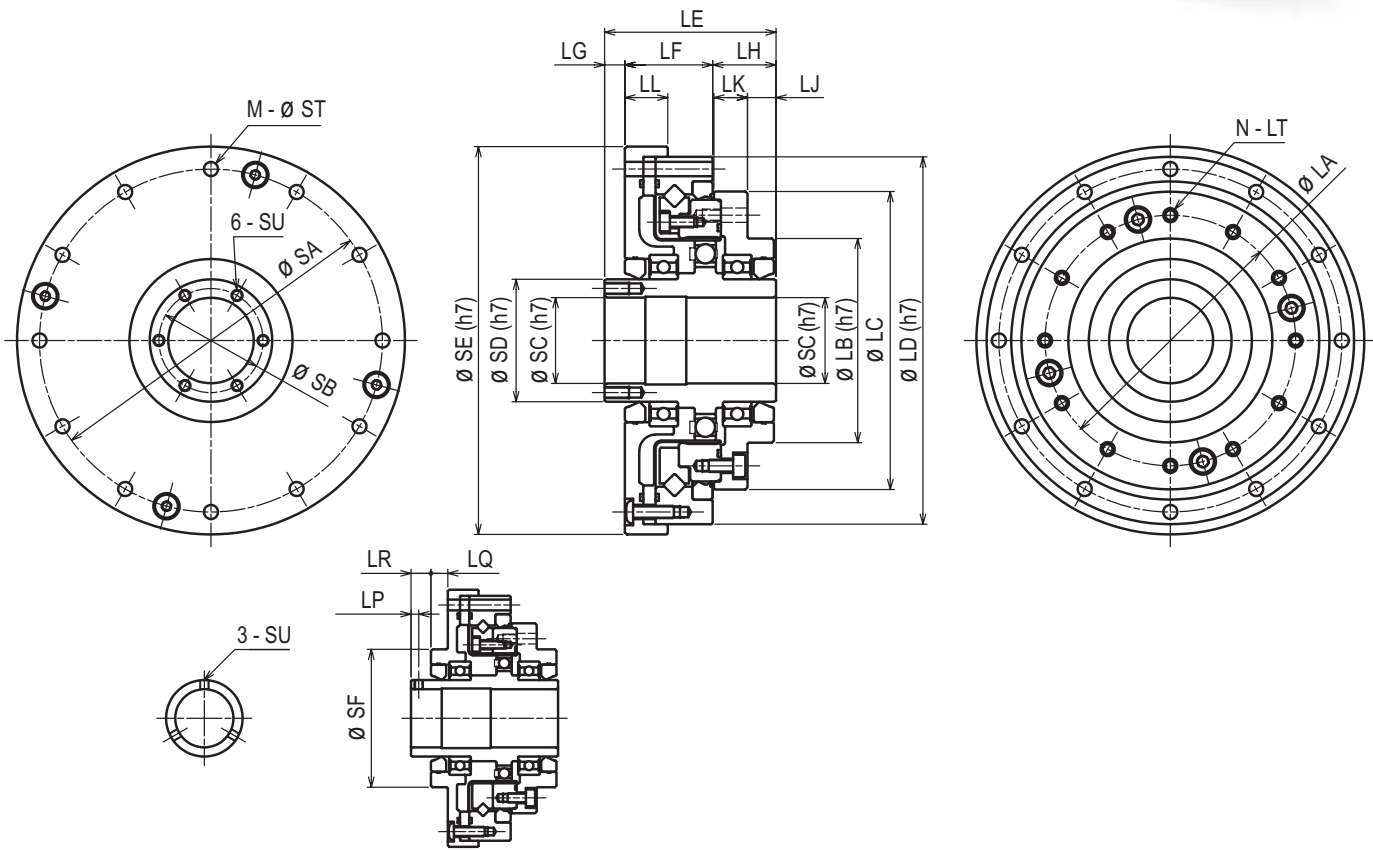

[mm]

INPUT SHAFT FOR 35 & 42

Size	LA	LB	LC	LD	LE	LF	LG	LH	LJ	LK	LL	LP	LQ	LR
35	43	36	52	70	45.5	19.5	12	14	6.5	7.5	9	2.5	5.5	6.5
42	52	45	62	80	48	20.5	12	15.5	7	8.5	10	2.5	5.5	6.5
50	61.4	50	73	90	42	21.5	5	15.5	7	8.5	10.5	-	-	-
63	76	60	87	110	46.5	24	6	16.5	6	10.5	10.5	-	-	-
80	99	75	114	142	55	28.6	7	19.4	7.5	11.9	12	-	-	-

Size	SA	SB	SC	SD	SE	SF	M	ST	SU	N	LT
35	64	-	14	20	74	36	8	3.5	M3	8	M3 × 4.5, Ø 3.5 × 5.5
42	74	-	19	25	84	45	12	3.5	M3	12	M3 × 4.5, Ø 3.5 × 6.5
50	84	25.5	21	30	95	-	12	3.5	M3 × 6	12	M3 × 4.5, Ø 3.5 × 6.5
63	102	33.5	29	38	115	-	12	4.5	M3 × 6	12	M4 × 6, Ø 4.5 × 8.5
80	132	48	41	54	147	-	12	5.5	M3 × 6	12	M5 × 8, Ø 5.5 × 7.6

Reducer Model / Specifications
 Dimensions
 Life Estimation (Elastic Bearing)
 Life Estimation (Main Bearing)
 Maximum Load at Input Shaft
 Lubricant Information
 Attachment Fixture Requirement Info
 Transmitting Torque
 Installation & Assembly
 Characteristics Data

Life Estimation (Elastic Bearing)

Life span for the elastic bearing

Operation Cycle Example

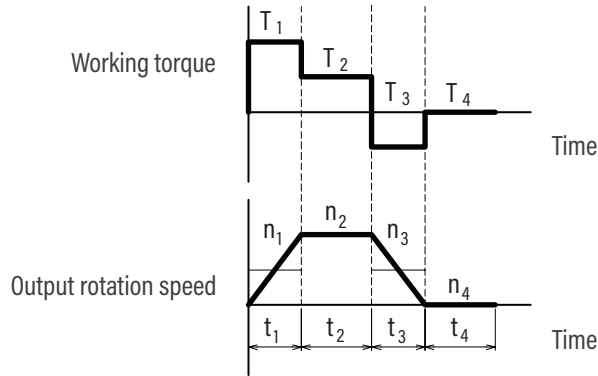

Calculation formula for output torque

Average output torque	Tao	Nm	$T_{ao} = \sqrt[3]{\frac{n_1 \cdot t_1 \cdot T_1 ^3 + n_2 \cdot t_2 \cdot T_2 ^3 + \dots + n_n \cdot t_n \cdot T_n ^3}{n_1 \cdot t_1 + n_2 \cdot t_2 + \dots + n_n \cdot t_n}}$
Peak output torque value	Tmo	Nm	$T_{mo} = \text{maximum value of } T_1, T_2, \dots, T_n$

Please make sure the peak output torque is below the maximum output torque in the specification table.

Calculation formula for input speed

Average output rotation speed	nao	r/min	$n_{ao} = \frac{n_1 \cdot t_1 + n_2 \cdot t_2 + \dots + n_n \cdot t_n}{t_1 + t_2 + \dots + t_n}$
Peak output rotation speed	nmo	r/min	$n_{mo} = \text{maximum value of } n_1, n_2, \dots, n_n$
Average input speed	nai	r/min	$n_{ai} = n_{ao} \times R \text{ (} R = \text{ratio)}$
Peak input speed value	nmi	r/min	$n_{mi} = n_{mo} \times R \text{ (} R = \text{ratio)}$

Please make sure the peak input speed value is below the maximum input speed in the specification table.

Calculation formula for life span

Part life span for the elastic bearing	Lhe	h	$L_{he} = 7000 \times \left(\frac{T_{ar}}{T_{ao}}\right)^3 \times \left(\frac{n_{ar}}{n_{ai}}\right)$
Rating torque	Tar	Nm	Nominal output torque in the specification table
Rating input rotation speed	nar	r/min	2000 r/min

Life Estimation (Main Bearing)

Model selection / Life estimation

Main bearing specification (Cross roller bearing)

Series	Size	Pitch Circle Diameter of the Bearing Rollers	Offset	Basic Dynamic Load Rating	Basic Static Load Rating	Allowable Moment	Moment Rigidity
		Dm	L	C	Co	Mal	Km
		m	m	N	N	Nm	$\times 10^4 \text{ Nm/rad}$
WPU-□-□-CD	35	0.034	0.009	5620	6540	36.5	7.35
	42	0.041	0.010	6340	8170	55.8	8.02
	50	0.049	0.011	10400	13300	91.0	13.5
	63	0.062	0.013	15800	21100	156	27.7
	80	0.082	0.013	24400	35600	313	66.0
WPU-□-□-CDH	35	0.051	0.006	7110	10200	74.0	14.4
	42	0.060	0.007	10900	15200	124	19.7
	50	0.071	0.008	17200	24700	187	40.1
	63	0.086	0.009	25100	37400	258	71.5
	80	0.114	0.011	43300	67600	580	188
WPS-□-□-SD	35	0.051	0.011	8010	11400	37.0	8.86
	42	0.061	0.011	7370	10900	62	20.8
	50	0.072	0.011	8030	12800	93	22.5
	63	0.087	0.013	14300	24500	129	33.3
	80	0.113	0.018	23700	42500	290	84.5
WPU-□-□-SDH	35	0.051	0.017	8010	11400	37.0	8.86
	42	0.061	0.018	7370	10900	62	20.8
	50	0.072	0.018	8030	12800	93	22.5
	63	0.087	0.021	14300	24500	129	33.3
	80	0.113	0.026	23700	42500	290	84.5

External load

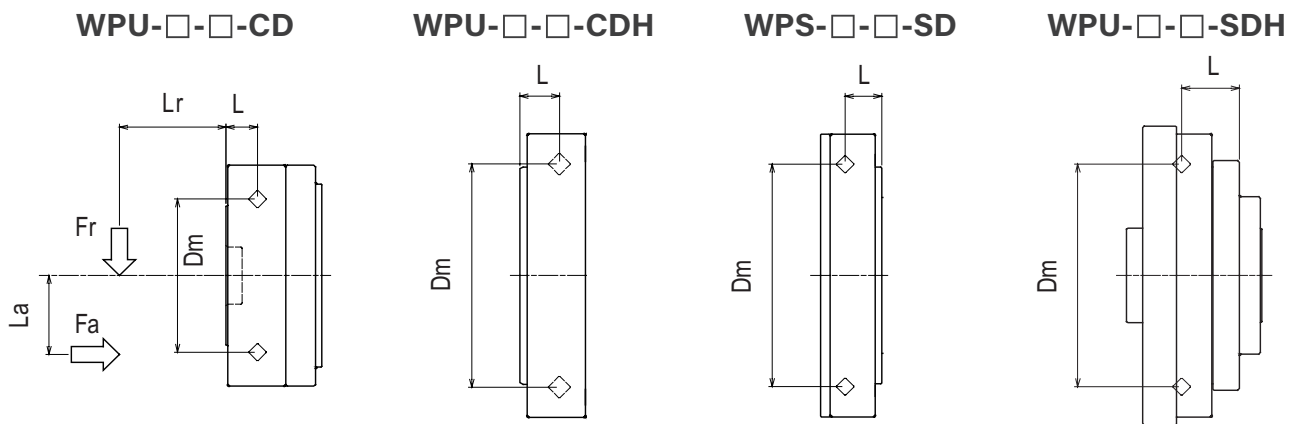

Reducer Model/
Specifications

Dimensions

Life Estimation
(Elastic Bearing)

Life Estimation
(Main Bearing)

Maximum Load
at Input Shaft

Lubricant Information

Attachment Fixture
Requirement Info

Transmitting Torque

Installation & Assembly

Characteristics Data

Maximum Load at Input Shaft

Bearing specification (Open type, Unit)

Series	Size	A Bearing A		B Bearing B		a	b
		Basic Dynamic Load Rating	Basic Static Load Rating	Basic Dynamic Load Rating	Basic Static Load Rating		
		C	Co	C	Co		
		N	N	N	N		
		mm		mm			
WPU-□-□-SDH	35	4000	2470	4000	2470	16.0	20.0
	42	4300	2950	4300	2950	16.0	22.5
	50	4500	3450	4500	3450	14.5	18.0
	63	4900	4350	4900	4350	15.5	21.8
	80	8800	8500	6400	6200	17.0	28.5

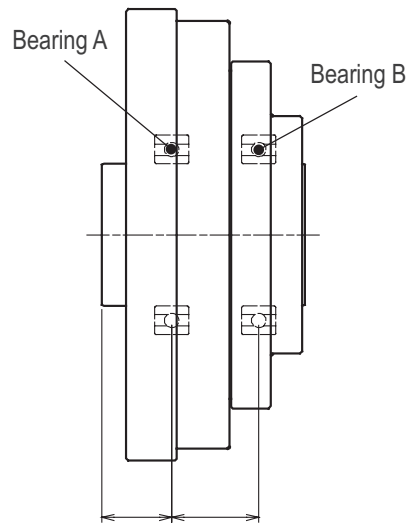

Maximum load (Average input rotation speed : 2000r/min, Life span : 7000h)

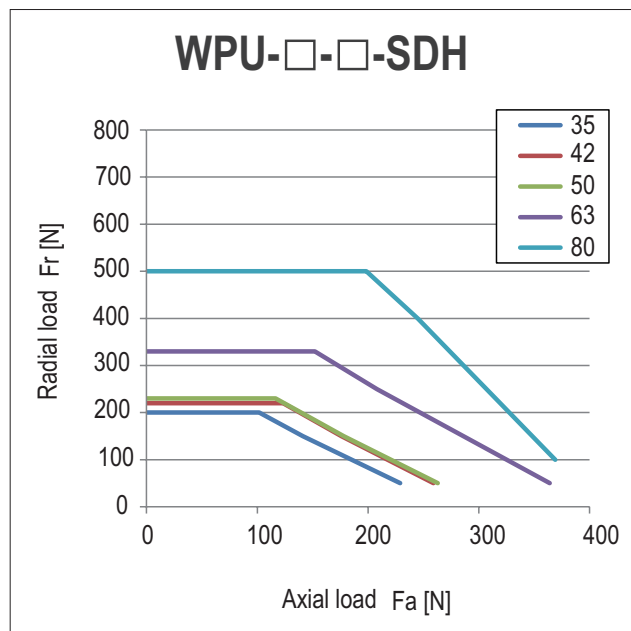

Lubricant Information

Grease

Sumiplex MP No.2 (SUMICO LUBRICANT CO., LTD.)

Operating temperature range: 0~40°C (ambient temperature)

Grease application

- The quantity of grease applied to C should be adjusted depending on the mounting direction. C of the unit type product is already filled with the same quantity of grease as horizontal mounting.
- For vertical up/down, 50% of the space between input assy and casing inner wall should be filled with grease.
- If the amount of grease is not sufficient due to case design, please contact us.

Please apply grease according to the table below.

[grams]

Size	Applied part					
	A	B	C Horizontal	C Vertical Up	C Vertical Down	D
35	0.2	0.2	3	4	5	0.2
42	0.3	0.3	5	6	7	0.3
50	0.4	0.4	8	9	11	0.4
63	1.8	0.8	16	19	21	0.8
80	1.5	1.5	36	42	48	1.5

Grease application location

WPC-□-□-CD

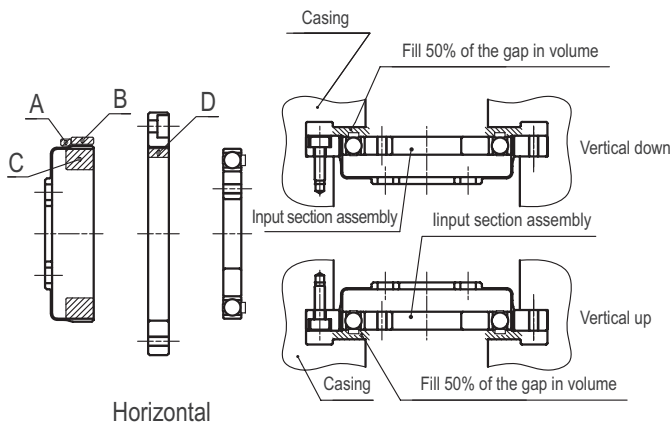

WPU-□-□-CD

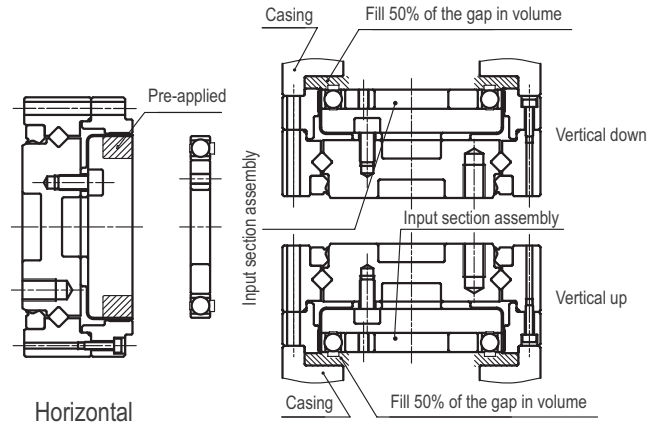

WPU-□-□-CDH

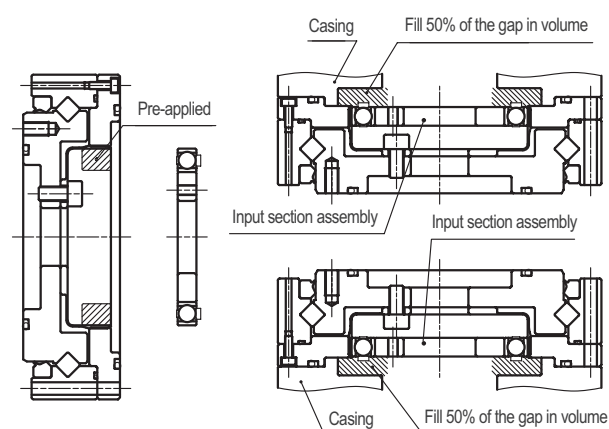

WPS-□-□-SD

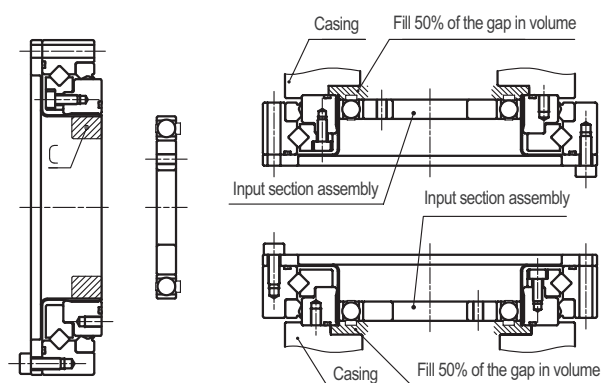

Reducer Model/
Specifications

Dimensions

Life Estimation
(Elastic Bearing)

Life Estimation
(Main Bearing)

Maximum Load
at Input Shaft

Lubricant Information

Attachment Fixture
Requirement Info

Transmitting Torque

Installation & Assembly

Characteristics Data

Attachment Fixture Requirement

Attachment fixture requirement

WPC-□-□-CD

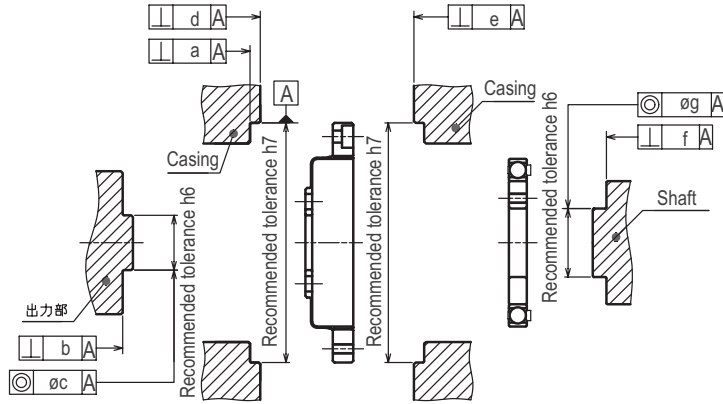

Installation accuracy [mm]

Size	35	42	50	63	80
a	0.015	0.015	0.018	0.018	0.023
b	0.010	0.012	0.014	0.016	0.020
c	0.013	0.013	0.015	0.018	0.020
d	0.015	0.015	0.018	0.018	0.023
e	0.015	0.015	0.018	0.018	0.023
f	0.012	0.012	0.014	0.016	0.016
g	0.016	0.020	0.024	0.024	0.024

WPU-□-□-CD

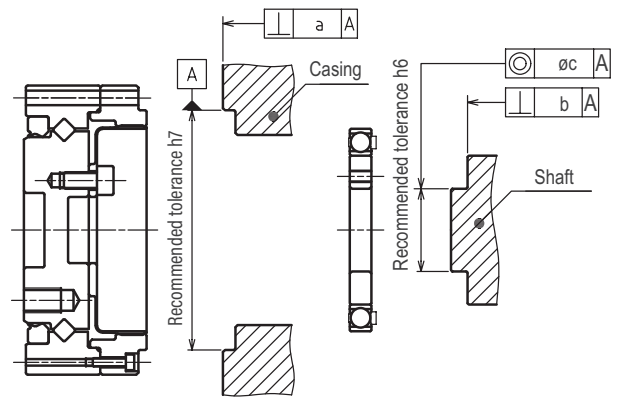

Installation accuracy [mm]

Size	35	42	50	63	80
a	0.020	0.020	0.020	0.025	0.025
b	0.012	0.012	0.014	0.016	0.016
c	0.016	0.020	0.024	0.024	0.024

WPU-□-□-CDH

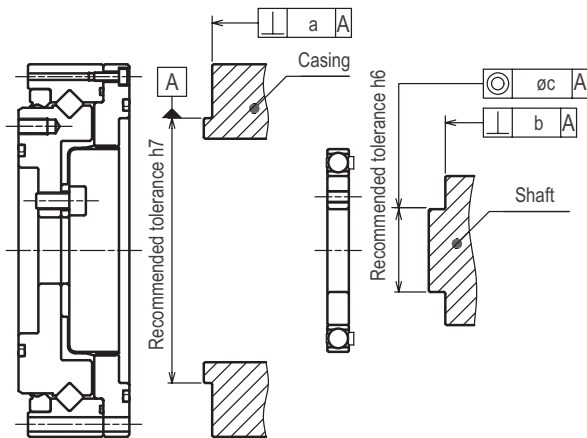

Installation accuracy [mm]

Size	35	42	50	63	80
a	0.020	0.020	0.020	0.025	0.025
b	0.012	0.012	0.014	0.016	0.016
c	0.016	0.020	0.024	0.024	0.024

WPS-□-□-SD

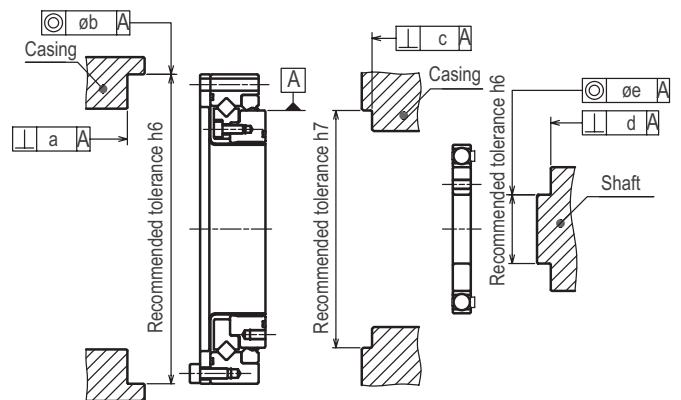

Installation accuracy [mm]

Size	35	42	50	63	80
a	0.020	0.020	0.020	0.025	0.025
b	0.020	0.020	0.020	0.025	0.025
c	0.020	0.020	0.020	0.025	0.025
d	0.012	0.012	0.014	0.016	0.016
e	0.016	0.020	0.024	0.024	0.024

Transmitting Torque

Bolting

Please refer to the table below for the bolt tightening torque.

Tightening torque for bolts

Bolt size	M3	M4	M5	M6	M8	M10
Tightening torque [Nm]	1.9	4.3	8.7	15	36	71

Recommended bolt: Strength rating above 12.9

Bolt specifications and transmitting torque (Closed Type, Unit)

WPU-□-□-CD: Output flange attachment

Size	35	42	50	63	80
Bolt size	M3	M5	M6	M8	M8
Bolt count	10	8	8	8	10
Bolt PCD [mm]	25	27	34	42	57
Tightening torque [Nm]	1.9	8.7	15	36	36
Transmitting torque [Nm]	58	141	252	566	960

WPU-□-□-CD: Internal gear attachment

Size	35	42	50	63	80
Bolt size	M3	M3	M3	M3	M4
Bolt count	6	10	12	18	18
Bolt PCD [mm]	49	56	64	79	104
Tightening torque [Nm]	1.9	1.9	1.9	1.9	4.3
Transmitting torque [Nm]	68	130	178	330	757

WPU-□-□-CDH: Output flange attachment

Size	35	42	50	63	80
Bolt size	M3	M3	M3	M4	M5
Bolt count	6	8	8	10	10
Bolt PCD [mm]	64	74	84	102	132
Tightening torque [Nm]	1.9	1.9	1.9	4.3	8.7
Transmitting torque [Nm]	89	137	156	412	864

WPU-□-□-CDH: Internal gear attachment

Size	35	42	50	63	80
Bolt size	M3	M3	M3	M4	M5
Bolt count	6	8	8	10	10
Bolt PCD [mm]	64	74	84	102	132
Tightening torque [Nm]	1.9	1.9	1.9	4.3	8.7
Transmitting torque [Nm]	89	137	156	412	864

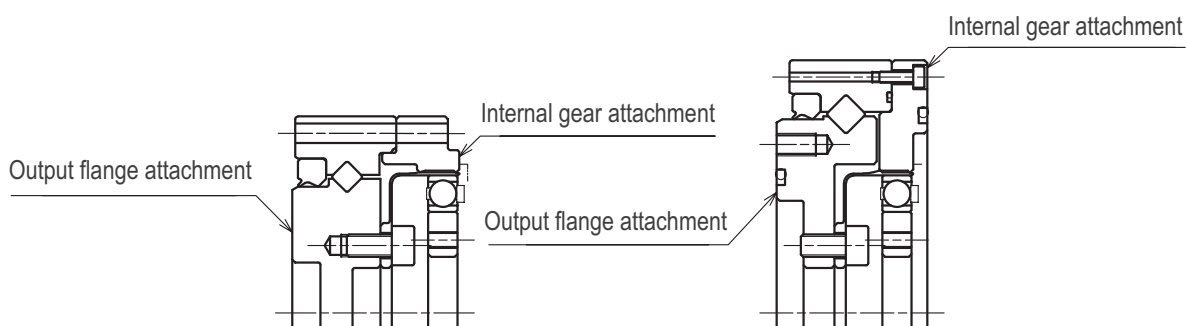

Transmitting Torque

Bolt specifications and transmitting torque (Closed type, Component)

Flex gear attachment

Size	35	42	50	63	80
Bolt size	M3	M4	M4	M5	M6
Bolt count	8	8	8	8	10
Bolt PCD [mm]	17	19.5	24	30	41
Tightening torque [Nm]	1.9	4.3	4.3	8.7	15
Transmitting torque [Nm]	32	63	78	157	380

Internal gear attachment

Size	35	42	50	63	80
Bolt size	M3	M3	M3	M3	M4
Bolt count	6	8	12	12	12
Bolt PCD [mm]	44	54	62	75	100
Tightening torque [Nm]	1.9	1.9	1.9	1.9	4.3
Transmitting torque [Nm]	61	100	172	209	485

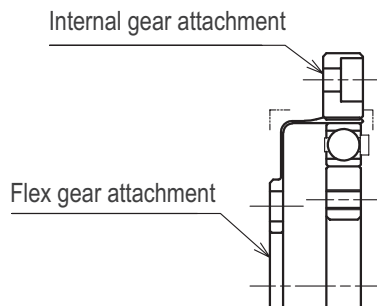

Bolt specifications and transmitting torque (Open type)

Flex gear attachment

Size	35	42	50	63	80
Bolt size	M3	M3	M3	M4	M5
Bolt count	8	12	12	12	12
Bolt PCD [mm]	64	74	84	102	132
Tightening torque [Nm]	1.9	1.9	1.9	4.3	8.7
Transmitting torque [Nm]	119	206	234	495	1037

Internal gear attachment

Size	35	42	50	63	80
Bolt size	M3	M3	M3	M4	M5
Bolt count	8	12	12	12	12
Bolt PCD [mm]	43	52	61.4	76	99
Tightening torque [Nm]	1.9	1.9	1.9	4.3	8.7
Transmitting torque [Nm]	80	145	171	369	778

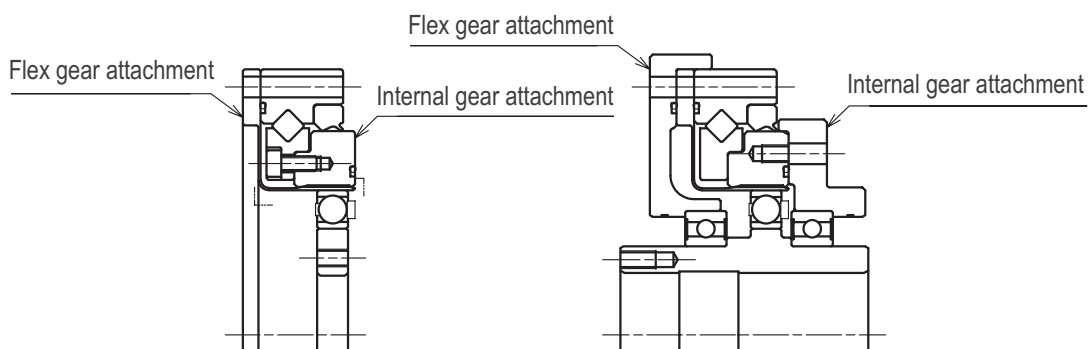

Installation and Assembly Instructions

WPC-□-□-C □

Shaft installation instruction

Please design the support structure for input shaft and output shaft so that both radial and axial loads are supported. (Diagram below shows an example)

Inside thrust load has an effect on the cam. Secure cam from possible axial movement.

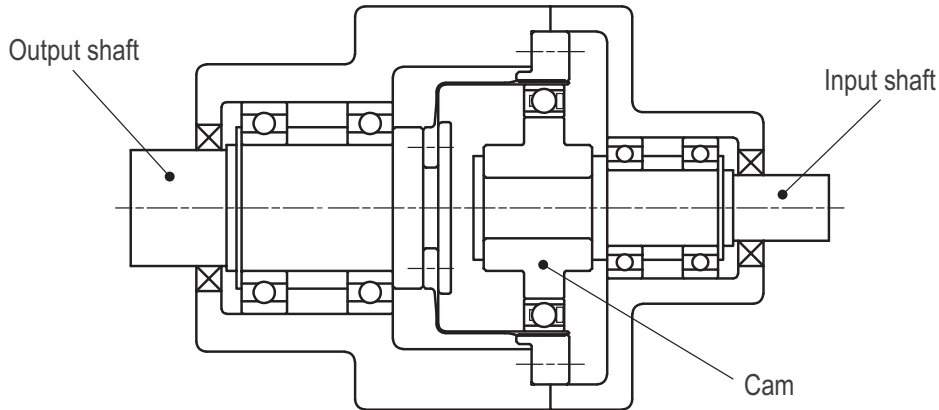

Warm-up run

After assembly, "Warm-up run" is necessary before run with load / torque. The purpose is to coat the Flex gear and Internal gear surface evenly with enough grease in order to meet the load / torque performance.

Condition example

- Load - No load
- Input rotation speed - Start slowly from 1,000r/min or less, then accelerate up to 3,000r/min
- Test time - About 1 hour
- Output rotation angle - As large as possible

Reducer Model / Specifications	Dimensions	Life Estimation (Elastic Bearing)	Life Estimation (Main Bearing)	Maximum Load at Input Shaft	Lubricant Information	Attachment Fixture Requirement Info	Transmitting Torque	Installation & Assembly	Characteristics Data
--------------------------------	------------	-----------------------------------	--------------------------------	-----------------------------	-----------------------	-------------------------------------	---------------------	-------------------------	----------------------

Characteristics Data

Transmission angular accuracy

What is Transmission Angular Accuracy?

It is the difference between the measured output rotation angle and the theoretical angle, while input shaft is rotated with no load.

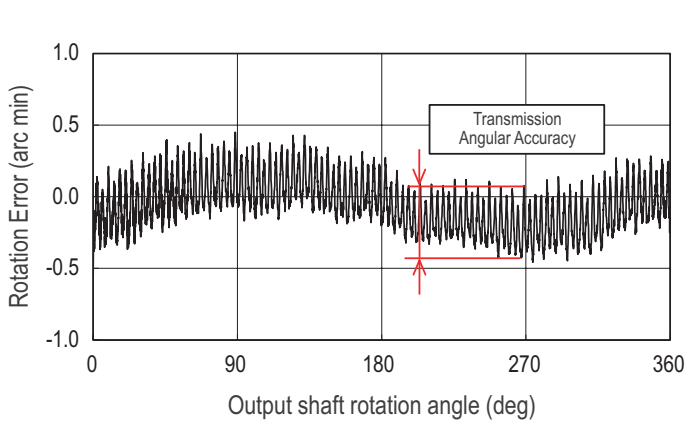

[arc min]

Ratio	Size				
	35	42	50	63	80
50	2.0	2.0	1.5	1.0	1.0
80	1.5	1.5	1.0	1.0	1.0
100	1.5	1.5	1.0	1.0	1.0
120	-	1.5	1.0	1.0	1.0

Table values are reference values.

Hysteresis loss

What is Hysteresis Loss?

When torque load is applied at the output shaft in alternate direction repeatedly with input shaft fixed, there is residual twisting angle when torque is back to zero.

In this context, hysteresis loss is the difference in the forward and backward twisting angle

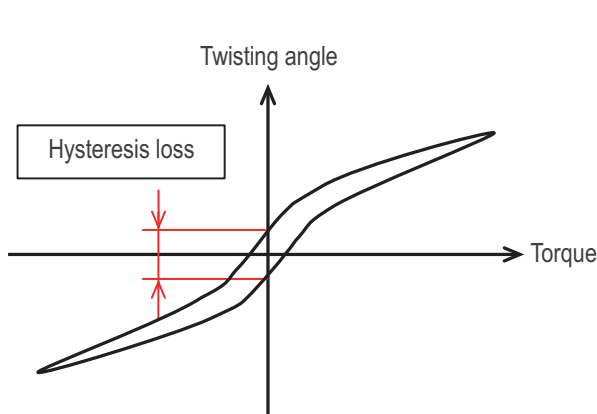

[arc min]

Ratio	Size				
	35	42	50	63	80
50	2.0	2.0	2.0	2.0	2.0
80	1.5	1.5	1.0	1.0	1.0
100	1.5	1.5	1.0	1.0	1.0
120	-	1.5	1.0	1.0	1.0

Table values are reference values.

Characteristics Data

Maximum backlash

What is Maximum Backlash?

In this context, maximum backlash is the output backlash for spline type input shaft. (Backlash is zero for rigid type input, because gear engagement backlash is zero.)

[arc min]

Ratio	Size				
	35	42	50	63	80
50	27	27	18	16	16
80	17	17	11	10	10
100	13	13	9	8	8
120	-	11	7	7	7

Stiffness (Closed type, Unit)

What is Stiffness?

In this context, stiffness is the output shaft twisting angle and the spring coefficient, while torque load is applied to the output shaft with input side fixed.

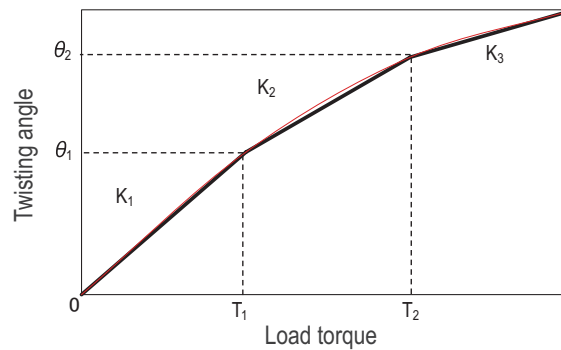

K1... Spring coefficient at 0 ~ T₁ torque
 K2... Spring coefficient at T₁ ~ T₂ torque
 K3... Spring coefficient at T₂ ~ torque

Ratio	Item	Unit	Size				
			35	42	50	63	80
-	T ₁	Nm	2	3.9	7	14	29
-	T ₂	Nm	6.9	12	25	48	108
50	K ₁	× 10 ⁴ Nm/rad	0.39	0.66	1.1	2.2	4.6
	K ₂	× 10 ⁴ Nm/rad	0.47	0.75	1.4	2.6	5.1
	K ₃	× 10 ⁴ Nm/rad	0.52	0.82	1.4	2.7	5.6
	θ ₁	arcmin	1.7	2.0	2.2	2.2	2.2
	θ ₂	arcmin	5.0	5.5	6.3	6.4	7.2
80 100 120	K ₁	× 10 ⁴ Nm/rad	0.44	0.86	1.6	2.9	6.2
	K ₂	× 10 ⁴ Nm/rad	0.60	1.0	1.9	3.2	6.5
	K ₃	× 10 ⁴ Nm/rad	0.72	1.0	1.9	3.1	6.5
	θ ₁	arcmin	1.6	1.6	1.5	1.7	1.6
	θ ₂	arcmin	4.0	4.1	4.6	5.2	5.7

Average value shown in the table.

Characteristics Data

Starting torque (Closed type, Unit)

What is Starting Torque?

Input torque needed for input side to start rotating (no load, ambient temperature: 25°C).

[cNm]

Ratio	Size				
	35	42	50	63	80
50	7.0	11	14	17	26
80	6.8	9.5	13	24	26
100	6.4	9.4	11	14	20
120	-	8.1	9.3	14	20

*1 For reference only. Torque value may vary depending on the condition.

*2 Charts does not show effects due to rotation resistance of bearings and oil seals on the input side.

Output starting torque (Closed type, Unit)

What is Output Starting Torque?

Output torque needed for output side to start rotating (no load, ambient temperature: 25°C)

[Nm]

Ratio	Size				
	35	42	50	63	80
50	1.2	3.6	4.4	5.8	13
80	1.6	3.9	7.2	13	26
100	1.7	5.7	8.6	9.4	23
120	-	4.2	8.1	10	30

*1 For reference only. Torque value may vary depending on the condition.

*2 Charts does not show effects due to rotation resistance of bearings and oil seals on the input side.

No-load running torque (Closed type, Unit)

What is No-load Running Torque?

Input torque needed to keep it running with no load (average value, ambient temperature: 25°C)

[cNm]

Ratio	Input Rotation Speed	Size				
		35	42	50	63	80
50	500r/min	3.4	7.5	9.2	17	35
	1000r/min	4.3	8.2	11	18	37
	2000r/min	5.0	8.5	13	18	39
	3500r/min	5.4	11	14	22	38
80	500r/min	3.2	7.6	10	20	35
	1000r/min	4.0	8.7	12	21	38
	2000r/min	4.8	8.9	14	22	39
	3500r/min	5.2	11	14	24	38
100	500r/min	3.2	7.1	11	21	36
	1000r/min	4.0	8.2	13	23	39
	2000r/min	4.7	8.4	14	24	39
	3500r/min	5.1	9.7	14	25	38
120	500r/min	-	6.7	9.8	23	40
	1000r/min	-	8.1	12	24	41
	2000r/min	-	8.4	13	26	41
	3500r/min	-	8.4	13	26	39

*1 For reference only. Torque value may vary depending on the condition.

*2 Charts does not show effects due to rotation resistance of bearings and oil seals on the input side.

Characteristics Data

Efficiency (Closed type, Unit)

- Percentile load (%) is equal to load torque divided by allowable average torque.
- Ambient temperature: 25°C

WPU-35-50

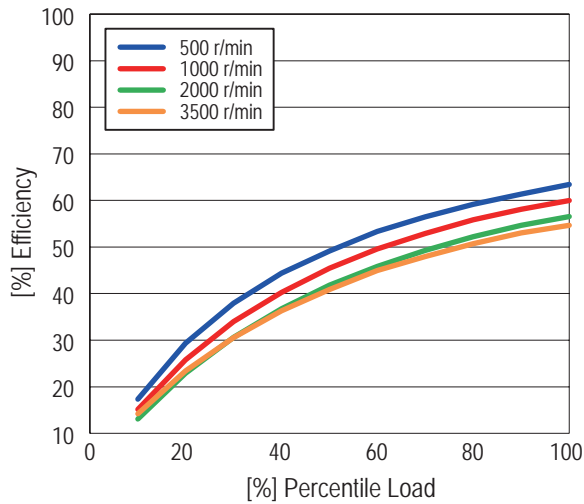

WPU-35-80

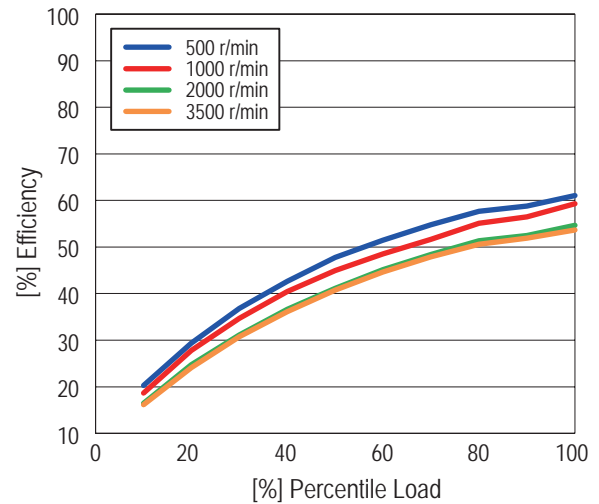

WPU-35-100

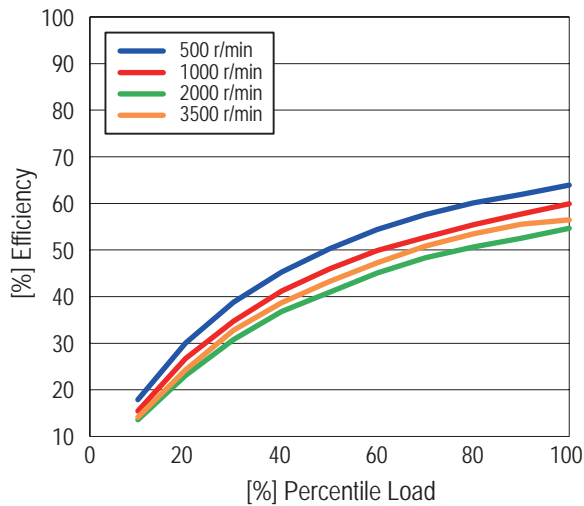

*1 These diagrams represent the average value of the actual measurement.

*2 Charts does not show effects due to rotation resistance of bearings and oil seals on the input side.

Reducer Model / Specifications	Dimensions	Life Estimation (Elastic Bearing)	Life Estimation (Main Bearing)	Maximum Load at Input Shaft	Lubricant Information	Attachment Fixture Requirement Info	Transmitting Torque	Installation & Assembly	Characteristics Data
--------------------------------	------------	-----------------------------------	--------------------------------	-----------------------------	-----------------------	-------------------------------------	---------------------	-------------------------	----------------------

Characteristics Data

Efficiency (Closed type, Unit)

- Percentile load (%) is equal to load torque divided by allowable average torque.
- Ambient temperature: 25°C

WPU-42-50

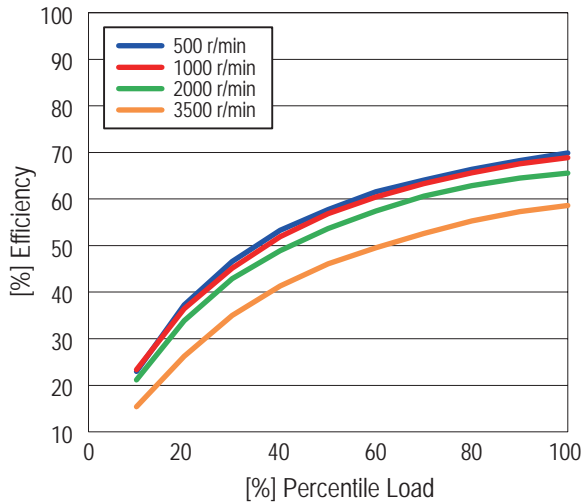

WPU-42-80

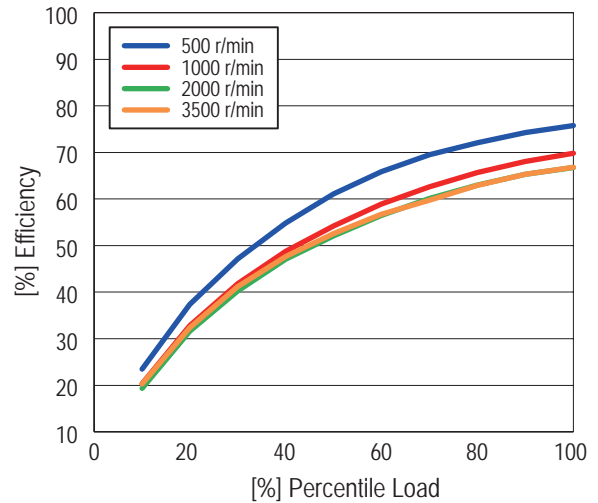

WPU-42-100

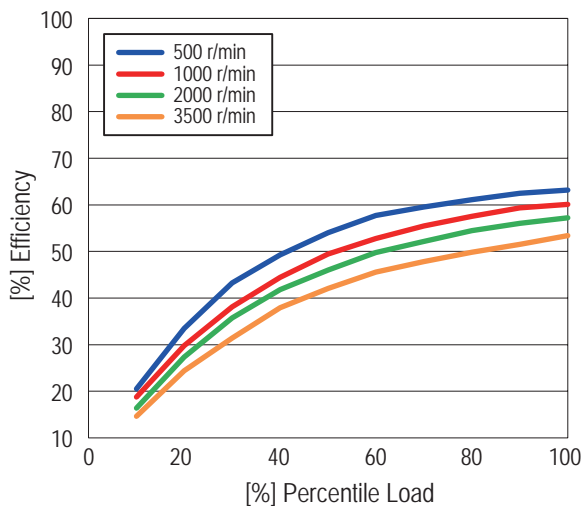

WPU-42-120

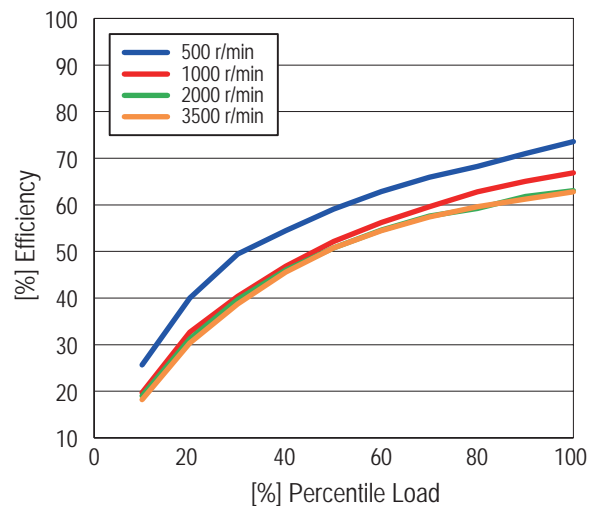

*1 These diagrams represent the average value of the actual measurement.

*2 Charts does not show effects due to rotation resistance of bearings and oil seals on the input side.

Characteristics Data

Efficiency (Closed type, Unit)

- Percentile load (%) is equal to load torque divided by allowable average torque.
- Ambient temperature: 25°C

WPU-50-50

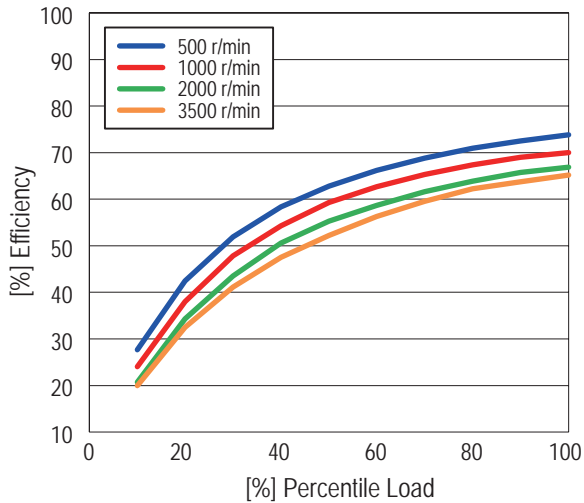

WPU-50-80

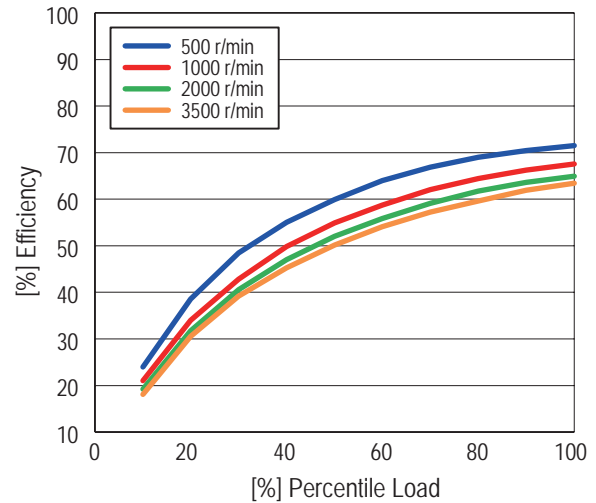

WPU-50-100

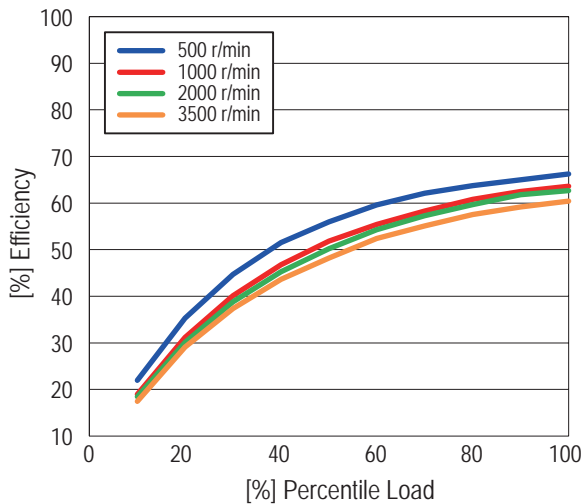

WPU-50-120

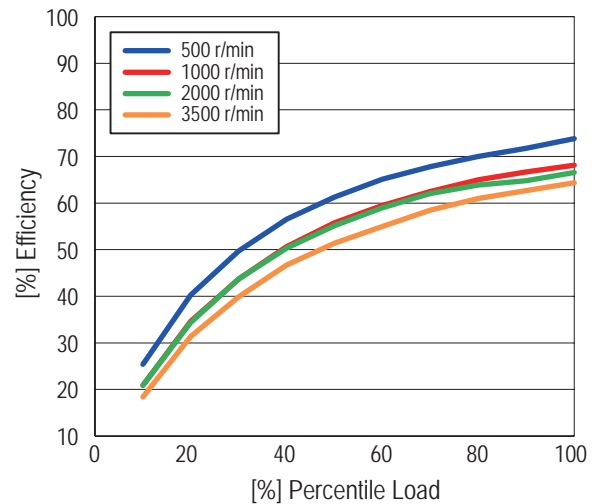

*1 These diagrams represent the average value of the actual measurement.

*2 Charts does not show effects due to rotation resistance of bearings and oil seals on the input side.

Reducer Model/ Specifications
Dimensions
Life Estimation (Elastic Bearing)
Life Estimation (Main Bearing)
Maximum Load at Input Shaft
Lubricant Information
Attachment Fixture Requirement Info
Transmitting Torque
Installation & Assembly
Characteristics Data

Characteristics Data

Efficiency (Closed type, Unit)

- Percentile load (%) is equal to load torque divided by allowable average torque.
- Ambient temperature: 25°C

WPU-63-50

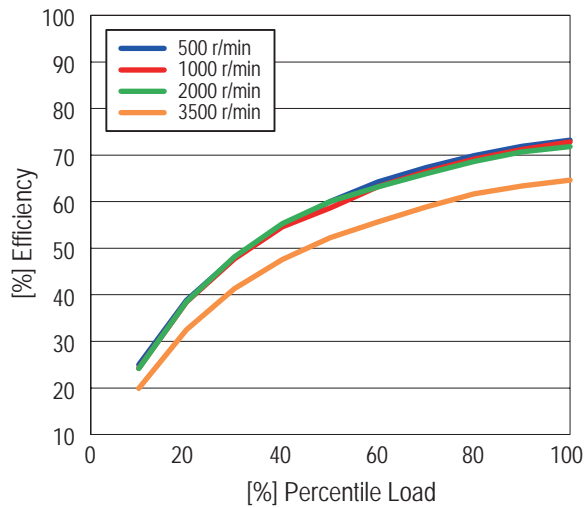

WPU-63-80

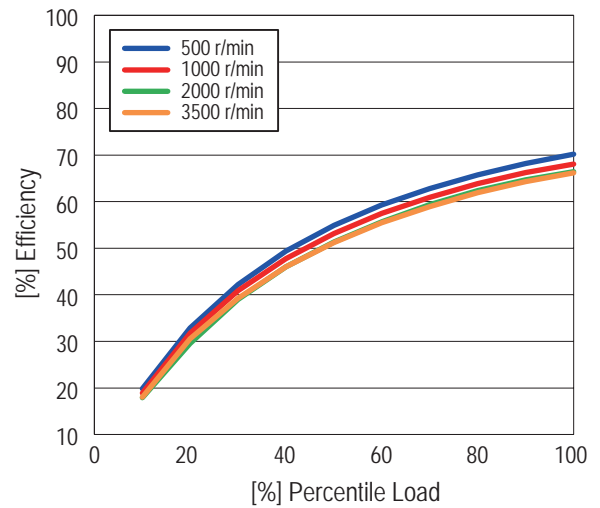

WPU-63-100

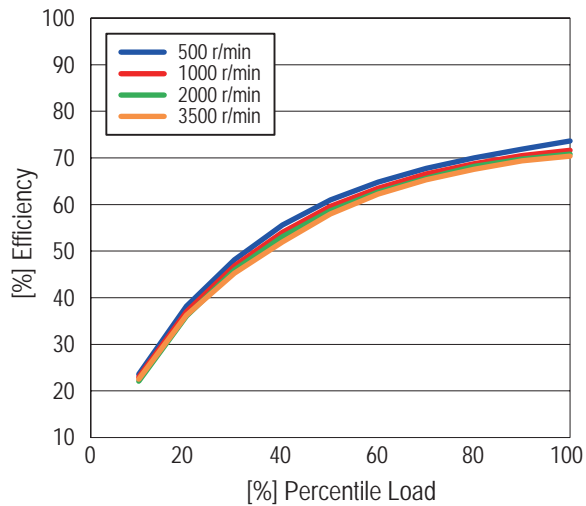

WPU-63-120

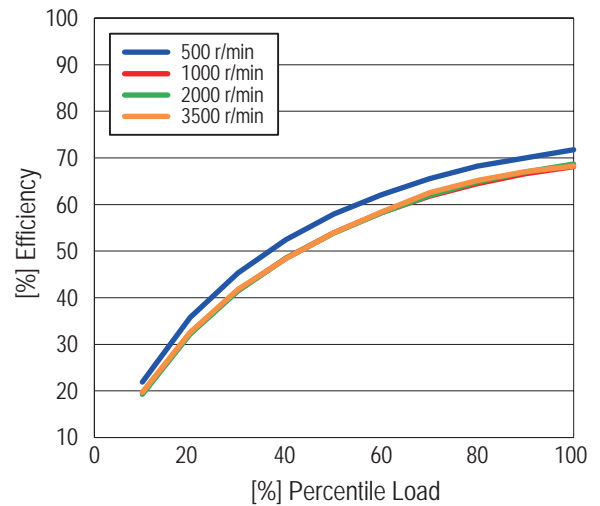

*1 These diagrams represent the average value of the actual measurement.
 *2 Charts does not show effects due to rotation resistance of bearings and oil seals on the input side.

Characteristics Data

Efficiency (Closed type, Unit)

- Percentile load (%) is equal to load torque divided by allowable average torque.
- Ambient temperature: 25°C

WPU-80-50

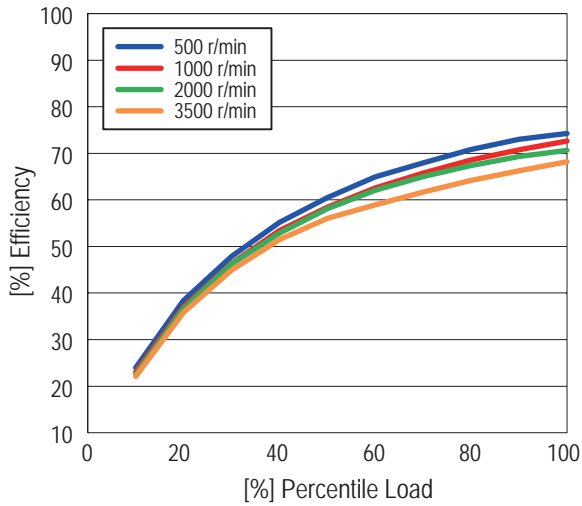

WPU-80-80

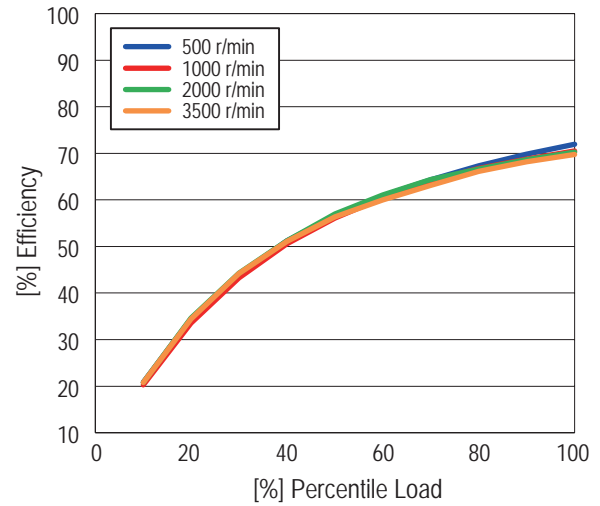

WPU-80-100

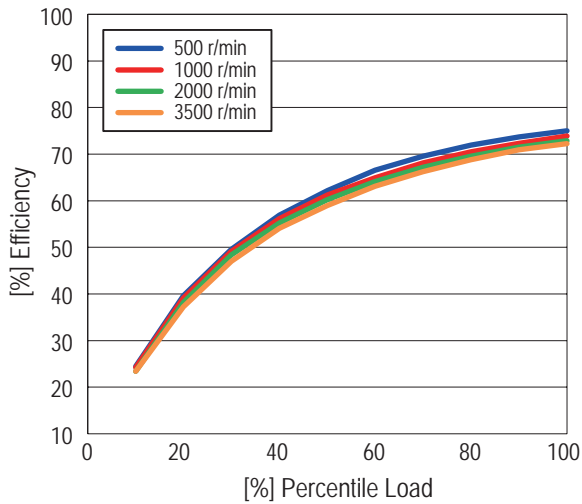

WPU-80-120

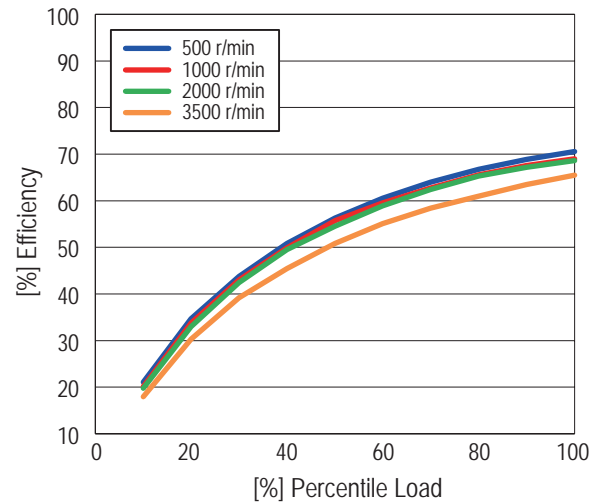

*1 These diagrams represent the average value of the actual measurement.

*2 Charts does not show effects due to rotation resistance of bearings and oil seals on the input side.

Reducer Model/ Specifications
Dimensions
Life Estimation (Elastic Bearing)
Life Estimation (Main Bearing)
Maximum Load at Input Shaft
Lubricant Information
Attachment Fixture Requirement Info
Transmitting Torque
Installation & Assembly
Characteristics Data

Reducer Model Nomenclature

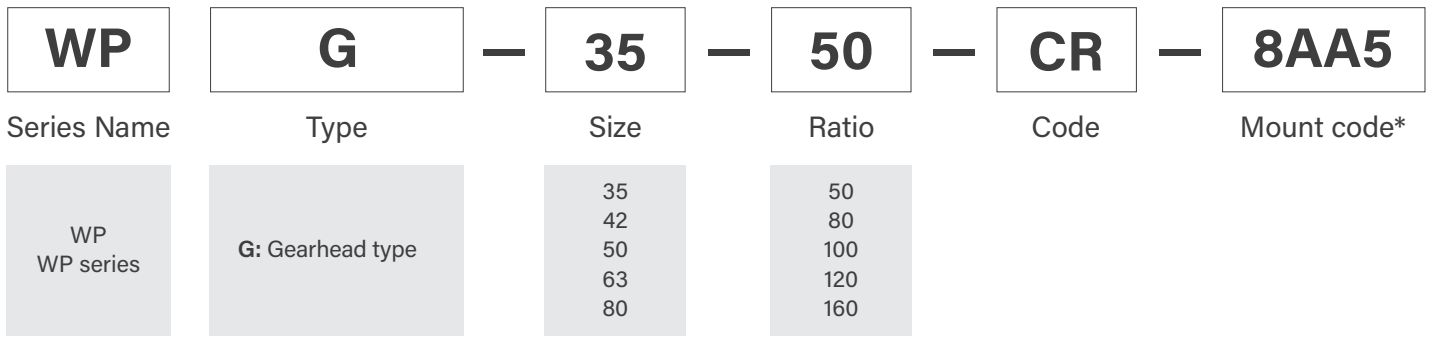

* Mount code varies depending on the motor selection. Please refer to the 'Reducer Selection Tool' found on our website for further details, or alternatively please contact us for more information.

Ratio Matrix Availability

Frame Size	Reduction Ratio				
	50	80	100	120	160
35					
42					
50					
63					
80					

Reducer Specifications

Size	Ratio R*1	Nominal Output Torque *2	Maximum Output Torque *3	Nominal Input Speed *4	Maximum Input Speed *5	Life *6
		[Nm]	[Nm]	[r/min]	[r/min]	[hours]
35	50	7	23	3000	8500	10000
	80	10	30			
	100	10	36			
42	50	21	44	3000	7300	
	80	29	56			
	100	31	70			
	120	31	70			
50	50	33	73	3000	6500	
	80	44	96			
	100	52	107			
	120	52	113			
	160	52	120			
63	50	51	127	3000	5600	
	80	82	178			
	100	87	204			
	120	87	217			
	160	87	229			
80	50	99	281	3000	4800	
	80	153	395			
	100	178	433			
	120	178	459			
	160	178	484			

*1 Reduction ratio is to be calculated by the formula in the previous page, using R value in this table.

*2 The maximum allowable value at the input rotation speed of 2000r/min

*3 The maximum torque when starting and stopping.

*4 The maximum average input speed.

*5 The maximum input speed.

*6 The life time at the input rotation speed of 2000 r/min and nominal output torque.

Dimensions

Gearhead Type

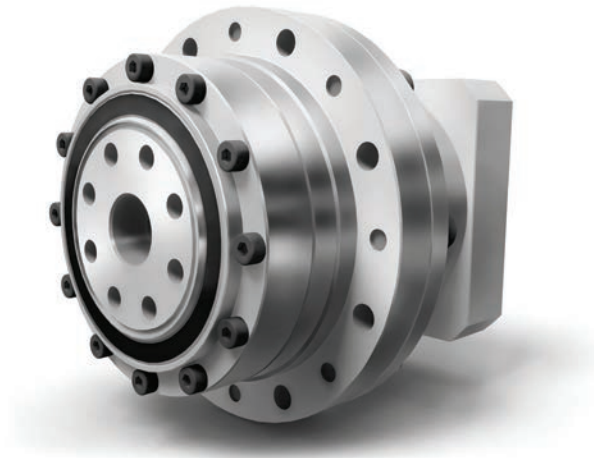
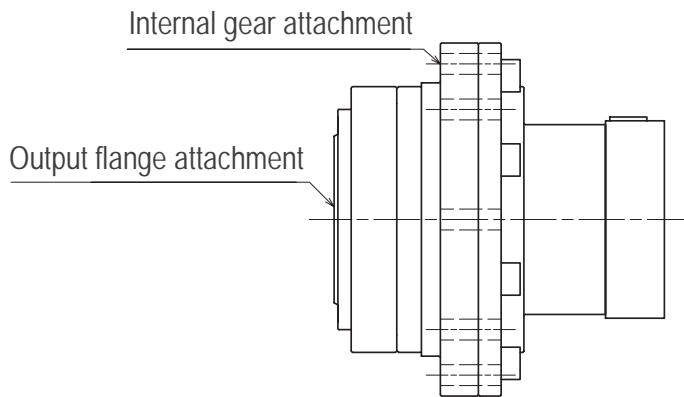

Precautions

When attaching equipment parts to the output flange, use the supplied O-rings or implement your own grease leakage prevention measures.

WPG-35-□-CR-8□ (Input shaft diameter ≤ 8)

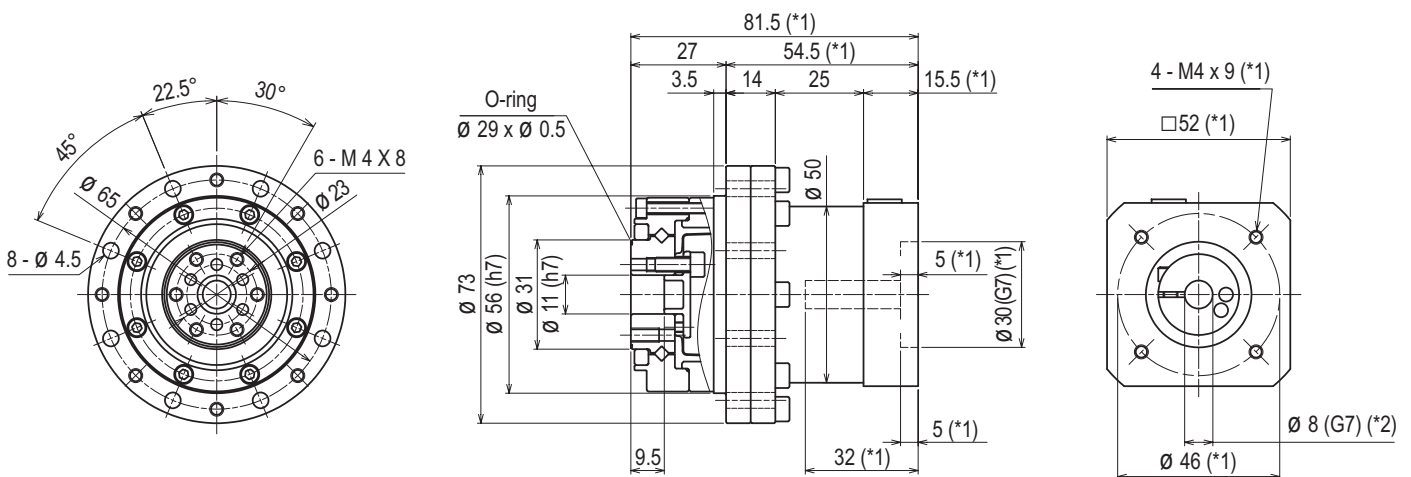

*1 The length depends on the motor.

*2 Bushing will be inserted to adapt to motor shaft.

Reducer Model/ Specifications	Dimensions	Life Estimation (Elastic Bearing)	Life Estimation (Main Bearing)	Lubricant Information	Transmitting Torque
----------------------------------	------------	--------------------------------------	-----------------------------------	-----------------------	---------------------

Dimensions

WPG-42-□-CR-8□ (Input shaft diameter ≤ 8)

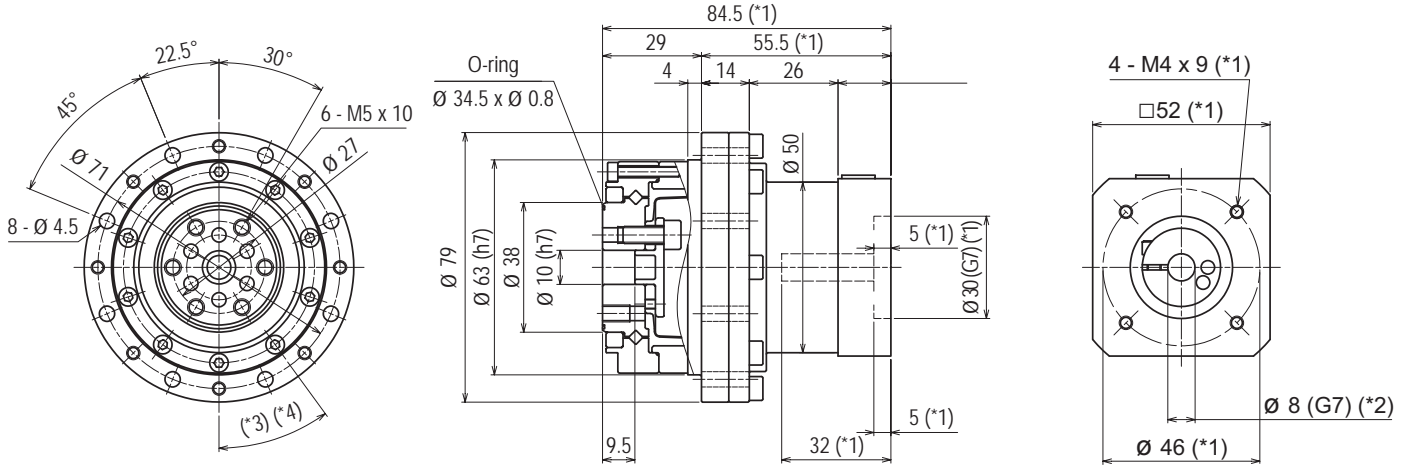

- *1 The length depends on the motor.
- *2 Bushing will be inserted to adapt to motor shaft.
- *3 The actual placement may differ.
- *4 These bolts are for reducer assembly purposes and do not affect installation.

WPG-42-□-CR-14□ (8 < Input shaft diameter ≤ 14)

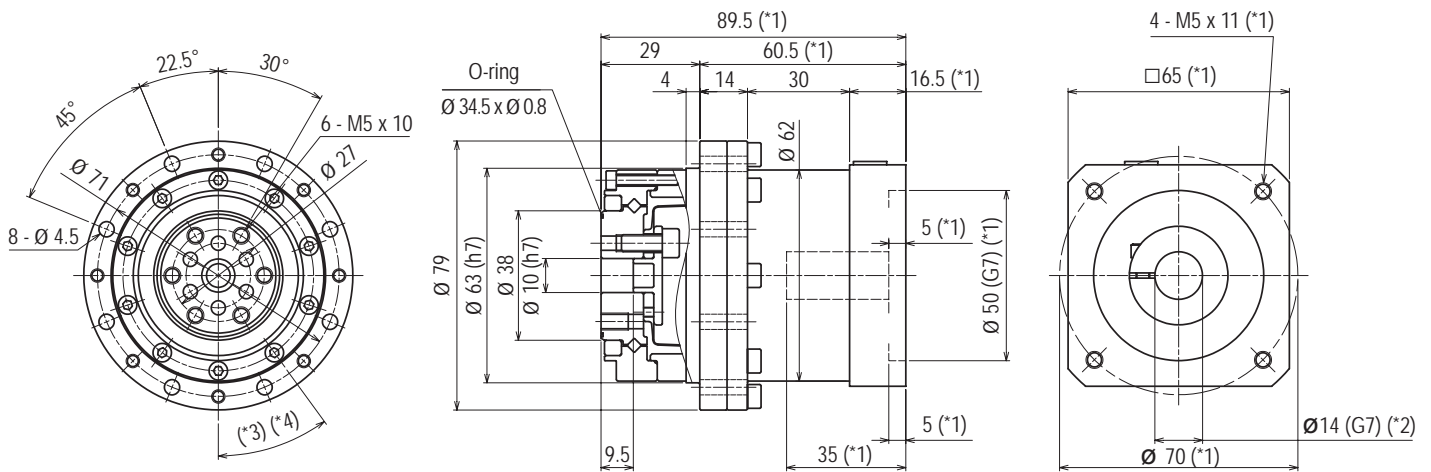

- *1 The length depends on the motor.
- *2 Bushing will be inserted to adapt to motor shaft.
- *3 The actual placement may differ.
- *4 These bolts are for reducer assembly purposes and do not affect installation.

Dimensions

WPG-50-□-CR-8□ (Input shaft diameter ≤ 8)

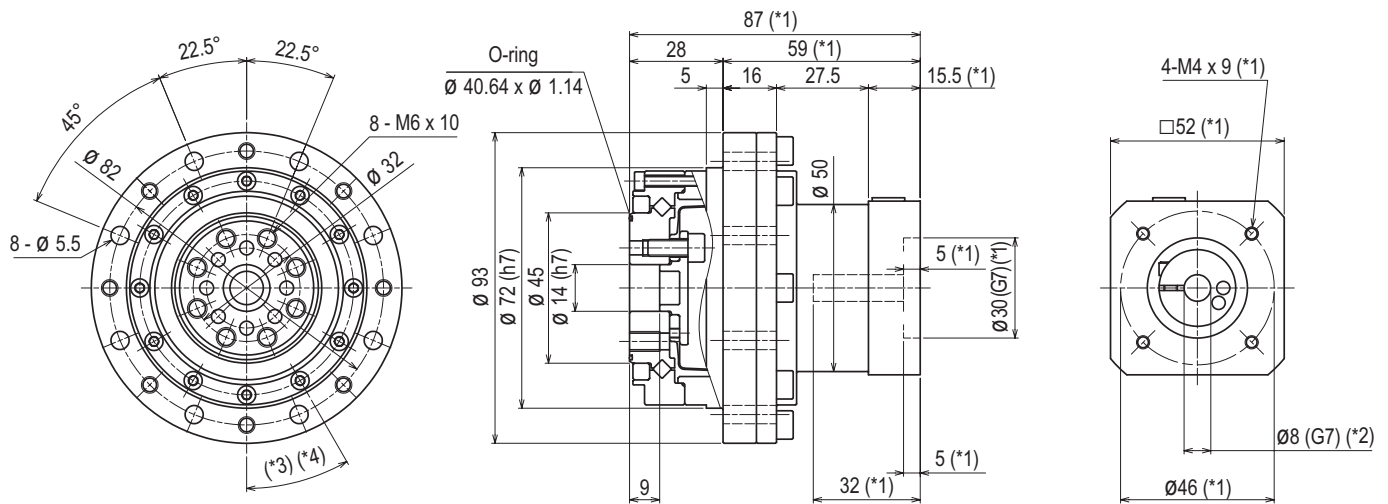

- *1 The length depends on the motor.
- *2 Bushing will be inserted to adapt to motor shaft.
- *3 The actual placement may differ.
- *4 These bolts are for reducer assembly purposes and do not affect installation.

WPG-50-□-CR-14□ (8 < Input shaft diameter ≤ 14)

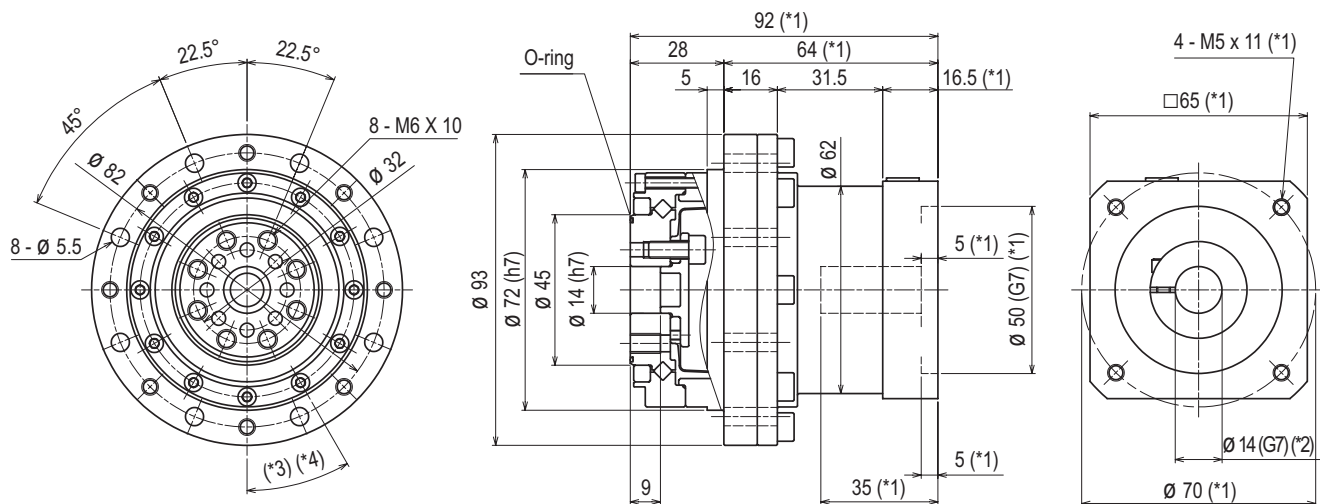

- *1 The length depends on the motor.
- *2 Bushing will be inserted to adapt to motor shaft.
- *3 The actual placement may differ.
- *4 These bolts are for reducer assembly purposes and do not affect installation.

Reducer Model/ Specifications	Dimensions	Life Estimation (Elastic Bearing)	Life Estimation (Main Bearing)	Lubricant Information	Transmitting Torque
----------------------------------	------------	--------------------------------------	-----------------------------------	-----------------------	---------------------

Dimensions

WPG-63-□-CR-14□ (8 < Input shaft diameter ≤ 14)

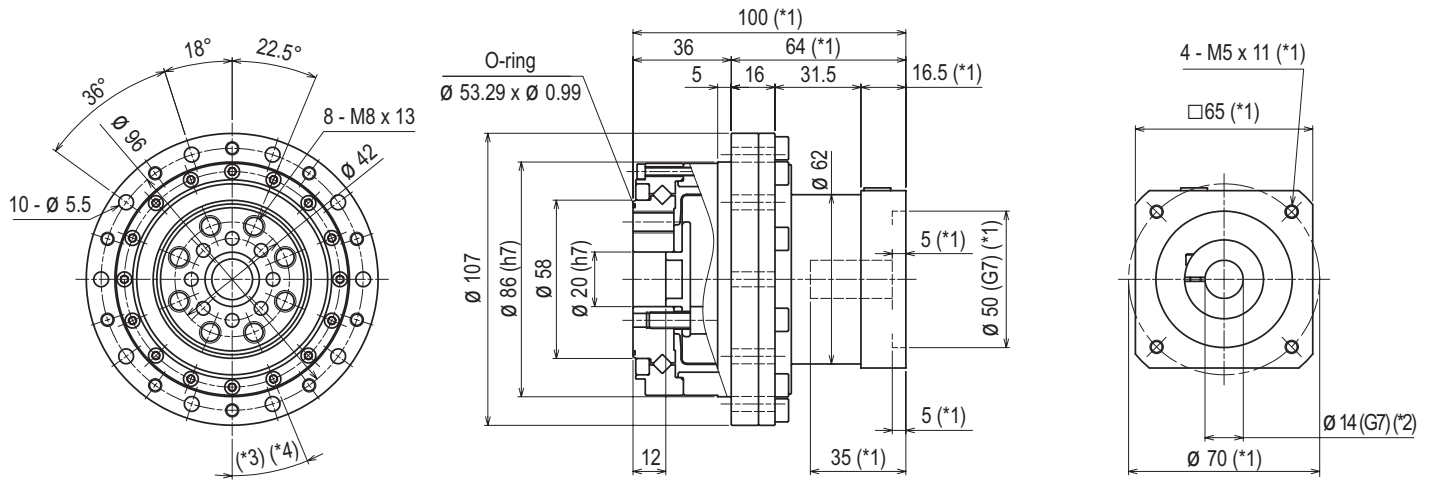

- *1 The length depends on the motor.
- *2 Bushing will be inserted to adapt to motor shaft.
- *3 The actual placement may differ.
- *4 These bolts are for reducer assembly purposes and do not affect installation.

WPG-63-□-CR-19□ (14 < Input shaft diameter ≤ 19)

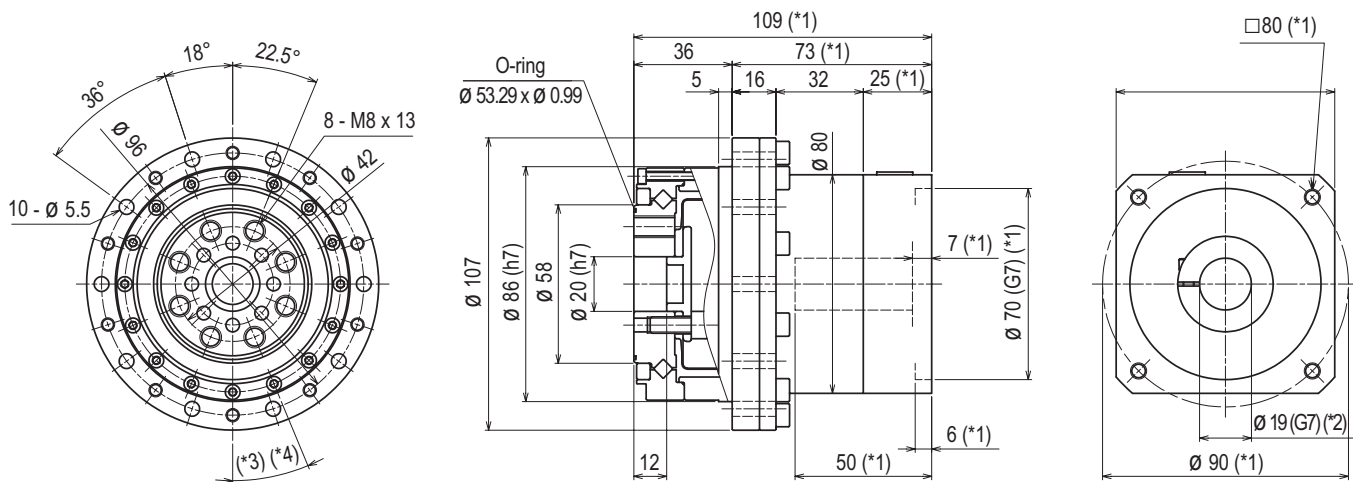

- *1 The length depends on the motor.
- *2 Bushing will be inserted to adapt to motor shaft.
- *3 The actual placement may differ.
- *4 These bolts are for reducer assembly purposes and do not affect installation.

Dimensions

WPG-80-□-CR-14□ (8 < Input shaft diameter ≤ 14)

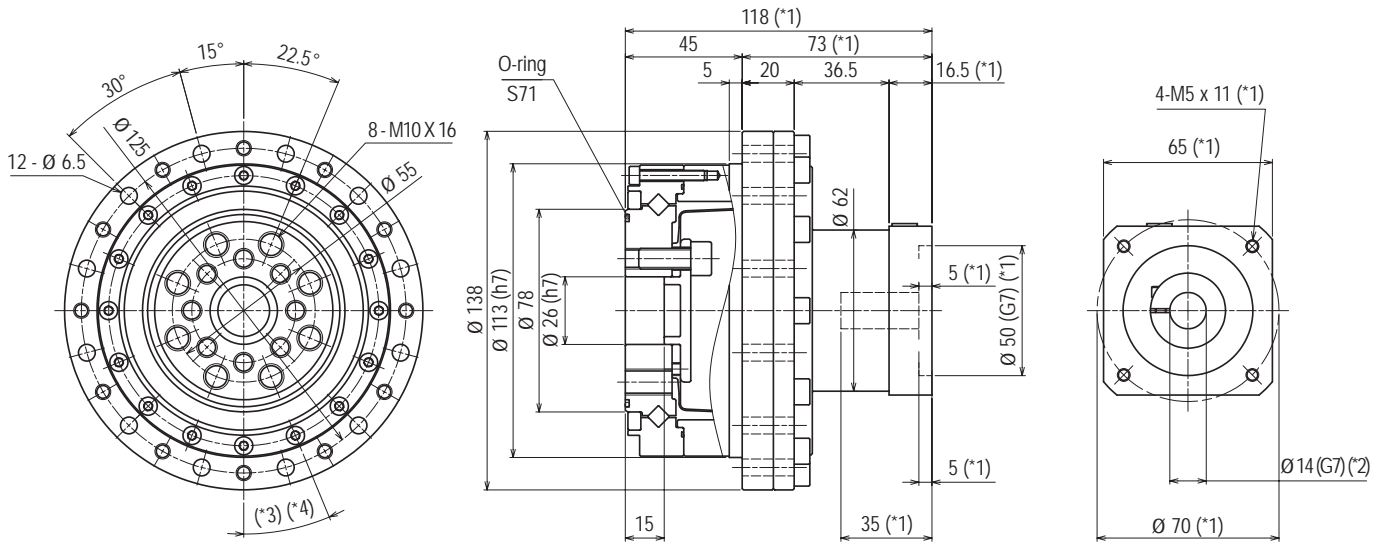

- *1 The length depends on the motor.
- *2 Bushing will be inserted to adapt to motor shaft.
- *3 The actual placement may differ.
- *4 These bolts are for reducer assembly purposes and do not affect installation.

WPG-80-□-CR-19□ (14 < Input shaft diameter ≤ 19)

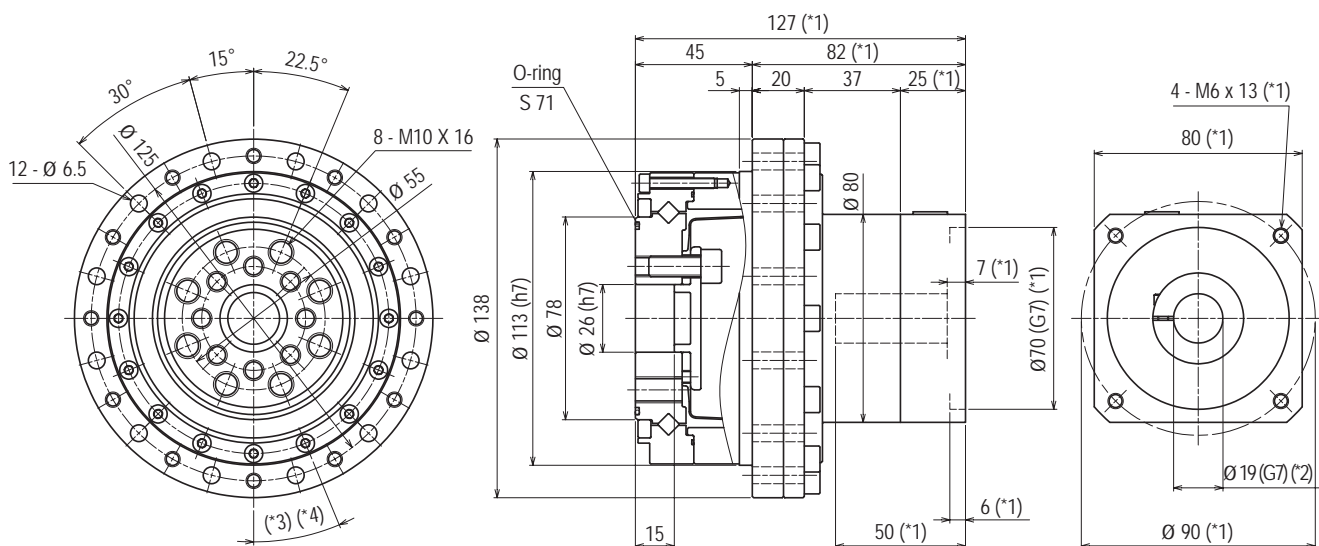

- *1 The length depends on the motor.
- *2 Bushing will be inserted to adapt to motor shaft.
- *3 The actual placement may differ.
- *4 These bolts are for reducer assembly purposes and do not affect installation.

Reducer Model/ Specifications	Dimensions	Life Estimation (Elastic Bearing)	Life Estimation (Main Bearing)	Lubricant Information	Transmitting Torque
----------------------------------	------------	--------------------------------------	-----------------------------------	-----------------------	---------------------

Life Estimation (Elastic Bearing)

Life estimation (Main bearing)

* Please check the formula on page 11

Life Estimation (Main Bearing)

Main bearing specification (Cross roller bearing)

Series	Size	Pitch Circle Diameter of the Bearing Rollers	Offset	Basic Dynamic Load Rating	Basic Static Load Rating	Allowable Moment	Moment Rigidity
		Dm	L	C	Co	Mal	Km
		m	m	N	N	Nm	$\times 10^4$ Nm/rad
WPG-□-□-CR	35	0.035	0.010	4700	6070	41	4.38
	42	0.043	0.010	5290	7550	64	7.75
	50	0.050	0.010	5780	9000	91	12.8
	63	0.062	0.012	9600	15100	156	24.2
	80	0.080	0.013	15000	25000	313	53.9

Operation cycle example

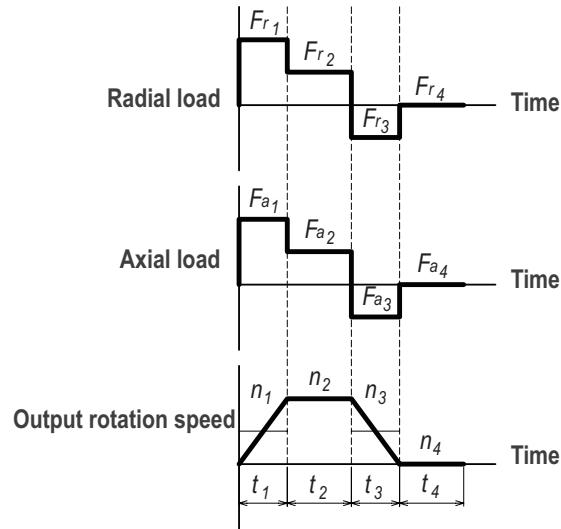

External load

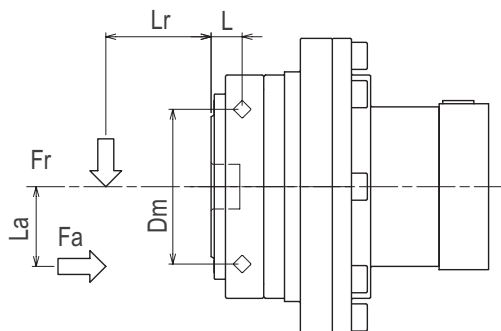

* Please check the formula on page 13

Lubricant Information

Grease

Sumiplex SFB No.1 (SUMICO LUBRICANT CO., LTD.)

Operating temperature range: 0-40°C (ambient temperature)

Grease application

- Grease is already sealed inside the reducer at the factory, so it can be used as-is.

Transmitting Torque

Bolting

Please refer to the table below for the bolt tightening torque.

Please be noted that the transmittable torque varies depending on the bolt count (different between CF and CN) and tightening torque.

Tightening torque for bolts

Bolt size	M3	M4	M5	M6	M8	M10
Tightening torque [Nm]	1.9	4.3	8.7	15	36	71

Recommended bolt: Strength rating above 12.9

Bolt specifications and Transmitting torque

Output flange attachment

Size	35	42	50	63	80
Bolt size	M4	M5	M6	M8	M10
Bolt count	6	6	8	8	8
Bolt PCD [mm]	23	27	32	42	55
Tightening torque [Nm]	4.3	8.7	15	36	71
Transmitting torque [Nm]	56	106	238	566	1177

Internal gear attachment (CR)

Size	35	42	50	63	80
Bolt size	M4	M4	M5	M5	M6
Bolt count	8	8	8	10	12
Bolt PCD [mm]	65	71	82	96	125
Tightening torque [Nm]	4.3	4.3	8.7	8.7	15
Transmitting torque [Nm]	210	230	430	629	1392

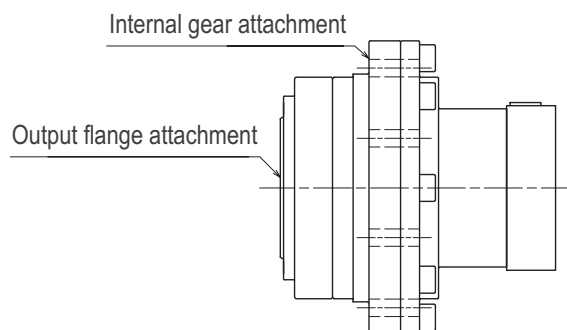

Customer Service and Support

Distinction in Service and Support

Nidec Drive Technology Corporation has invested heavily in building a global customer service and application support network that will meet the evolving needs of our customers. By leveraging our global infrastructure, our OEM customers maintain their competitiveness and profitability at home while able to expand into emerging markets abroad without any drop-off of service and support.

Nidec DTC pledges that we will continue to expand our service and support network footprint globally, and continuously strive for perfection as a dependable partner to our customers. In this section you will learn about our service and support capabilities that we will leverage in order to provide you peace of mind.

Online and Phone Support

Resolve your technical issues quickly and accurately, without disrupting your business. When you do business with Nidec Drive Technology, your company and your customers have immediate access to our global network of support centers and resources. Whether you need help designing, installing, and maintaining equipment or diagnosing an operating issue, Nidec DTC will deliver the tools and information that you need in order to insure that your equipment is running to perfection.

Contact your local sales office for immediate support either over the phone or in the field. All customer accounts in North America have a dedicated Technical Support Engineer, knowledgeable about your business, on-standby ready to support you and your customers. If you do not know who to contact, please call our 1-800 number in order to get properly directed to the right person for help.

For online support, please visit our website in order to download any drawings, instruction manuals, or technical performance specifications that you require. All catalogs and brochures are easily downloadable on the website. If you prefer to inquire about an issue or for more information, please do not hesitate to submit your request online or email us at the address listed below.

Training Services

Investing our time in you, so together we build better, more competitive product for your customer. As the industrial world becomes increasingly competitive, new technologies are introduced every year requiring manufacturers to constantly rationalize and update existing designs. As a result, successful manufacturers realize the absolute need for product training.

Nidec DTC has a network of engineers that are factory trained and authorized to provide your workforce solid training on our products and basic power transmission concepts. The main objective of our standard program and materials is to better empower your workforce to size and select gearboxes for any motion control applications. We provide this service at no cost to our customers, because we see the value in building a more knowledgeable customer and helping them more quickly react to equipment design revisions when needed.

Other manufacturers are not as forthcoming with sharing information with their customers, an attempt to hide their higher manufacturing costs or to use unreleased performance data as a "product differentiator." Nidec DTC views their customers as long term partners and trains and shares information freely based on that vision.

Training classes can be conducted online, at any of our sales branches or offices, or at key distributor branches when requested. Nidec DTC can also bring the training session to your facility in order to make better use of your time and costs. A thorough hands-on training seminar can be provided at our North American headquarters in Glendale Heights, where customers can get the opportunity to completely assemble and test our products.

The Nidec DTC training program options provide support for any budget. Our training programs improve your employees' skill and knowledge competencies in the areas of power transmission and motion control while addressing any location, time, travel and productivity constraints. Contact your local sales office today in order to get a product refresher on your calendar.



Nidec Drive Technology Hotline:

Toll-free: (800) 842-1479

Email: ndta.info@nidec.com

Selection Tool Configurator

Nidec Drive Technology's Online Product Configurator makes it easier than ever for engineers to incorporate our products into their drive system design. Our configurator allows our customers to select from wide range of servo motor manufacturer models to ensure flawless fitment with our products. With over 75 motor manufacturers included, there is a good possibility we have a solution ready to go.

In addition to motor sizing, our configurator also allows our customers to select gearheads based on application. These applications include rotary tables, belt conveyors, rack and pinion drives, lifting and lowering devices, ball screws, drive gears, drive carriages and robot joints. After selecting the application template, customers can then input the application load parameters and motion profile. The proper frame size and reduction ratio are then determined, with motor selection as the final last step.

Once sizing is complete, our configurator will then display the full part number, along with gearbox and motor technical specifications. This part number includes the motor mounting adapter, which can be sent directly to our sales support team for pricing & delivery.



Drawings and models are also available in PDF, DXF, IGS and STEP formats, making it simple for machine designers to quickly drop them into machine schematics to check for proper fitment. We have seasoned application engineers standing by to assist with any sizing or selection questions.

<https://www.nidec-drivetechnology.co.jp/selection/all/>

Application Selection

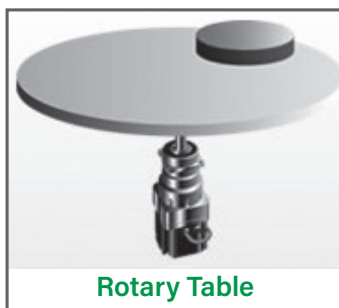

Rotary Table



Belt Conveyor



Rack and Pinion



Lifting & Lowering Device

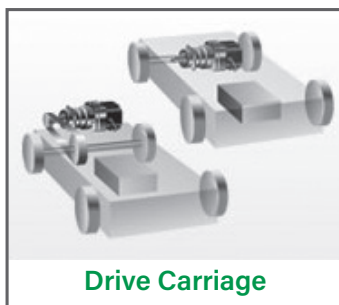

Drive Carriage



Ball Screw



Drive Gears



Robot Joints

nidec-dtc.com

Nidec

NIDEC DRIVE TECHNOLOGY CORPORATION
175 Wall Street, Glendale Heights, IL 60139 USA
Phone: (800) 842-1479 • info@nidec-dtc.com