



Precision Gear Technology Guide



NIDEC DRIVE TECHNOLOGY

Our Company

NIDEC DRIVE TECHNOLOGY CORPORATION (NDT) has established itself as the leading supplier of precision gearing solutions to the industrial automation marketplace. Since 1952, when we introduced the world's first mechanical variable speed drive, NDT has expanded into a diverse manufacturer of high precision power transmission systems for highly dynamic motion control applications. In 1994, NDT was acquired by the NIDEC Corporation and became formally known as NIDEC DRIVE TECHNOLOGY. NDT began to focus on accelerating production volumes as the global market for motion control and mechatronics grew at an accelerated rate. We saw a unique opportunity to supply our customer base with the highest variety of transmission technologies, which brought forward strain wave, index table and worm gear products to complement our existing portfolio of planetary and cycloidal gearheads. The result for our customers was a single source drive solutions supplier.

Today, our company is shipping over 155,000+ gearheads per month out of our manufacturing plants in Kyoto, Philippines, and Shanghai. Our products are used in robotics, machine tools, food packaging, printing, paper converting, material handling, medical, semiconductor and aerospace related systems. Our diverse product portfolio, state-of-the-art equipment, engineering know-how and manufacturing scale allow our customers to compete and expand their businesses globally. NDT has over 2,400 employees strong with a presence across five continents. Our engineering staff, customer support team and distribution partners undergo rigorous product training to ensure the quickest response to our customers' needs. Our aim is to continue to innovate and provide the highest quality, best-in-class products and services for our customer base.



Our Local Capabilities

NIDEC DRIVE TECHNOLOGY services the North American market through our Headquarters and 50,000 sq. ft. assembly facility in Glendale Heights, Illinois. This facility houses our sales, design and application engineering and customer support teams. We assemble over 75% of our products in North America, most of which can ship within 1 week. Motor adapters are readily available for easy mounting to any servomotor manufacturers' models. With over \$3MM in inventory, next day delivery is available for several common models and for emergency replacements for equipment in the field. We are highly flexible and can fulfill custom requirements such as special output shafts dimensions, coatings, lubrication, materials of construction and integrated product assemblies.



Our products are 100% exit-tested to ensure all performance specifications are met, giving our customers security and peace of mind. Each gearbox is inspected for noise, backlash, vibration, no-load running torque, concentricity and input shaft slipping using the latest equipment and methods. Our 5 Year Standard Warranty is our way of demonstrating NDT's commitment to quality and durability over the long term. Local, personal support is a phone call or email away. Each NIDEC DRIVE TECHNOLOGY customer has a dedicated team of customer service and technical support professionals, on-standby to assist with pricing, delivery, sizing, repairs, installation support or other needs. We strive to deliver the highest quality, value and service in the industry.



VR Series Inline Planetary Gearheads





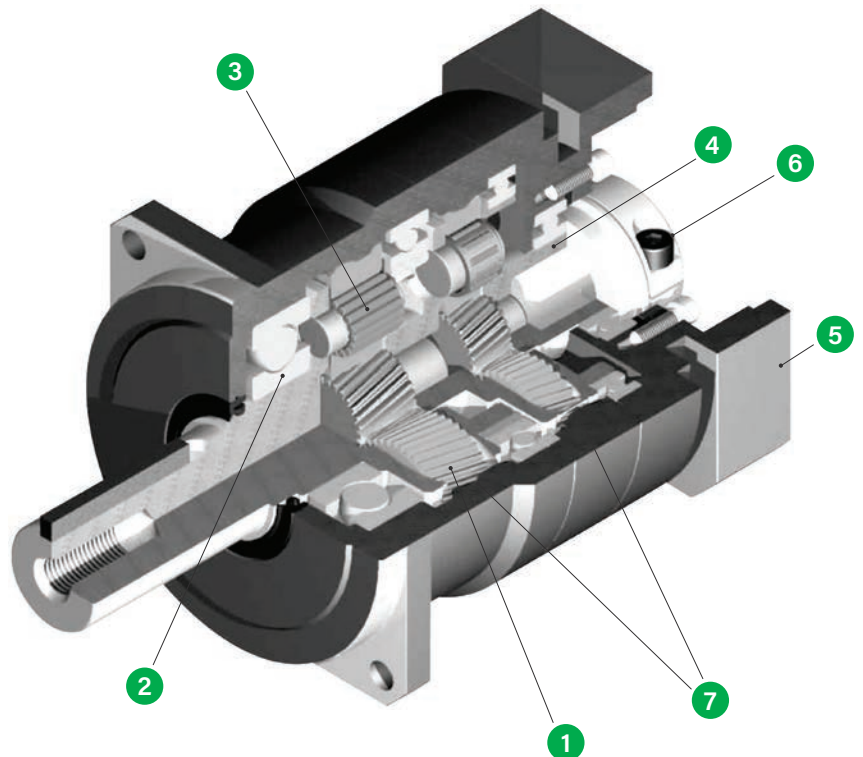

- Exceptional value for mid to high end motion control applications with demanding accuracy requirements.
- The widest range of frame sizes (042-285) and ratios (3-100) available in the market.
- Best-in-class backlash (≤ 3 arc-min), with reduced backlash option available.
- Broad range of mounting adapters offer a simple, precise attachment to any motor.
- Maintenance-free solution that is lubricated for life. High performance grease allows for flexible mounting in any orientation.
- Industry standard mounting dimensions.
- Assembled in the USA, with immediate delivery.

VR Features

- 1 Carburized helical gears with proprietary secondary finishing process for higher accuracy and smooth, quiet operation. 40% higher tooth surface area than the industry standard.
- 2 One piece output shaft and planet carrier with two bearings straddling the planet gears. Higher stiffness, torque capacity and safety factor, with guaranteed alignment of gearing.
- 3 Uncaged needle roller bearings provide excellent torque density and torsional rigidity. 43% larger bearing surface area compared to the rest of the industry.
- 4 Unique labyrinth input seal design greatly reduces heat and increases system efficiency. IP65 protection is available for wash down applications.
- 5 Optimized mounting system with active centering on motor pilot diameter guarantees alignment of motor. Motor can be installed in any orientation.
- 6 True concentric motor shaft clamping connection, optimized for your specific motor. Reduced inertia for dynamic performance and balanced for high speed operation.
- 7 Ring gear machined directly into the housing, not welded or pressed in. Provides greater concentricity and elimination of speed fluctuation.



					
Product Series	VRSF	VRL	VRB	VRS	VRT
Axis of Orientation	Inline	Inline	Inline	Inline	Inline
Gear Technology	Helical Planetary	Helical Planetary	Helical Planetary	Helical Planetary	Helical Planetary
Frame Size Range	050-120	050-235	042-220	060-240	047-285
Ratio Range	3-81	3-100	3-100	3-100	4-100
Output Mounting Style					
Solid Keyed Shaft, tapped holes	■	■			
Solid Keyed Shaft, through holes			■	■	
Solid Smooth Shaft, tapped holes		■			
Solid Smooth Shaft, through holes			■	■	
Flange Output					■
Hollow Shaft					
Output Bearing Type					
Ball Bearing	■	■	■		■
Tapered Roller Bearing				■	■
Cross Roller Bearing					
Performance Specification					
Nominal Output Torque Range [Nm]	2.4-91.4	6-1500	6-1500	18-2400	6-3300
Max. Acceleration Torque Range [Nm]	7.3-274	12-2300	12-2300	24-3700	12-5300
Emergency Stop Torque Range [Nm]	17-393	30-5000	30-5000	80-8000	30-12000
Radial Load Range [N]	1670-3530	710-15000	710-15000	3000-30000	1100-86000
Axial Load Range [N]	833-1765	640-14000	640-14000	2700-27000	550-64000
Backlash [Arc-min]	≤15	≤5	≤3	≤3	≤3
Torsional Rigidity [kgcm ²]	Suitable	Suitable	Suitable	Suitable	Superior
Efficiency [%]	Superior	Superior	Superior	Superior	Superior
Service Life [Hours]	20,000	20,000	20,000	20,000	20,000
Lubrication					
Grease	■	■	■	■	■
Oil					

EV Series Right-angle Planetary Gearheads

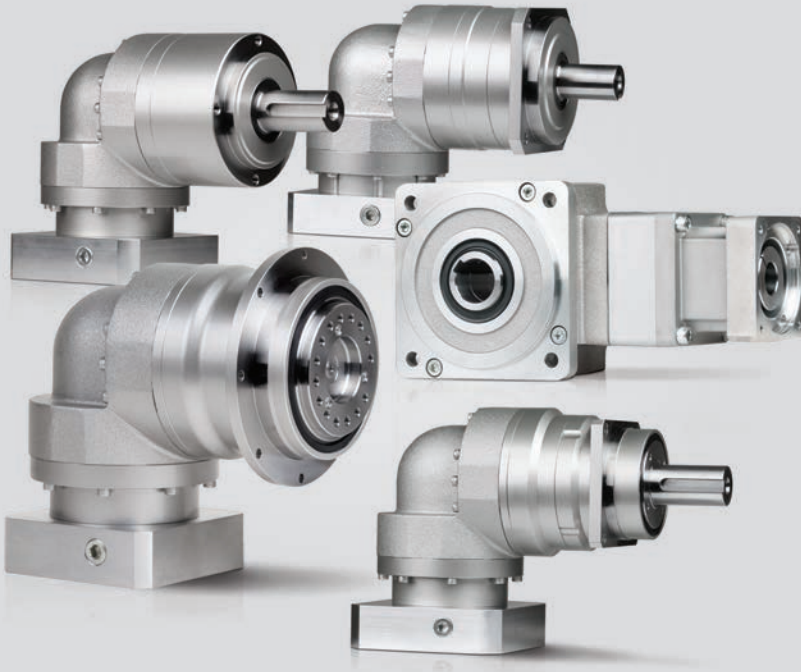



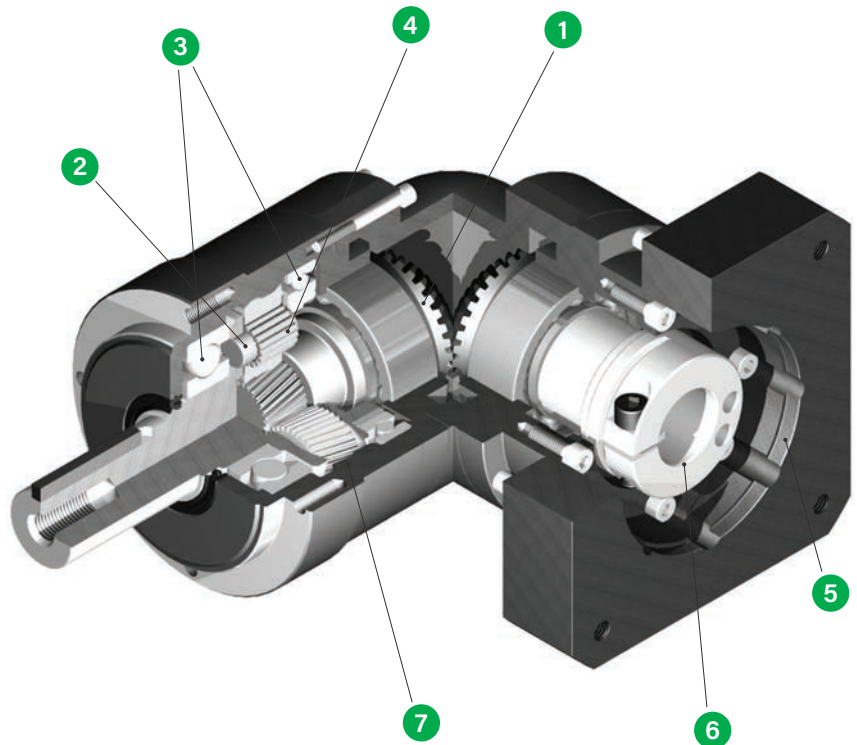

- Compact right-angle design for application where space and clearance are a serious limitation.
- Exceptional value for mid to high end motion control applications with demanding accuracy requirements.
- The widest range of frame sizes (060-255) and ratios (3-105) available in the market.
- Broad range of mounting adapters offer a simple, precise attachment to any motor.
- Maintenance-free solution that is lubricated for life. High performance grease allows for mounting in any orientation.
- Hollow output shaft available for flexible mounting to machinery.
- Assembled in the USA.

EV Features

- 1 Right angle bevel gear configuration allows motor to be mounted at a 90 degree position from the gearbox, saving space.
- 2 Carburized helical gears with proprietary secondary finishing process for higher accuracy and smooth, quiet operation. 40% higher tooth surface area than the industry standard.
- 3 One piece output shaft and planet carrier with two bearings straddling the planet gears. Higher stiffness, torque capacity and safety factor, with guaranteed alignment of gearing.
- 4 Uncaged needle roller bearings provide excellent torque density and torsional rigidity. 43% larger bearing surface area compared to the rest of the industry.
- 5 Optimized mounting system with active centering on motor pilot diameter guarantees alignment of motor. Motor can be installed in any orientation.
- 6 True concentric motor shaft clamping connection, optimized for your specific motor. Reduced inertia for dynamic performance and balanced for high speed operation.
- 7 Ring gear machined directly into the housing, not welded or pressed in. Provides greater concentricity and elimination of speed fluctuation.



					
Product Series	NEV	EVL	EVB	EVS	EVT
Axis of Orientation	Right-angle	Right-angle	Right-angle	Right-angle	Right-angle
Gear Technology	Spiral Bevel/Planetary	Spiral Bevel/Planetary	Spiral Bevel/Planetary	Spiral Bevel/Planetary	Spiral Bevel/Planetary
Frame Size Range	050-120	070-235	060-220	060-240	064-255
Ratio Range	5-105	3-100	3-100	3-100	4-100
Output Mounting Style					
Solid Keyed Shaft, tapped holes		■			
Solid Keyed Shaft, through holes	■		■	■	
Solid Smooth Shaft, tapped holes		■			
Solid Smooth Shaft, through holes			■	■	
Flange Output					■
Hollow Shaft	■				
Output Bearing Type					
Ball Bearing	■	■	■		
Tapered Roller Bearing				■	■
Cross Roller Bearing					
Performance Specification					
Nominal Output Torque Range [Nm]	6-90	12-1200	12-1200	12-1920	16-1920
Max. Acceleration Torque Range [Nm]	20-180	24-1840	24-1840	24-2960	32-2960
Emergency Stop Torque Range [Nm]	35-300	50-4500	50-4500	50-7200	65-7200
Radial Load Range [N]	1800-4000	1200-15000	1200-15000	3000-30000	1500-40000
Axial Load Range [N]	500-2000	1100-14000	1100-14000	2700-27000	750-20000
Backlash [Arc-min]	≤30	≤6-11	≤4-9	≤4-9	≤4-9
Torsional Rigidity [kgcm ²]	Suitable	Suitable	Suitable	Suitable	Superior
Efficiency [%]	Suitable	Superior	Superior	Superior	Superior
Service Life [Hours]	20,000	20,000	20,000	20,000	20,000
Lubrication					
Grease	■	■	■	■	■
Oil					

EJ Series Servo Worm Gearheads





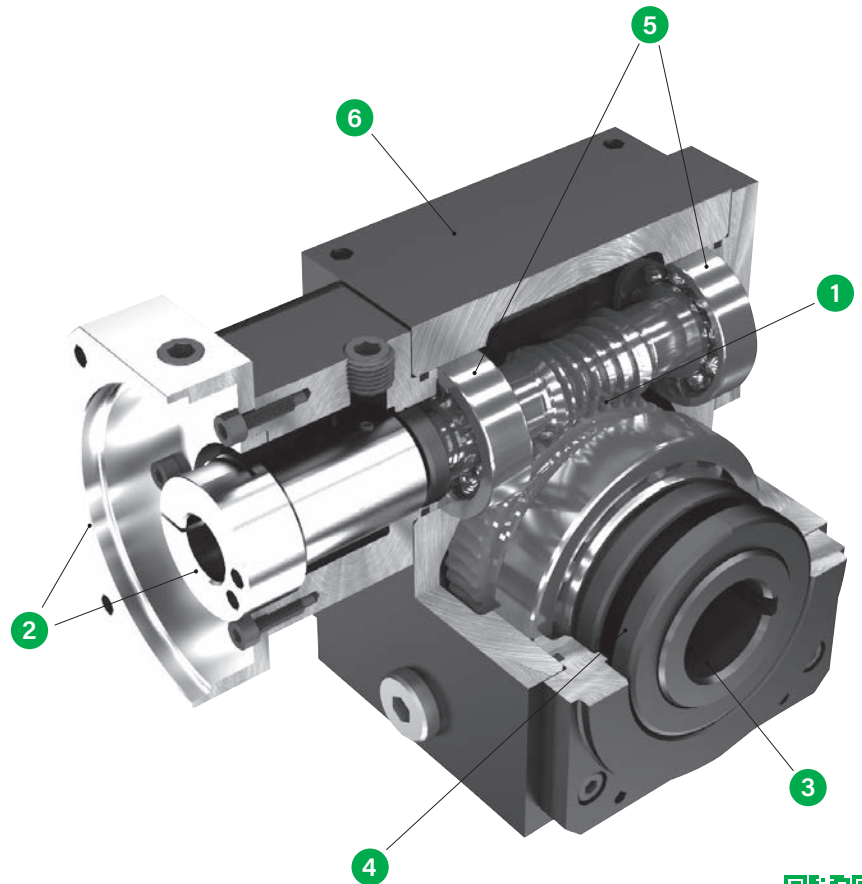

- Exceptionally quiet, smooth running design. Zero backlash available.
- No change in envelope with increase in ratio. Up to 90:1 available in a single stage.
- 300% shock load capacity combined with high overhung load capacity.
- High repeatability with exact ratios, beneficial for tuning.
- Excellent fit for continuous duty applications with continuous running speeds as high as 4,000 rpm.
- Flexible mounting options include solid shaft, hollow shaft, dual shaft, ISO flange and shrink disc.
- Superior environmental protection: stainless, black anodized or white epoxy coatings; IP65 or IP69K rated, with double input and output seals.

EJ Features

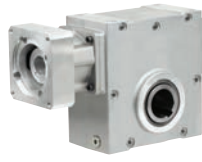
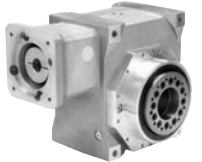
- 1 Globoidal gear set – between 3-8 teeth in contact at once, allowing 300% shock load capacity.
- 2 Adapter-bushing connection allows simple mounting to virtually any servomotor manufacturer.
- 3 Wide range of output mounting styles available – hollow shaft, solid shaft, dual shaft, shrink disc, ISO flange.
- 4 Double oil seal and o-ring provide IP65 protection.
- 5 Tapered roller or ball bearings at input side.
- 6 Thermally efficient housings available in anodized aluminum, cast iron or stainless steel.



					
Product Series	EJM	EJL	EJH	EJP	EJS
Axis of Orientation	Right-angle	Right-angle	Right-angle	Right-angle	Right-angle
Gear Technology	Globoidal Worm	Globoidal Worm	Globoidal Worm	Globoidal Worm	Globoidal Worm
Frame Size Range	02-09	25-200	15-35	38-89	39-76
Ratio Range	5-60	5-90	5-60	5-60	5-60
Output Mounting Style					
Solid Keyed Shaft, tapped holes	■	■	■	■	■
Solid Keyed Shaft, through holes					
Solid Smooth Shaft, tapped holes					
Solid Smooth Shaft, through holes					
Flange Output		■	■	■	
Hollow Shaft	■	■	■	■	■
Output Bearing Type					
Ball Bearing	■				
Tapered Roller Bearing		■	■	■	■
Cross Roller Bearing					
Performance Specification					
Nominal Output Torque Range [Nm]	29-505	8-3788	35-475	35-480	42-396
Max. Acceleration Torque Range [Nm]	33-614	13-6250	46-663	46-660	56-519
Emergency Stop Torque Range [Nm]	58-1010	35-12826	128-2889	105-1440	83.6-792
Radial Load Range [N]	1780-9780	1500-88000	3110-15560	3110-15560	2670-10235
Axial Load Range [N]	1330-5780	500-71000	1780-4000	1780-4000	2670-10235
Backlash [Arc-min]	≤12-40	≤0.5-15	≤6-32	≤0-24	≤8-24
Torsional Rigidity [kgcm ²]	Suitable	Suitable	Suitable	Suitable	Suitable
Efficiency [%]	Suitable	Suitable	Suitable	Suitable	Suitable
Service Life [Hours]	25,000	25,000	25,000	25,000	20,000
Lubrication					
Grease					
Oil	■	■	■	■	■

STH Series Rotary Index Tables

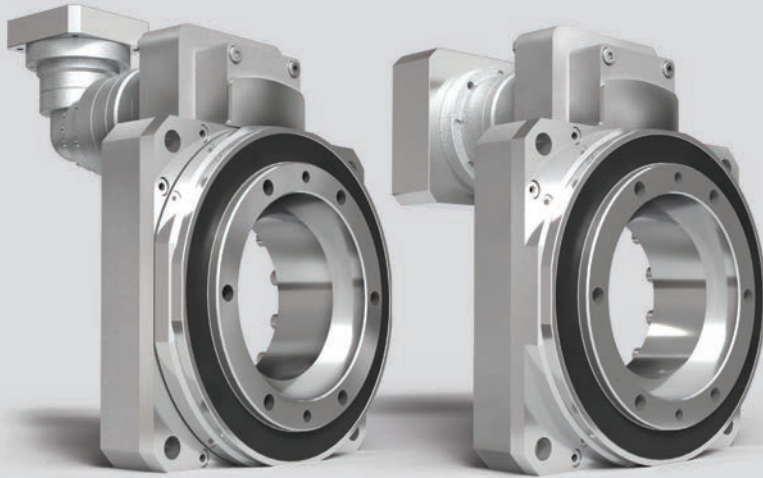

- 85mm pass through hole allows pass through of air lines, wiring or other peripheral components.
- ≤ 2 arc-min backlash with ± 60 arc-sec indexing accuracy.
- Reduction ratios from 12:1 up to 400:1.
- 5000N radial load capacity, ideal for mid-range index table applications.
- Broad range of mounting adapters offer a simple, precise attachment to any motor.
- Maintenance-free solution that is lubricated for life. High performance grease allows flexible mounting in any orientation.
- Assembled in the USA with immediate delivery.

STH Features

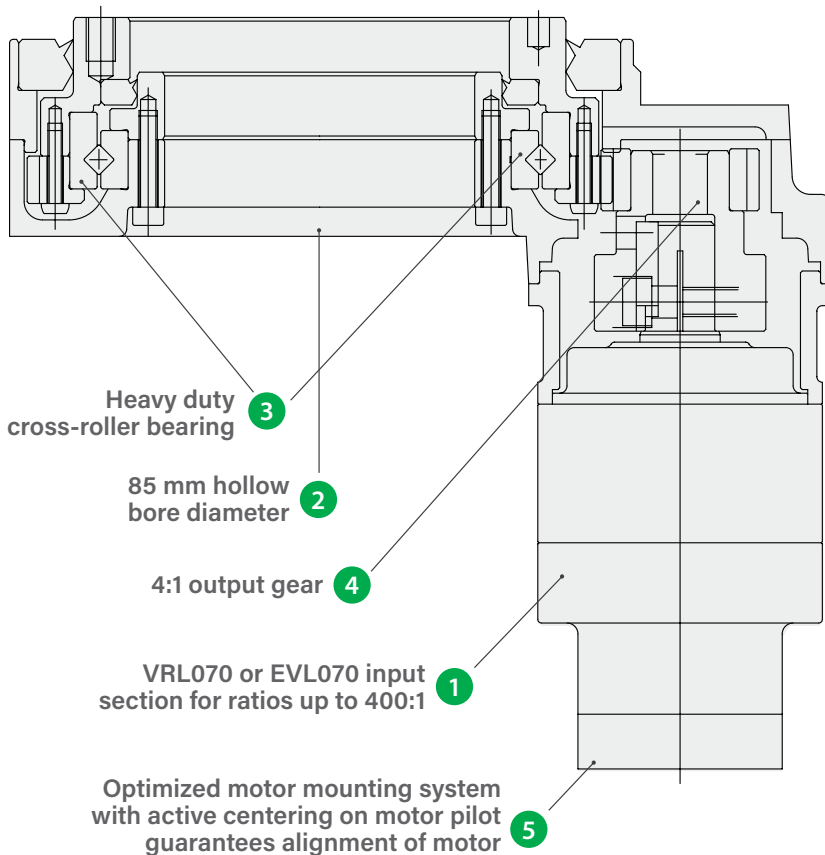

Drive Directions

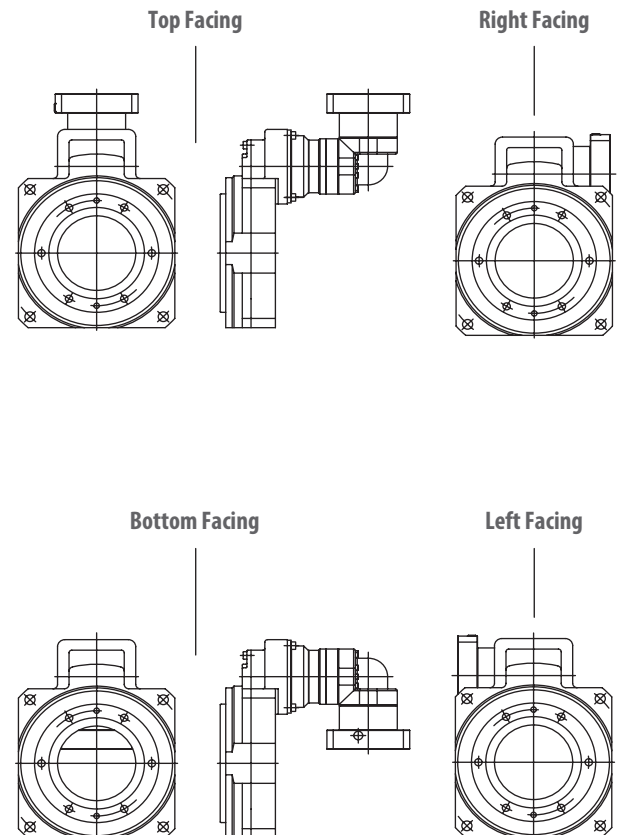

STR Series Rotary Index Tables



- Highest level of positioning accuracy and runout accuracy, difficult to attain with other gearing technologies.
- Zero Backlash Available – a unique preload mechanism to completely eliminate backlash and deliver motion that is true to input commands.
- Impressive dynamics – Exceptional with direction reversing applications.
- Reduction ratios up to 2000:1 are possible using a planetary primary stage.
- Lightweight, compact aluminum alloy housing for minimal footprint.
- Excellent fit for rotary pick and place applications, large dial tables, positioners and transfer systems.
- Maintenance free solution using grease lubrication, can be mounted in any position.

STR Features



Preload

Wedge-shape ribs on input shaft maintain contact with the roller followers under preload to completely remove backlash.



Hollow Output Shaft

The output shaft has an oversized hollow bore that allows easy passage of wiring and air lines, or the shaft of another device, for extended design flexibility.



Input Shaft

The steel alloy input shaft is made to meet extremely tight tolerances. These shafts are balanced to suppress vibration under high speed rotation.



Cross Rollers

Cross roller bearings are used inside the output unit for increased rigidity and minimal runout.



Roller Followers

Roller bearing construction transfers torque by the rolling action of the roller followers. Rolling contact maintains initial accuracy for extended periods of use.

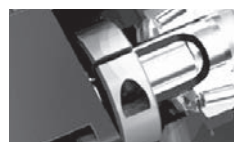

Input Clamping System

The motor or gearbox shaft is rigidly clamped to the input shaft of the rotary unit for a direct transfer of power.

Key Specifications	
Axis of Orientation	Inline, Right-angle
Gear Technology	Globoidal Cam
Frame Size Range	040-250
Ratio Range	15-2000
Output Bearing Type	Cross Roller
Max Input Speed [Rpm]	6000
Max Radial Load Range [N]	669-11165
Max Axial Load Range [N]	999-38051
Max Tilting Moment Load Range [Nm]	33-2478.6
Backlash [Arc-min]	0
Transmission Accuracy Range [Arc-min]	≤0.7-≤1.5
Repeatability Accuracy Range [Arc-min]	0.12
Torsional Rigidity [kgcm ²]	Superior
Efficiency [%]	Suitable
Lubrication	Grease



WP Strain Wave Gears



- Strain wave gear reduction mechanism that achieves zero backlash, as well as exceptional positioning accuracy, repeatability and high torque density.
- High reduction ratios in a single stage. Lightweight and compact design.
- Various form factors, including component sets, simple contained assemblies and complete gear units. Cup, Silk Hat, Solid and Hollow Shaft configurations give engineers true design freedom.
- Available in Ultra-Flat and High Torque variations for applications with demanding footprint and performance requirements.
- Industry standard dimensions for simple implementation in legacy equipment designs.
- Superior choice for Robotics, Machine Tool, Medical, Semiconductor, SatCom and Assembly Automation applications.

Size	Ratio	Nominal Output Torque [Nm]	Maximum Output Torque [Nm]	Emergency Stop Torque [Nm]
28	50	3.5	8.3	17
	100	5	11	25
35	50	7	23	46
	80	9	27	55
	100	9	32	63
42	50	21	44	91
	80	26	50	102
	100	28	63	129
	120	28	63	129
50	50	33	73	127
	80	40	86	149
	100	47	96	172
	120	47	96	172
	160	47	96	172
63	50	51	127	242
	80	66	142	266
	100	70	163	295
	120	70	163	295
	160	70	163	295
80	50	89	253	447
	80	122	316	590
	100	142	346	673
	120	142	346	673
	160	142	346	673

FLEXWAVE

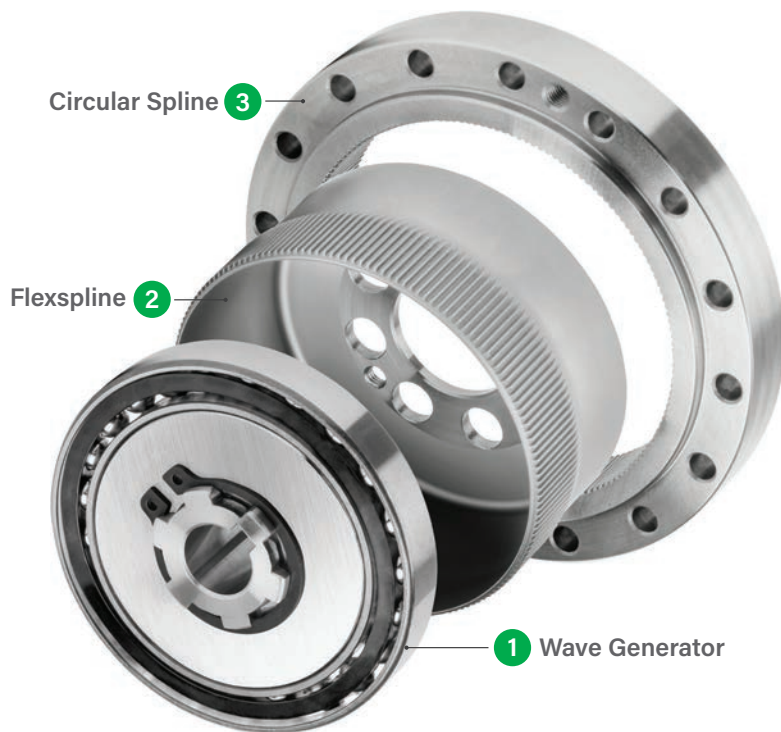

FLEXWAVE



- Compact, lightweight gear reducer with integrated multi-sensor system.
- Built-in torque sensor for precise output torque control.
- Temperature monitoring for improved stability and reliability.
- High-accuracy angle sensor with torque compensation.
- Dual-channel design for collaborate robot safety.
- Multi-drop connection supports up to 8 axes with simplified wiring.

Size	Ratio	Nominal Output Torque [Nm]	Maximum Output Torque [Nm]	Emergency Stop Torque [Nm]
35	50	7	23	46
	80	10	30	61
	100	10	36	70
42	50	21	44	91
	80	29	56	113
	100	31	70	143
	120	31	70	112
50	50	33	73	127
	80	44	96	165
	100	52	107	191
	120	52	113	191
	160	52	120	191
63	50	51	127	242
	80	82	178	332
	100	87	204	369
	120	87	217	395
	160	87	229	408
80	50	99	281	497
	80	153	395	738
	100	178	433	841
	120	178	459	892
	160	178	484	892

Smart-FLEXWAVE

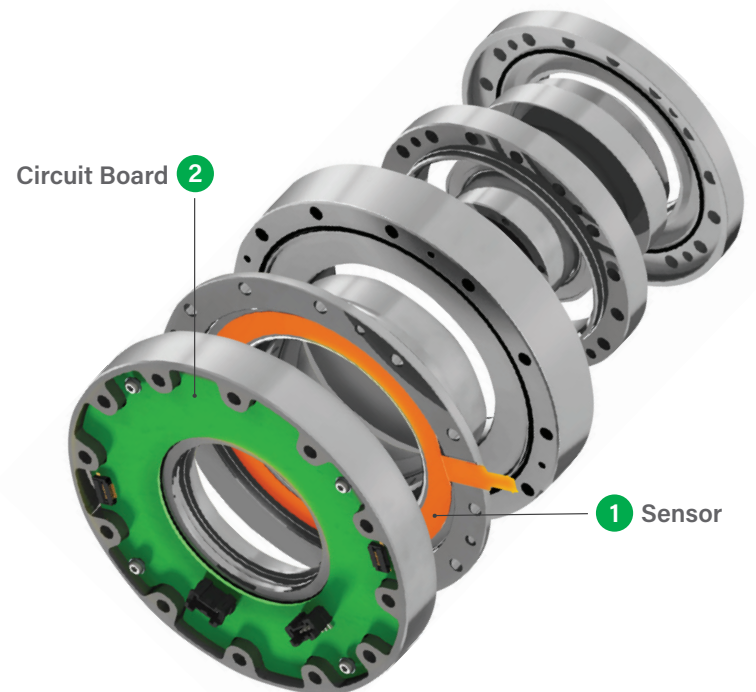

EH Cycloidal Reducers

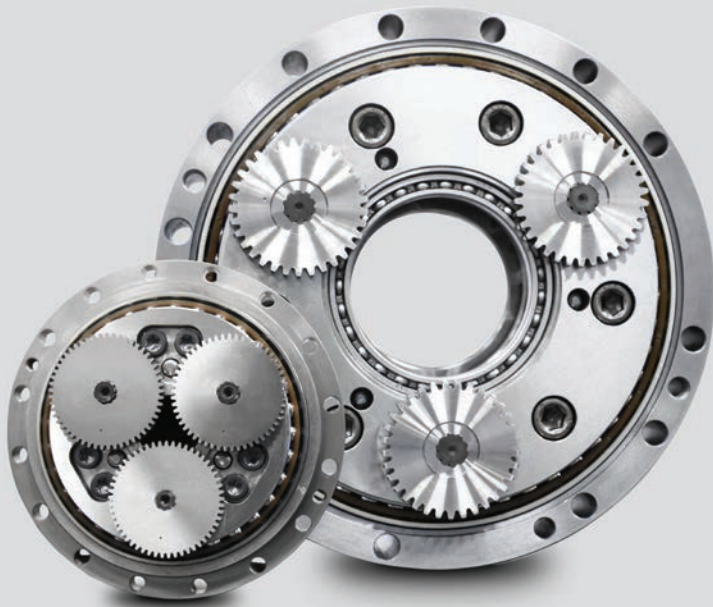

- Smooth and quiet high precision cycloidal reducers.
- Provides exceptional movement for various applications, such as robots and machine tools.
- EH Series Type N is a solid shaft type cycloidal reducer that is lightweight and compact.
- EH Series Type C is a hollow shaft type large size reducer that provides a pass through for cable or hose application solutions.
- Flexible integration into robotic joints, positioners, turntables or other automated machinery.

KINEX

Mechanism Diagram

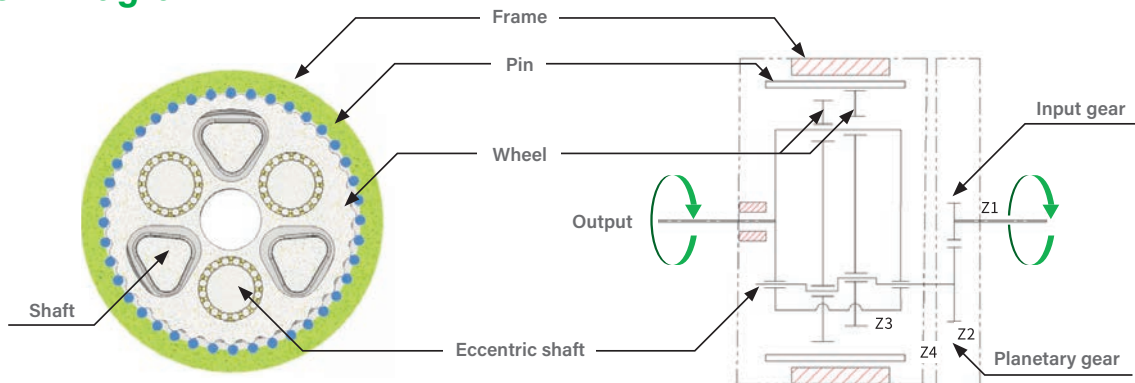

Component Structure

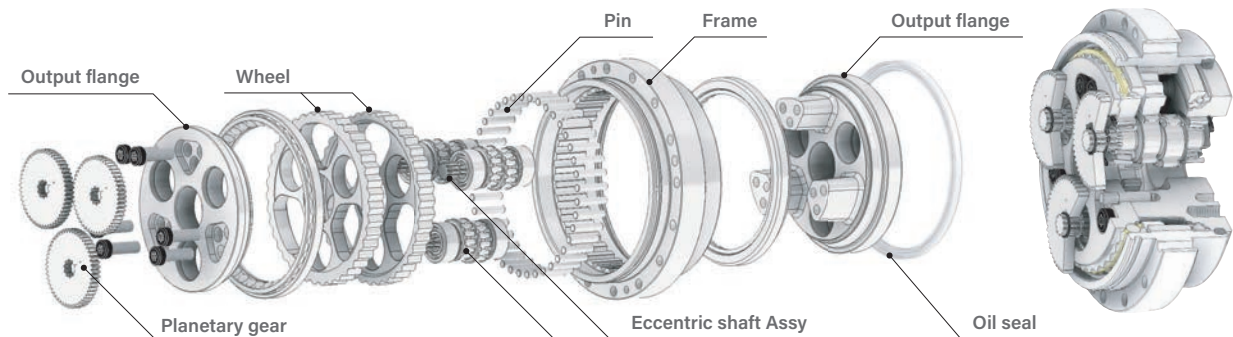

KINEX

Selection Tool Configurator

NIDEC DRIVE TECHNOLOGY's Online Product Configurator makes it easier than ever for engineers to incorporate our products into their drive system design. Our configurator allows our customers to select from wide range of servo motor manufacturer models to ensure flawless fitment with our products. With over 75 motor manufacturers included, there is a good possibility we have a solution ready to go.

In addition to motor sizing, our configurator also allows our customers to select gearheads based on application. These applications include rotary tables, belt conveyors, rack and pinion drives, lifting and lowering devices, ball screws, drive gears, drive carriages and robot joints. After selecting the application template, customers can then input the application load parameters and motion profile. The proper frame size and reduction ratio are then determined, with motor selection as the final last step.

Once sizing is complete, our configurator will then display the full part number, along with gearbox and motor technical specifications. This part number includes the motor mounting adapter, which can be sent directly to our sales support team for pricing & delivery.

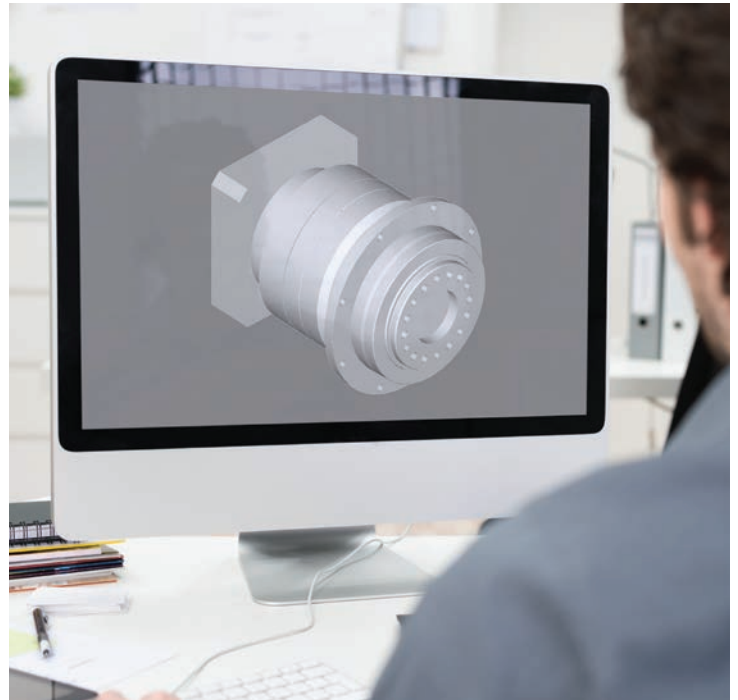

Drawings and models are also available in PDF, DXF, IGS and STEP formats, making it simple for machine designers to quickly drop them into machine schematics to check for proper fitment. We have seasoned application engineers standing by to assist with any sizing or selection questions.

<https://www.nidec-drivetechnology.co.jp/selection/all/>

Application Selection



Rotary Table

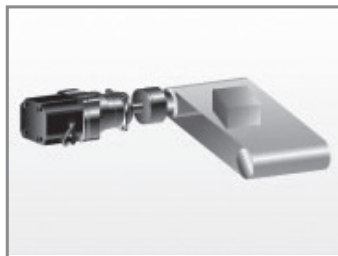

Belt Conveyor

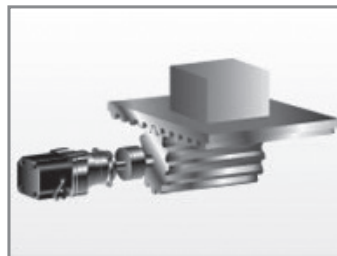

Rack and Pinion



Lifting & Lowering Device

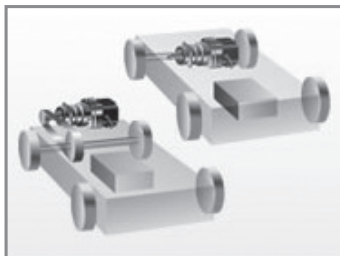

Drive Carriage

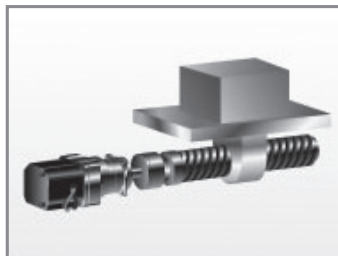

Ball Screw



Drive Gears

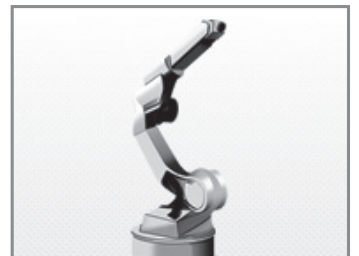

Robot Joints



nidec-dtc.com

Nidec

NIDEC DRIVE TECHNOLOGY CORPORATION
175 Wall Street, Glendale Heights, IL 60139 USA
Phone: (800) 842-1479 • info@nidec-dtc.com