



Compact & Configurable Bevel Gearboxes



TwinGear and PowerGear Series

Reliable and Highly Efficient

NIDEC DRIVE TECHNOLOGY CORPORATION

Legacy of innovation in Bevel Gearing

Nidec Drive Technology Corporation acquired MS-Graessner GmbH & Co. KG, based out of Dettenhausen, Germany, in 2018. This strategic acquisition gives us over 60 years of design and manufacturing experience in the area of high precision helical bevel, spiral bevel and hypoid gears. It strengthens our position in the European market by giving our global customer base unparalleled access to a broad range of gear technologies with local product distribution and expertise.

By way of the Gleason manufacturing process, our Dettenhausen facility and highly skilled 120-person workforce excels in producing solutions for custom and highly specialized applications. Whether it's for a specific single piece project or for mass production, we develop the best possible engineering solution—providing more power density, less noise, higher efficiency and more precision at every turn.

Our bevel gear product families—TwinGear and PowerGear—were developed as a result of in-depth knowledge of different industry sectors and applications. We offer a wide range of frame sizes, ratios and mounting configurations to meet virtually any requirement. The success of our customers is the top priority for Nidec DTC. Our product quality, reliability and availability give our customers a competitive advantage as they continue to improve their machine performance to compete globally.



Index

TwinGear

Overview.....	2
Featured Highlights	4
Model Code	5
Performance Specifications.....	6
Dimensions and Configurations.....	8
Mounting Options.....	10
Installation Information.....	12
Gearbox Selection & Maintenance.....	13

PowerGear

Overview.....	14
Featured Highlights	16
Model Code	17
Performance Specifications.....	18
Dimensions and Configurations.....	22
Options & Modifications	38
Installation Information.....	39
Gearbox Selection & Maintenance.....	40

TWINGEAR SERIES

TwinGear harnesses the power of two with its hypoid primary stage and helical secondary stage. This gear train redefines power, compactness and precision, setting benchmarks in the industry. High torsional stiffness and backlash <6 arc-minutes and make it a contender in dynamic motion control applications. With ratios spanning from 15-75:1 and maximum acceleration torque as high as 11,250Nm, TwinGear can be applied confidently across a myriad of applications.

Our customers demanded a more compact helical bevel design and we answered. TwinGear can fit in the narrowest space envelopes. Solid shaft, dual shaft, hollow shaft and shrink disc mounting interfaces provide the ultimate flexibility for machine designers. Rated up to 8,000rpm, this product outperforms in high speed, continuous duty applications while staying quiet and cool.

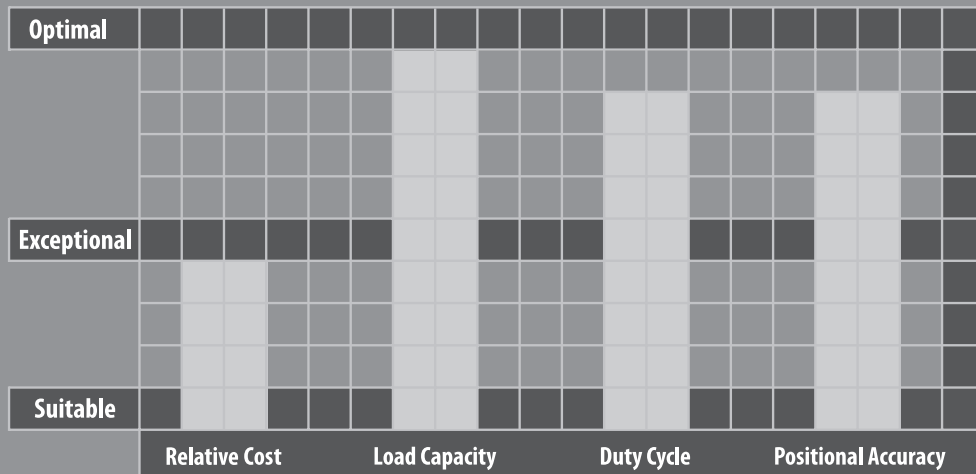



TWINGEAR SERIES

- High performing helical-bevel two-stage gearbox with maximum acceleration torque as high as 11,250Nm
- Low backlash (<4 arc-min) with exceptional torsional rigidity
- 8 Frame sizes and 8 ratios available, up to 75:1
- Suitable for high input speeds up to 8,000 rpm
- Extremely compact design to fit into challenging space envelopes
- Assembled in Germany

Featured Highlights

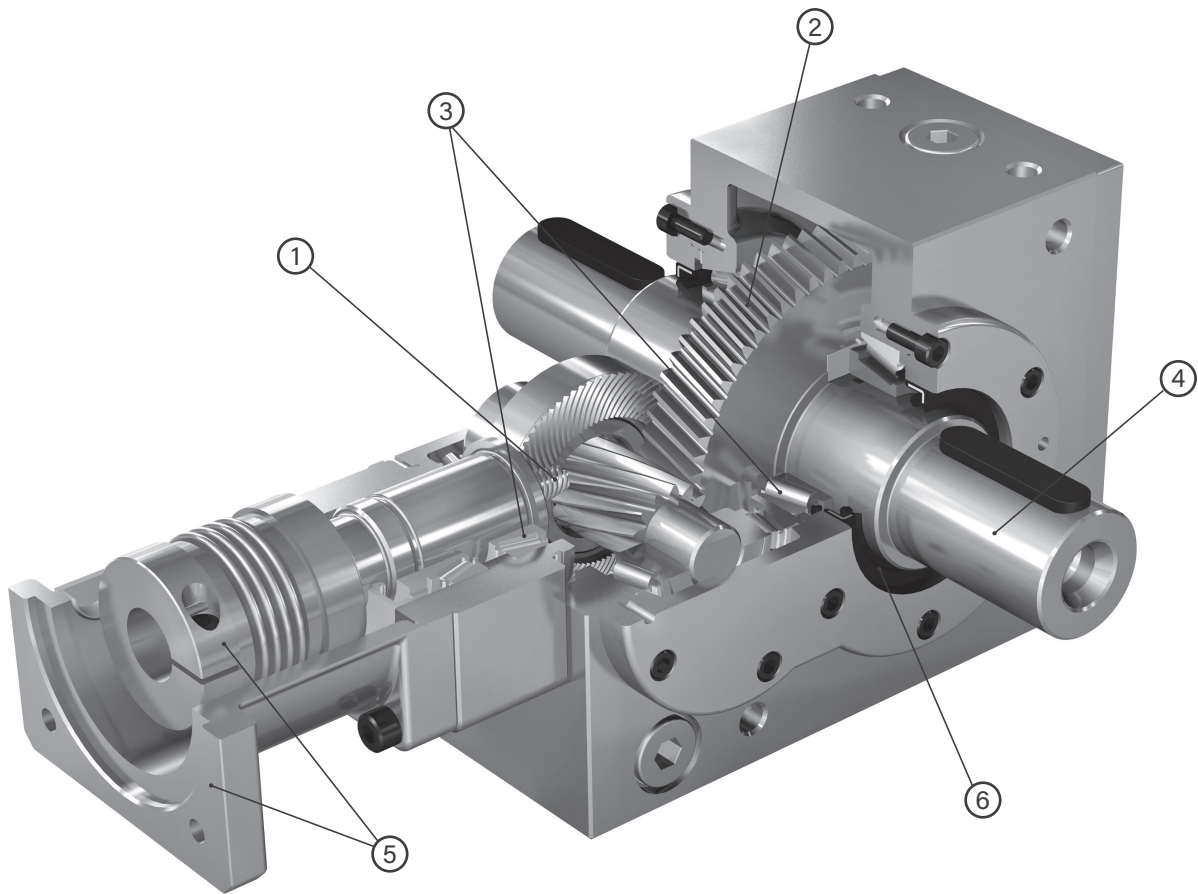

- ① Hypoid primary stage with optimized contact pattern for uniform load distribution, low noise and high transmission accuracy
- ② Helical secondary stage for high torque generation
- ③ Tapered roller bearings at input and output for high radial and axial load capacity
- ④ Four output mounting styles for maximum flexibility: Keyed solid shaft, keyed dual shaft, keyed hollow shaft and hollow shrink disc
- ⑤ Simple, low inertia connection to various servo motors using adapter flange and stiff zero backlash coupling
- ⑥ Output seal allows for IP64 protection

Model Code

KS	20	KH	25	13L	XXX
Series Name	Frame Size	Output mounting type	Ratio	Shaft Arrangement	*Motor mounting code
KS TwinGear	10 20 30 35 40 50 60 70	KL: Solid Out Shaft KH: Hollow Output Shaft	15 20 25 30 40 50 60 75	1L: Keyed Solid Shaft Left 3L: Keyed Solid Shaft Right 13L: Keyed Dual Solid Shaft 13L: Keyed Hollow Shaft 1LSV: Hollow Shrink Disc Shaft Right 3LSV: Hollow Shrink Disc Shaft Left	Motor mounting code varies depending on the motor

* Motor mounting code varies depending on the motor. Contact us to configure the code.

Performance Specifications

Frame Size	Unit	Note	10	20	30	35	40	50	60	70
Ratio	i		15 / 20 / 25 / 30							
Nominal Output Torque	T2N [Nm]	*1	150	250	480	950	1750	3200	5000	7500
Maximum Acceleration Torque	T2B [Nm]	*2	225	375	720	1425	2625	4800	7500	11250
Emergency Stop Torque	T2Not [Nm]	*3	300	500	960	1900	3500	6400	10000	15000
Nominal Input Speed	n1N [rpm]	*4	2400	2400	2000	1600	1300	900	800	700
Maximum Input Speed	n1max [rpm]	*5	8000	7000	6000	5000	4000	4000	3500	3500
Maximum Radial Load	F2Rmax [N]	*6	4900	7200	10000	15000	18000	25000	30000	35000
Maximum Axial Load	F2Amax [N]	*7	2450	3600	5000	7500	9000	12500	15000	17500
Efficiency	h [%]	*8	> 92	> 92	> 92	> 92	> 92	> 92	> 92	> 92
Torsional Rigidity	Ct21 [Nm/arcmin]	*9	10	16	34	75	150	377	473	726
Maximum Torsional Backlash	jt [arcmin]	*10	≤ 6	≤ 6	≤ 6	≤ 5	≤ 5	≤ 4	≤ 4	≤ 4
Noise Level	LpA [dB(A)]	*11	< 69	< 69	< 71	< 71	< 73	< 73	< 75	< 75
Ambient Temperature	[°C]	-	-10 to 90							
Permitted Housing Temperature	[°C]	-	90							
Protection Class	-	-	IP64							
Lubrication	-	-	Synthetic Oil [ISO VG-Class 150]							
Service Life	SL [h]	*12	30,000							
Weight	m [kg]	-	10	16	27	52	75	115	190	300

Frame Size	Unit	Note	10	20	30	35	40	50	60	70
Ratio	i		40 / 50							
Nominal Output Torque	T2N [Nm]	*1	110	200	360	700	1300	3200	5000	7500
Maximum Acceleration Torque	T2B [Nm]	*2	165	300	540	1050	1950	4800	7500	11250
Emergency Stop Torque	T2Not [Nm]	*3	220	400	720	1400	2600	6400	10000	15000
Nominal Input Speed	n1N [rpm]	*4	3700	3700	3100	2500	2100	1400	1300	1200
Maximum Input Speed	n1max [rpm]	*5	8000	7000	6000	5000	4000	4000	3500	3500
Maximum Radial Load	F2Rmax [N]	*6	4900	7200	10000	15000	18000	25000	30000	35000
Maximum Axial Load	F2Amax [N]	*7	2450	3600	5000	7500	9000	12500	15000	17500
Efficiency	h [%]	*8	> 92	> 92	> 92	> 92	> 92	> 92	> 92	> 92
Torsional Rigidity	Ct21 [Nm/arcmin]	*9	10	16	34	75	150	377	473	726
Maximum Torsional Backlash	jt [arcmin]	*10	≤ 6	≤ 6	≤ 6	≤ 5	≤ 5	≤ 4	≤ 4	≤ 4
Noise Level	LpA [dB(A)]	*11	< 69	< 69	< 71	< 71	< 73	< 73	< 75	< 75
Ambient Temperature	[°C]	-	-10 to 90							
Permitted Housing Temperature	[°C]	-	90							
Protection Class	-	-	IP64							
Lubrication	-	-	Synthetic Oil [ISO VG-Class 150]							
Service Life	SL [h]	*12	30,000							
Weight	m [kg]	-	10	16	27	52	75	115	190	300

Frame Size	Unit	Note	10	20	30	35	40	50	60	70
Ratio	i		60 / 75							
Nominal Output Torque	T2N [Nm]	*1	75	125	250	475	900	2550	4050	5100
Maximum Acceleration Torque	T2B [Nm]	*2	110	185	375	710	1350	3825	6075	7650
Emergency Stop Torque	T2Not [Nm]	*3	150	250	500	950	1800	5100	8100	10200
Nominal Input Speed	n1N [rpm]	*4	4500	4500	3900	3300	2700	1900	1600	1500
Maximum Input Speed	n1max [rpm]	*5	8000	7000	6000	5000	4000	4000	3500	3500
Maximum Radial Load	F2Rmax [N]	*6	4900	7200	10000	15000	18000	25000	30000	35000
Maximum Axial Load	F2Amax [N]	*7	2450	3600	5000	7500	9000	12500	15000	17500
Efficiency	h [%]	*8	> 90	> 90	> 90	> 90	> 90	> 90	> 90	> 90
Torsional Rigidity	Ct21 [Nm/arcmin]	*9	10	16	34	75	150	377	473	726
Maximum Torsional Backlash	jt [arcmin]	*10	≤ 6	≤ 6	≤ 6	≤ 5	≤ 5	≤ 4	≤ 4	≤ 4
Noise Level	LpA [dB(A)]	*11	< 67	< 67	< 69	< 69	< 71	< 71	< 73	< 73
Ambient Temperature	[°C]	-	-10 to 90							
Permitted Housing Temperature	[°C]	-	90							
Protection Class	-	-	IP64							
Lubrication	-	-	Synthetic Oil [ISO VG-Class 150]							
Service Life	SL [h]	*12	30,000							
Weight	m [kg]	-	10	16	27	52	75	115	190	300

*1 At nominal input speed, service life is 30,000 hours.

*2 The maximum torque when starting or stopping operation. Permitted 1,000 cycles/hour.

*3 The maximum torque allowed under a stress situation. Permitted 1,000 times during service life.

*4 Average input speed at nominal torque. Maintain housing temperature below 90°C.

*5 The maximum intermittent input speed.

*6 Maximum radial load gearbox can accept. Measured at center of output shaft at 400rpm.

*7 Maximum axial load gearbox can accept. Measured at center of output shaft at 400rpm.

*8 The efficiency at full load.

*9 At nominal output torque. Does not include lost motion.

*10 Measured at output, 2% load and max 10Nm.

*11 Measured at 1,500 rpm input at partial load.

*12 Based on S5 duty cycle <60% and <20 minute run time.

Performance Specifications

Moment of inertia I_1 [kgcm²]

Ratio	Frame Size							
	10	20	30	35	40	50	60	70
15:1	0.676	2.64	5.56	9.86	26.2	57.3	100.8	185
20:1	0.605	2.41	5.23	8.98	22.1	50.2	90.1	151
25:1	0.579	2.34	5.05	8.53	20.9	45.4	73.0	133
30:1	0.577	2.34	5.10	8.45	21.5	44.0	70.2	132
40:1	0.557	2.29	4.88	8.12	20.5	41.2	64.3	118
50:1	0.547	2.26	4.83	7.96	20.0	39.8	60.8	111
60:1	0.542	2.27	4.79	7.87	19.1	38.9	58.7	107
75:1	0.537	2.24	4.77	7.79	18.9	38.3	57.1	104

Units and Symbols

Maximum Motor Acceleration Torque	T1BMot	Nm
Nominal Output Torque	T2N	Nm
Maximum Acceleration Torque	T2B	Nm
Emergency Stop Torque	T2Not	Nm
Nominal Input Speed	n1N	rpm
Maximum Input Speed	n1max	rpm
Maximum Input Radial Load	F1Rmax	N
Maximum Output Radial Load	F2Rmax	N
Maximum Input Axial Load	F1Amax	N
Maximum Output Axial Load	F2Amax	N
Mass Moment of Inertia	I1	kgcm ²
Efficiency at Full Load		%
Torsional Rigidity	Ct21	Nm/arc-min
Maximum Torsional Backlash	jt	arc-min
Noise Level	LpA	dB(A)
Service Life	Lh	h
Run time	RT	min
Duty cycle	DC	%
Ambient Temperature	ta	°C
Thermal Performance Limit	Ptherm	kW
Performance	P	kW
Weight	m	kg

Dimensions and Configurations

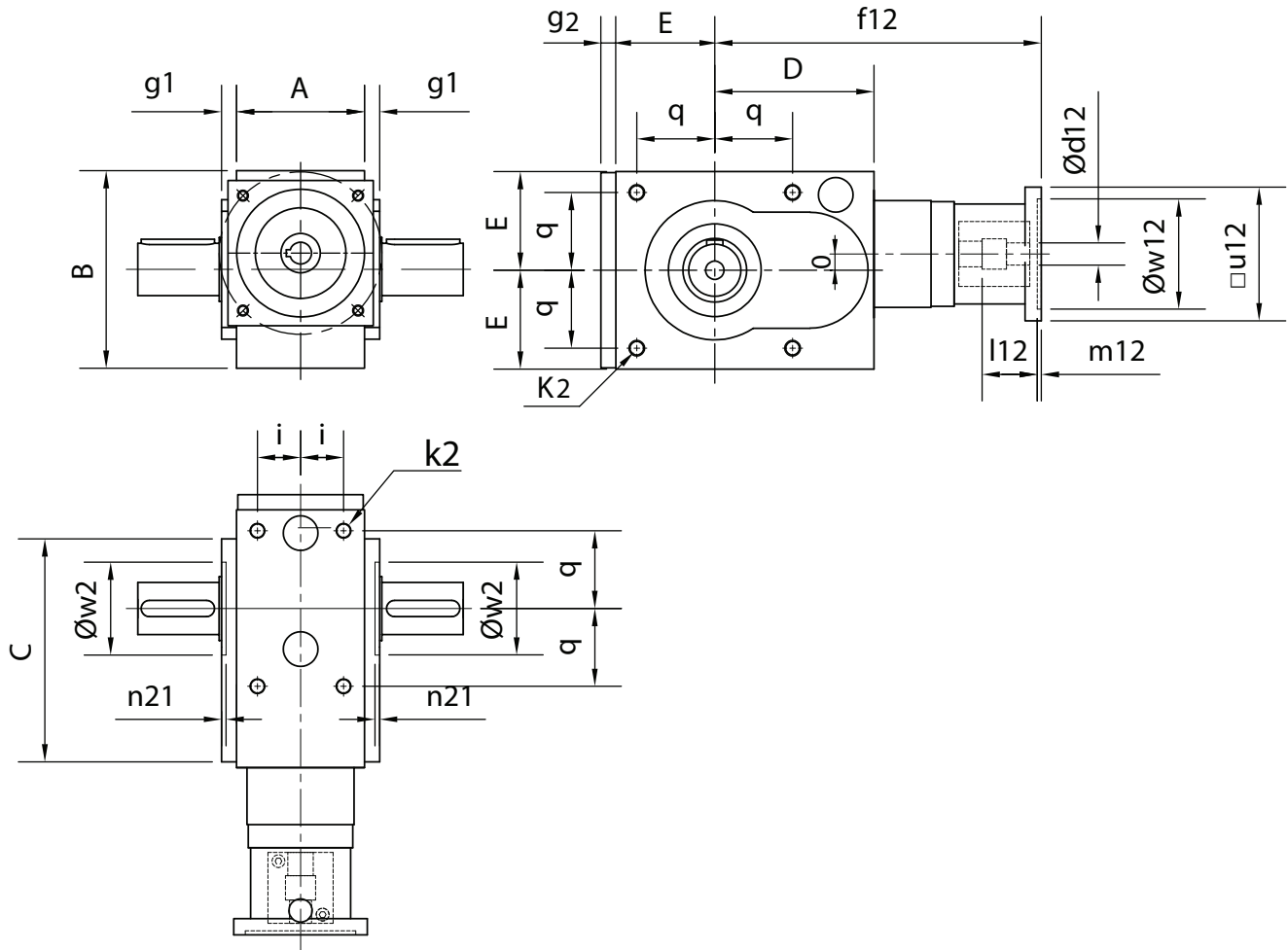

Base Dimensions

Frame Size	A	B	C	D	E	g1	g2	o	k2	q	i	w2H7	n21
10	75	110	147.5	92.5	55	10.5	10.5	7.5	M8	44	28	55	4
20	90	140	180	110	70	13	13	9	M10	55	30	63	4
30	110	170	222	137	85	13	13	14	M12	67	37	80	4
35	140	210	275	170	105	16	16	18	M16	85	50	95	6
40	170	240	322	202	120	16	16	23	M16	95	60	110	6
50	210	280	383	243	140	16	23	32	M16	110	75	120	6
60	240	360	475	295	180	18	25	38	M20	140	80	130	8
70	280	450	585	360	225	18	25	42	M20	175	90	160	10

Motor Adapter Flange and Coupling Dimensions

Frame Size	u12 x f12 (Motor Adapter)			Ød12 x l12 (Coupling)		
10	55x184	75x194	90x197	9x23	11x26	14x33
20	75x232	90x232	90x244	11x26	14x33	19x43
30	90x281	115x281	115x291	14x33	19x43	24x53
35	115x337	140x352	140x362	19x43	24x53	32x63
40	140x395	190x400	190x415	24x53	32x63	38x83
50	190x481	190x490	260x490	32x63	38x83	48x115
60	190x558	260x568	-	32x63	38x83	48x115
70	Contact us			Contact us		

*Above Motor Adapter Flange and Coupling Dimensions are for reference only and depend on motor dimensions. Contact us to configure adaptation for your specific motor.

Dimensions and Configurations

Keyed Solid Output Shaft

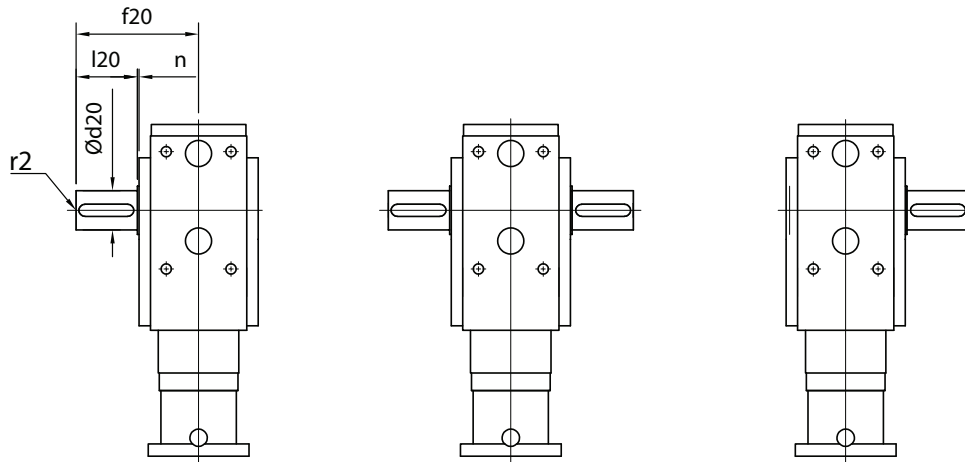

Shaft Arrangement 1L

Shaft Arrangement 13L

Shaft Arrangement 3L

Frame Size	Ø d20 k6	l20	f20	n	r2	Key
10	30	50	100	2	M10	8x7x45
20	35	55	115	2	M12	10x8x45
30	45	70	140	2	M16	14x9x63
35	55	85	174	3	M20	16x10x80
40	65	110	214	3	M20	18x11x100
50	80	130	254	3	M20	22x14x100
60	90	160	301	3	M24	25x14x140
70	100	180	341	3	M24	28x16x160

Hollow Shaft: Keyed and Shrink Disc

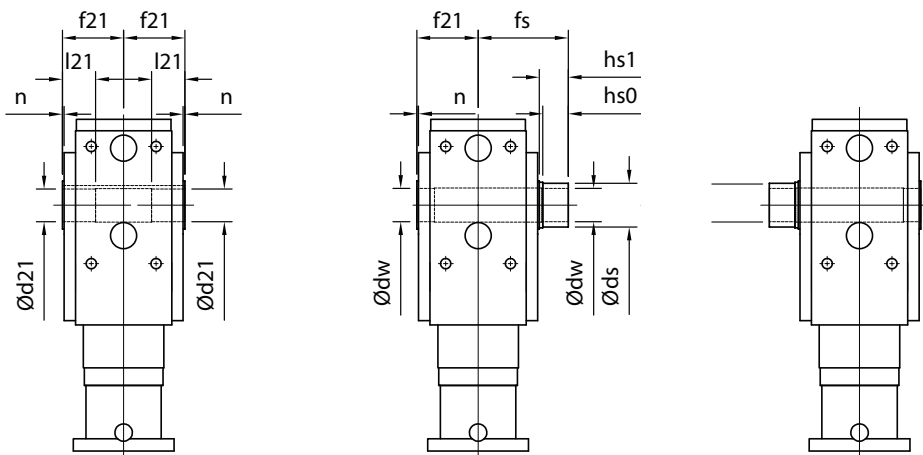

Shaft Arrangement 13L

Shaft Arrangement 1LSV

Shaft Arrangement 3LSV

Frame Size	Ød21 H7	l21	f21	n	Keyway	Ødw H7	Øds F7	hs0	hs1	fs
10	25	40	50	2	8x7	25	30	22	25	77
20	28	28	60	2	8x7	30	36	25.5	28.5	90
30	38	38	70	2	10x8	40	50	29	33	104
35	45	45	89	3	14x9	50	62	31.5	37	126
40	55	55	104	3	16x10	60	68	31.5	35	141
50	65	65	124	3	18x11	70	80	34	41	165
60	75	75	141	3	20x12	75	95	46.5	51	195
70	90	90	161	3	25x14	90	110	52	60.5	225

* Hollow output shaft arrangements 1LSV/3LSV include extended shrink disc shaft only. Shrink disc sold separately.

Mounting Options

Shrink Discs - For use with 1LSV/3LSV Hollow Shaft Configurations

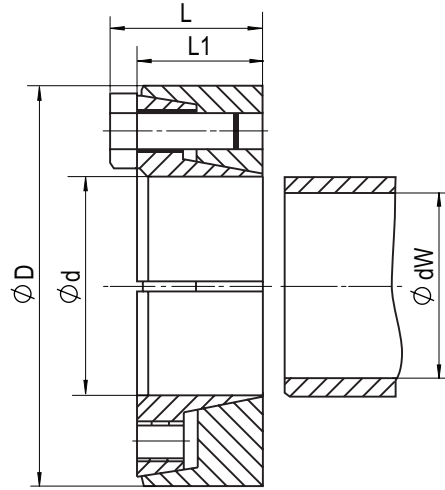

Frame Size	Shrink Disc Model	Ød	Ødw	ØD	L	L1	Torque (Nm)	Screw Size	Mass (kg)
10	KBS 19/1 - 30x60	30	25	60	24	20	352	M6	0.3
20	KBS 19/1 - 36x72	36	30	72	27.3	22	714	M8	0.5
30	KBS 19/1 - 50x90	50	40	90	31.3	26	1490	M8	0.8
35	KBS 19/1 - 62x110	62	50	110	34.3	29	2230	M8	1.4
40	KBS 19/1 - 68x115	68	60	115	34.3	29	3590	M8	1.4
50	KBS 19/1 - 80x145	80	70	145	37.4	31	5400	M10	2.5
60	Contact Us	-	-	-	-	-	-	-	-
70	Contact Us	-	-	-	-	-	-	-	-

Keyed Input Shaft Option

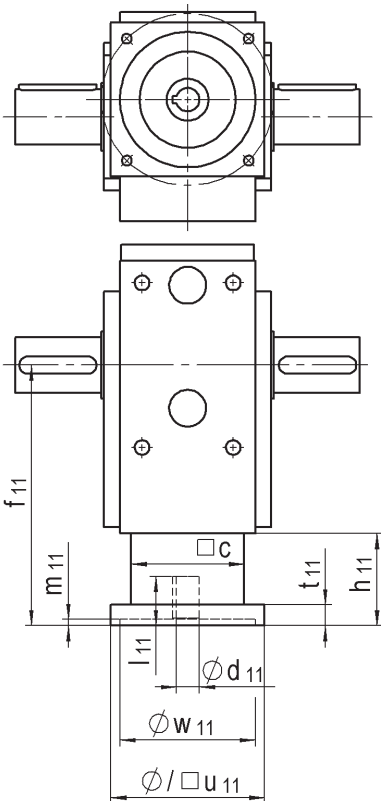

Motor Adapter Flange and Input Keyway Dimensions

Frame Size	Ød11 x l11			f11	h11	t11	c	m1
10	9x23	11x26	14x33	155	62.5	15	70	5
20	11x26	14x33	19x43	175	65	15	80	5
30	14x33	19x43	24x53	212	75	17	90	5
35	19x43	24x53	32x63	270	100	20	105	5
40	24x53	32x63	38x83	322	120	22	130	6
50	32x63	38x83	42x115	397	154	45	135	6
60	38x83	42x115	48x115	454	159	45	145	6
70	42x115	48x115	55x115	527	167	45	170	6

*Above Motor Adapter Flange and Input Keyway Dimensions are for reference only and depend on motor dimensions. Contact us to configure the appropriate adaptation for your specific motor.

*In lieu of standard coupling mounting system.

Mounting Options

Base Mounted Feet

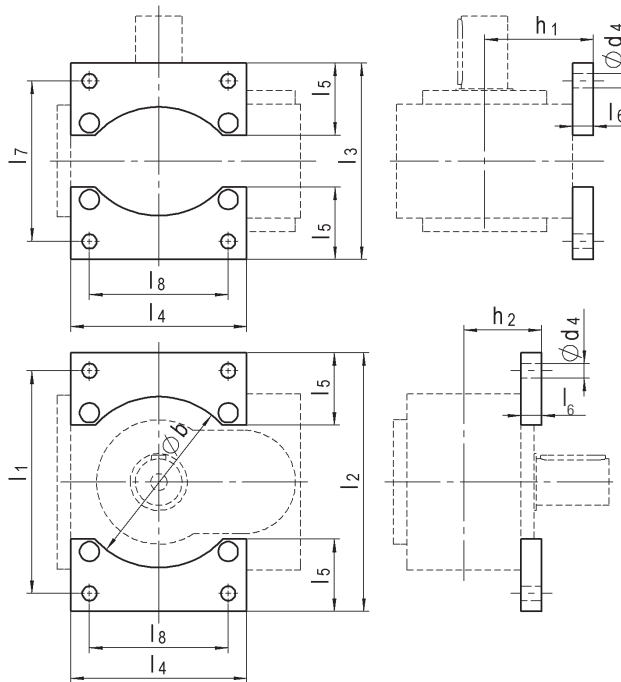

Frame Size	l1	l2	l3	l4	l5	l6	l7	l8	Øb	h1	h2	Ød4
10	146	168	136	110	50	17	114	88	108	72	54.4	9
20	178	208	158	140	60	20	128	110	135	90	65	11
30	215	250	190	170	70	20	155	134	165	105	75	14
35	265	310	240	210	90	25	195	170	205	130	95	18
40	295	345	275	240	100	30	225	190	235	150	115	18
50	335	385	315	280	100	30	265	220	275	170	135	18
60	430	480	360	360	125	30	310	280	350	210	150	22
70	520	580	410	450	140	30	350	350	440	255	170	22

Space Sleeves for Tapped Holes

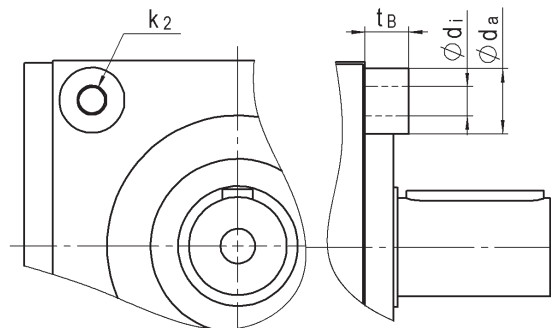
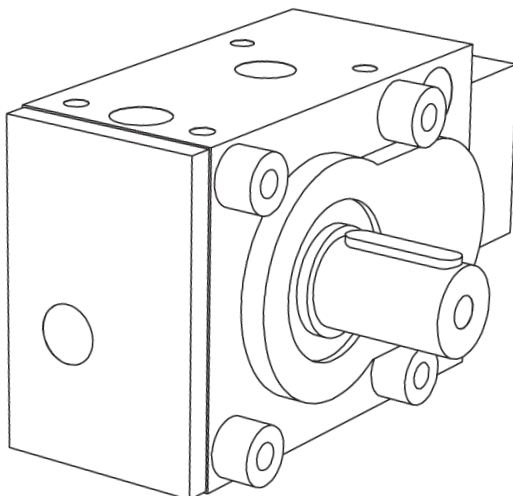

Frame Size	k2	di	da	tB
10	M8	9	20	15
20	M10	11	25	20
30	M12	13,5	30	20
35	M16	17,5	35	25
40	M16	17,5	35	25
50	M16	17,5	35	25
60	M20	22	45	30
70	M20	22	45	30

* Usable height of thread 1.5 x thread size.

Installation Information

Side Definition

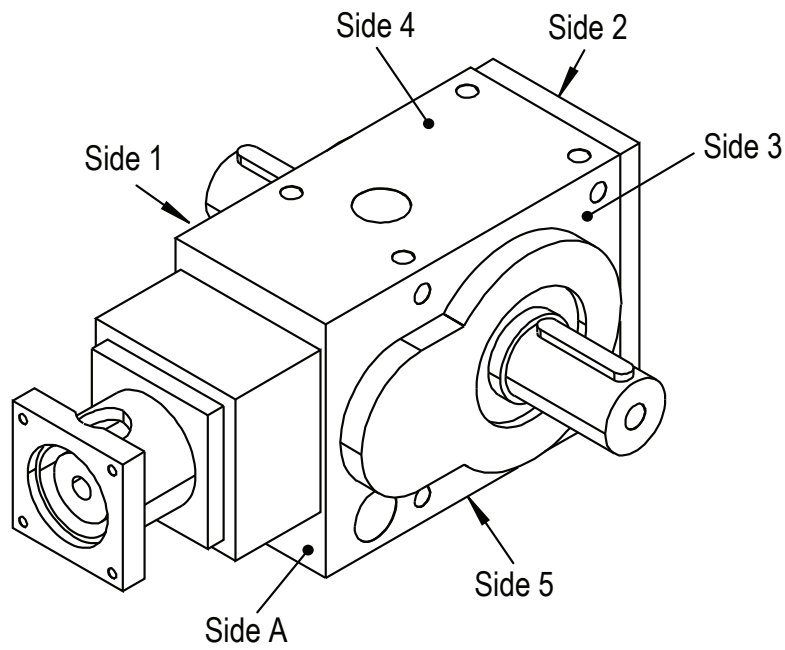

Mounting Positions

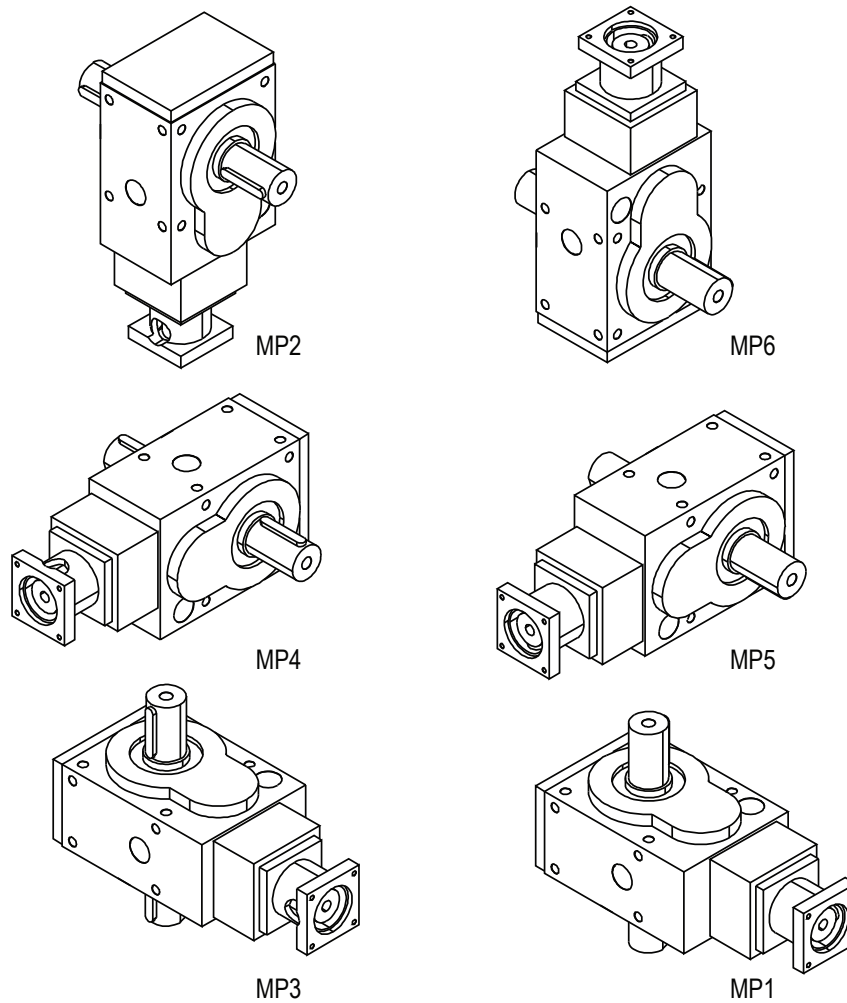

Gearbox Selection and Maintenance

Gearbox Selection Procedure

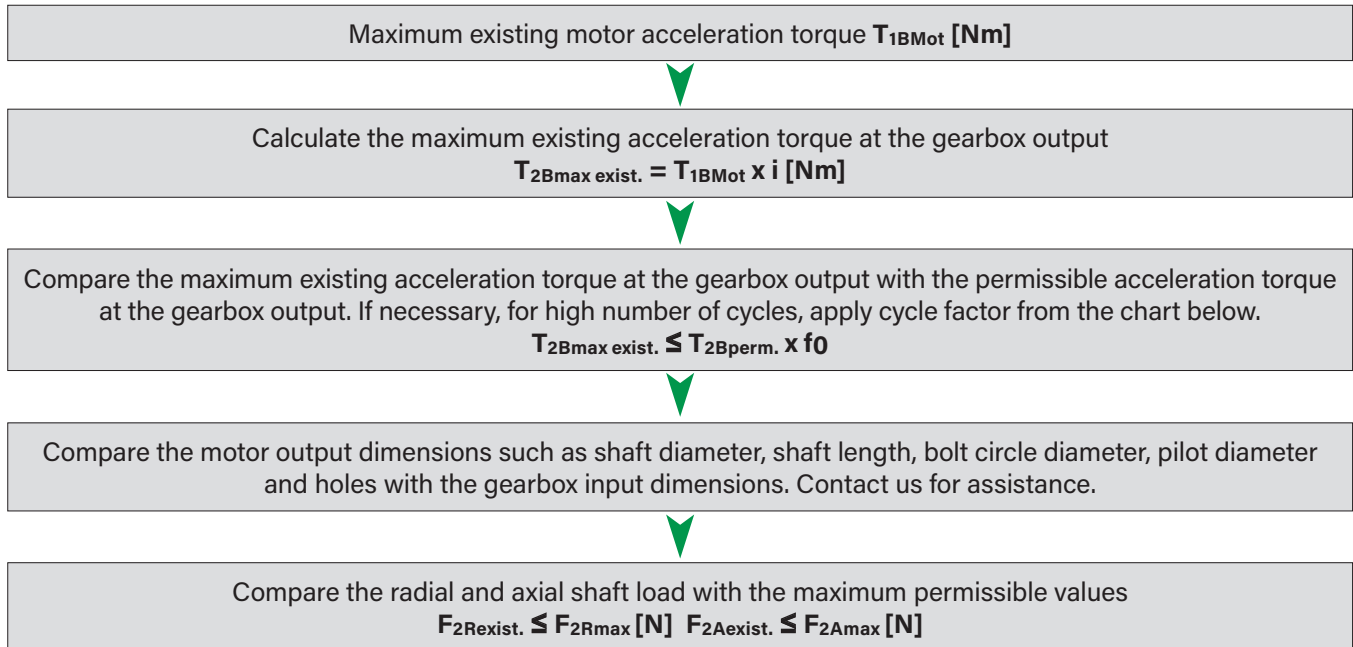

*Above selection is based on S5 cyclical duty cycle [DC] of <60% and run time [RT] < 20 min. Contact us for sizing assistance for S1 continuous operation.

Cycle Factor [f ₀]	<1,000 cycles/hour	1,000-3,000 cycles/hour	3,000-5,000 cycles/hour	5,000-7,000 cycles/hour
<1 hours/day	1.00	0.85	0.75	0.75
<8 hours/day	0.75	0.65	0.65	0.55
<16 hours/day	0.70	0.60	0.55	0.40
<24 hours/day	0.65	0.55	0.40	0.35

Gearbox Maintenance and Lubrication

Nidec Drive Technology Corporation TwinGear helical bevel gearboxes are supplied lubricated unless requested otherwise. For operating temperatures up to 80°C, we recommend the use of mineral hypoid gear oil API GL-4 to MIL-L-2105-A specification. For operating temperatures up to 95°C, we recommend the use of synthetic gear oils based on Poly-Alpha-Olefins (PAO) and for temperatures of up to 120°C, polyglycol-based synthetic gear oils to ISO VG-Class 150 (DIN 51519) or CLP DIN 51517 specification. In case of high temperatures, special seals must be specified.

The first oil change must be carried out after 500 operating hours. Draining the oil should take place immediately after the unit has been shut down, while the oil is still warm. Further oil changes are recommended every 5,000 operating hours and time intervals should not exceed 18 months. Oil drain plugs are fitted on all sides of the gearbox except the input side. Before re-filling, please ensure that all drain plugs have been inserted and tightened with the exception of the oil filling screw. In cases of doubt, please use new oil seals. When changing oil, we recommend that you fill the gear unit with the type of oil previously used. In particular, synthetic oils must not be mixed with mineral oils or other oil variants. When changing from mineral oil to synthetic oil, the gearbox must be rinsed thoroughly with the new oil type.

Upon request, gearboxes can be supplied with a lubricant indicator (oil sight glass, angular oil level indicator, oil dipstick). This requires details about mounting position and speed. Gearboxes without a lubricant indicator can be filled with the recommended average quantity of oil when speeds are low and the gearbox is installed pointing upwards. If the gearbox has a lubricant indicator, filling can be carried out precisely. The middle of the oil sight glass indicates the minimum fill level, whereas the maximum fill level is reached when an air bubble above the oil is still visible in the sight glass.

The condition of the gearbox, especially the leak tightness and the oil level must be checked regularly. Shaft seals which leak must be replaced to ensure operational safety. Please contact us for more detailed disassembly and lubrication instructions as well as lubricant options. Service kits with wear parts are available from our service department. Our products can also be sent back to the factory for inspection and lubrication.

Oil Quantities

Frame Size	10	20	30	35	40	50	60	70
Average Oil Quantity (liters)	0.3	0.6	1	1.9	3	5	9.5	21
Maximum Oil Capacity (liters)	0.4	0.75	1.5	2.7	4.5	6.5	13.5	32.5

* Oil quantity is dependent on ratio, speed, shaft arrangement and installation position.

POWERGEAR SERIES

PowerGear is a versatile, highly configurable and robust spiral bevel gearbox that fits a wide range of power transmission and motion control applications. Its modular design has numerous shaft configurations and driving orientations that can be adapted to any requirement—torque amplification, speed increase or reduction, inertia matching or turning a right angle to save space. All six sides of the gearbox can be used for mounting.

PowerGear frame sizes range from 27mm to 450mm, making it the only product that can go into small medical devices as well as large earth-moving machinery. PowerGear features the highest torque density in the industry ranging from 2.2Nm to 10,500Nm while staying 98% efficient. Mounting adapters are available for servo, stepper or AC induction motors. High speed, high torque, reduced backlash and cooling options are available for the most demanding duty cycles or environments.

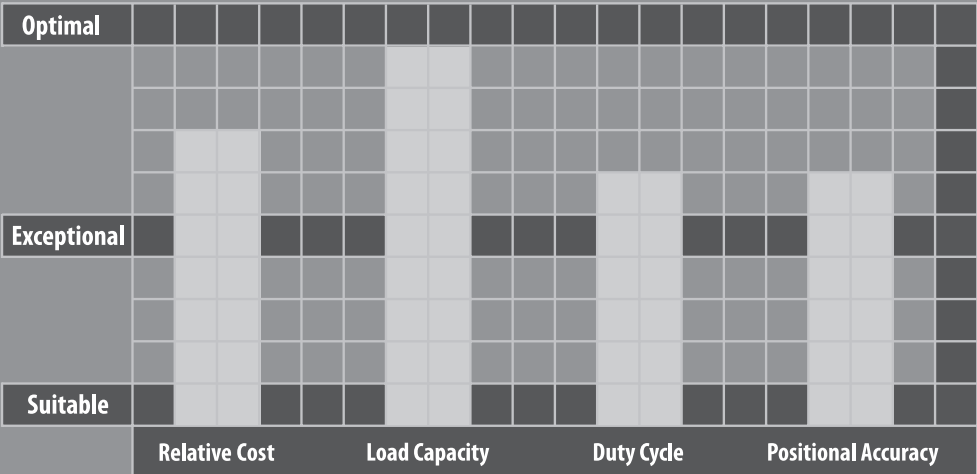



POWERGEAR SERIES

- Versatile spiral bevel gearboxes with numerous shaft configurations that can be oriented in any direction
- Compact, rigid design with reduction ratios as low as 1:1
- 15 Frame sizes with maximum acceleration torque up to 10,500Nm
- High torque, high speed and low backlash available as standard options for demanding applications
- High efficiency rating of 98% helps save on energy costs
- Assembled in Germany

Featured Highlights

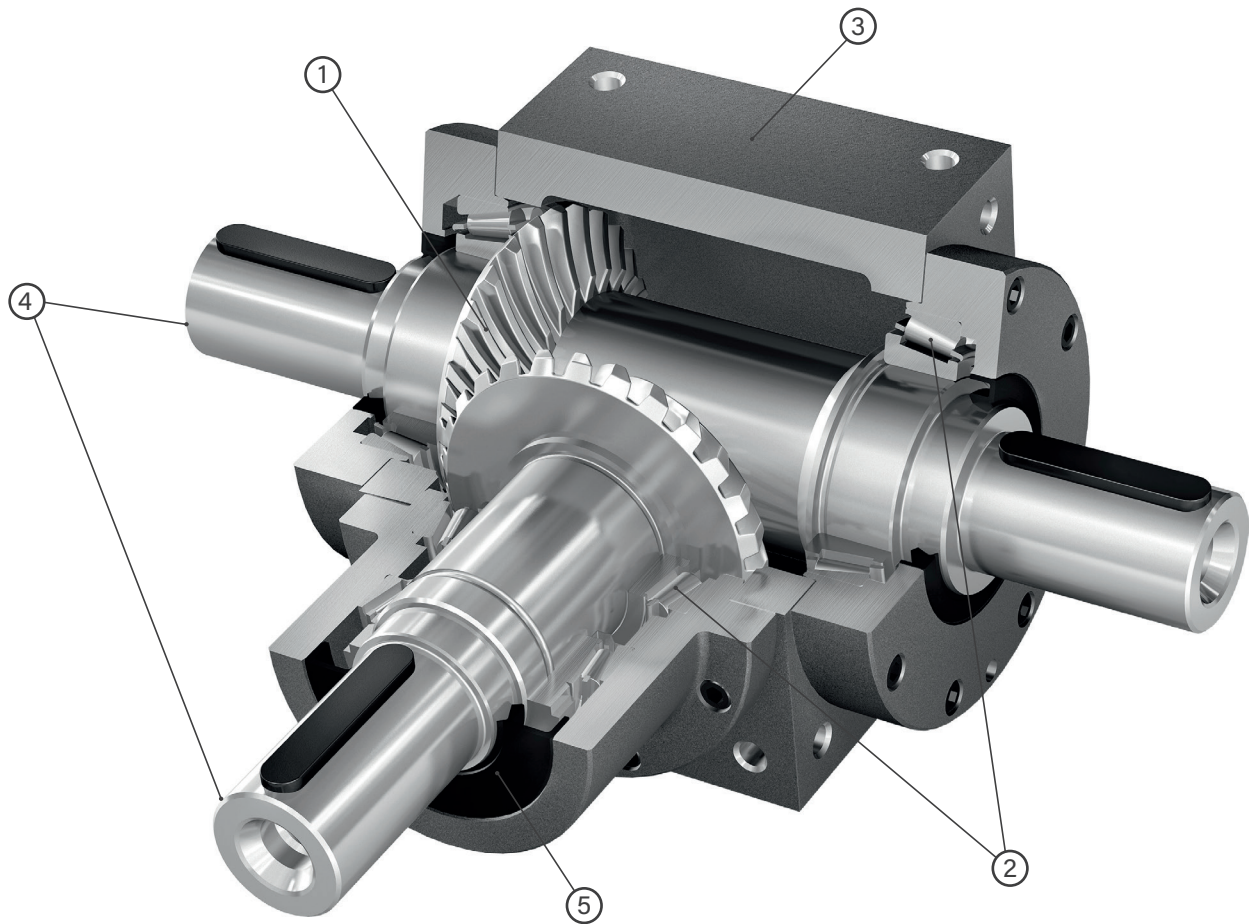

- ① Spiral bevel gears; precision cut, hardened and lapped for optimized contact pattern and uniform load distribution
- ② Tapered roller bearings at input and output for high radial and axial load capacity
- ③ Compact, rigid, ductile cast iron housing (aluminum for sizes 27-45). All six sides can be utilized for mounting
- ④ Numerous input and output shaft options available, including solid output, keyed hollow output, dual output or shrink disc. Input side can be shaft-in or motor-ready with adapter and coupling
- ⑤ NBR seals used for IP64 protection. Optional Viton seals available. Lubricated for life

Model Code

P	75	L	3	13L	XXX
Series Name	Frame Size	Mounting Type	Ratio	Shaft Arrangement	*Motor mounting code
P: PowerGear	27	L: Solid Shaft Input, Solid Shaft Output	1	Solid output:	Motor mounting code varies depending on the motor
PX: PowerGear High Torque	33		1.5	1L: Keyed Solid Shaft Left	
	45	H: Solid Shaft Input, Hollow Shaft Output	2	3L: Keyed Solid Shaft Right	
PS: PowerGear High Speed	54		3	13L: Keyed Dual Solid Shaft	
	65	FL: Motor Adapter and Coupling Input, Solid Shaft Output	4	12L: Keyed Solid Shaft Left with Solid Extension	
	75		5	23L: Keyed Solid Shaft Right with Solid Extension	
	90	FH: Motor Adapter and Coupling Input, Hollow Shaft Output		123L: Keyed Dual Solid Shaft with Solid Extension	
	110			Hollow output:	
	140			13L: Keyed Hollow Shaft	
	170			123L: Keyed Hollow Shaft with Solid Extension	
	210			Hollow Output with Shrink Disc Shaft (33-45 Only):	
	240			1LSV: Shrink Disc Shaft Right	
	280			3LSV: Shrink Disc Shaft Left	
	360			12LSV: Shrink Disc Shaft Right with Solid Extension	
	450			23LSV: Shrink Disc Shaft Left with Solid Extension	

* Motor mounting code varies depending on the motor. Contact us to configure the code.

* See page 37 for shaft arrangement detail.

* High Speed Option utilizes KL/KH mounting type codes in lieu of FL/FH codes.

* Frame sizes 27-54 have a more limited ratio offering. Check specifications section for ratio availability.

Performance Specifications

Frame Size	Unit	Note	Ratio	27	33	45	54	65	75	90	110
Nominal Output Torque	T2N [Nm]	*1	1:1	3.5	5	16	15	25	45	78	150
			1.5:1	2.2	3.2	11	15	25	45	78	150
			2:1	-	2.3	8.5	12	24	42	68	150
			3:1	-	1.5	6.5	12	18	33	54	120
			4:1	-	1.3	5	-	16	28	52	100
			5:1	-	-	-	-	14	25	40	85
Maximum Acceleration Torque	T2B [Nm]	*2	1:1	5	7.5	25	23	38	68	117	225
			1.5:1	3.3	4.8	16.5	23	38	68	117	225
			2:1	-	3.5	13	18	36	63	102	225
			3:1	-	2	10	18	27	50	81	180
			4:1	-	2	7.5	-	24	42	78	150
			5:1	-	-	-	-	21	38	60	128
Emergency Stop Torque	T2Not [Nm]	*3	1:1	7	10	32	30	50	90	156	300
			1.5:1	4.4	6.4	22	30	50	90	156	300
			2:1	-	4.6	17	24	48	84	136	300
			3:1	-	3	13	24	36	66	108	240
			4:1	-	2.6	10	-	32	56	104	200
			5:1	-	-	-	-	28	50	80	170
Nominal Input Speed	n1N [rpm]	*4	1:1	2500	2500	2500	2500	2150	2000	1700	1400
			1.5:1	3000	3000	3000	3000	2650	2500	2000	1600
			2:1	3000	3000	3000	3000	2650	2500	2000	1600
			3:1	3500	3500	3500	3500	3150	3000	2500	2100
			4:1	3500	3500	3500	3500	3150	3000	2500	2100
			5:1	3500	3500	3500	3500	3150	3000	2500	2100
Maximum Input Speed	n1max [rpm]	*5	-	7500	7500	7500	7500	7000	6500	5500	4500
Maximum Radial Load	F1Rmax [N]	*6	-	120	160	320	300	650	900	1300	2000
	F2Rmax [N]		-	150	200	400	400	800	1100	1600	2500
Maximum Axial Load	F1Amax [N]	*7	-	60	80	160	150	325	450	650	1000
	F2Amax [N]		-	75	100	200	200	400	550	800	1250
Moment of Inertia	I1 [kgcm ²]	*8	1:1	0.013	0.059	0.184	0.28	0.9	1.79	4.93	12.5
			1.5:1	0.008	0.037	0.092	0.15	0.59	1.22	3.45	9.17
			2:1	-	0.031	0.068	0.11	0.41	0.95	2.78	7.41
			3:1	-	0.026	0.051	0.09	0.31	0.78	2.34	6.18
			4:1	-	0.024	0.045	-	0.28	0.72	2.18	5.71
			5:1	-	-	-	-	0.26	0.69	2.1	5.48
Efficiency	h [%]	*9	-	> 98	> 98	> 98	> 98	> 98	> 98	> 98	> 98
Torsional Rigidity	Ct21 [Nm/arcmin]	*10	-	0.12	0.2	0.32	0.44	0.56	1.3	5	11
Maximum Backlash (Standard)	jt [arcmin]	*11	-	≤ 18	≤ 18	≤ 18	≤ 18	≤ 16	≤ 15	≤ 14	≤ 13
Maximum Backlash (Reduced)			-	-	-	-	≤ 12	≤ 10	≤ 9	≤ 8	≤ 8
Noise Level	LpA [dB(A)]	*12	-	≤ 70	≤ 70	≤ 70	≤ 70	≤ 70	≤ 70	≤ 74	≤ 76
Ambient Temperature	[°C]	-	-	-10 to 80							
Permitted Housing Temperature	[°C]	-	-	80							
Protection Class	-	-	-	IP64							
Lubrication	-	-	-	Synthetic Grease				Synthetic Oil [ISO VG-Class 150]			
Service Life	Lh [h]	*13	-	15,000							
Weight	m [kg]	-	-	0.16	0.22	0.55	1.8	3.9	4.5	8	13

Performance Specifications

Frame Size	Unit	Note	Ratio	140	170	210	240	280	360	450
Nominal Output Torque	T2N [Nm]	*1	1:1	360	585	1300	2150	3200	3750	6600
			1.5:1	360	585	1300	2150	3200	3550	7000
			2:1	330	544	1220	2010	3050	3500	7000
			3:1	270	450	1020	1650	2850	3350	7000
			4:1	224	376	860	1410	2300	2900	6600
Maximum Acceleration Torque	T2B [Nm]	*2	1:1	540	878	1950	3225	4800	5625	9900
			1.5:1	540	878	1950	3225	4800	5325	10500
			2:1	495	816	1830	3015	4575	5250	10500
			3:1	405	675	1530	2475	4275	5025	10500
			4:1	336	564	1290	2115	3450	4350	9900
Emergency Stop Torque	T2Not [Nm]	*3	1:1	720	1170	2600	4300	6400	7500	13200
			1.5:1	720	1170	2600	4300	6400	7100	14000
			2:1	660	1088	2440	4020	6100	7000	14000
			3:1	540	900	2040	3300	5700	6700	14000
			4:1	448	752	1720	2820	4600	5800	13200
Nominal Input Speed	n1N [rpm]	*4	1:1	1100	1000	800	700	650	650	550
			1.5:1	1400	1300	1050	950	850	850	800
			2:1	1400	1300	1050	950	850	850	800
			3:1	2000	1800	1600	1350	1200	1200	1100
			4:1	2000	1800	1600	1350	1200	1200	1100
Maximum Input Speed	n1max [rpm]	*5	-	3500	3000	2200	2000	1700	1400	1300
	F1Rmax [N]	*6	-	3500	5000	8500	11000	15000	*14	*14
Maximum Radial Load	F2Rmax [N]		-	4500	6000	10500	15000	18000	24000	34000
Maximum Axial Load	F1Amax [N]	*7	-	1750	2500	4250	5500	7500	*14	*14
	F2Amax [N]		-	2250	3000	5250	7500	9000	12000	17000
Moment of Inertia	I1 [kgcm ²]	*8	1:1	36.8	85.9	287	592	1190	2314	7632
			1.5:1	22.4	54.6	179	373	762	1270	4152
			2:1	15.6	39.3	123	253	506	877	2764
			3:1	10.9	28.5	84.1	167	328	467	1596
			4:1	9.19	24.5	69.9	136	263	316	1077
Efficiency	h [%]	*9	-	> 98	> 98	> 98	> 98	> 98	> 98	> 98
			Torsional Rigidity	Ct21 [Nm/arcmin]	*10	-	24	43	92	137
Maximum Backlash (Standard)	jt [arcmin]	*11	-	≤ 12	≤ 12	≤ 11	≤ 11	≤ 11	≤ 11	≤ 10
Maximum Backlash (Reduced)			-	≤ 7	≤ 6	≤ 6	≤ 6	≤ 6	≤ 6	≤ 5
Noise Level	LpA [dB(A)]	*12	-	≤ 77	≤ 78	≤ 80	≤ 82	≤ 83	≤ 85	≤ 85
Ambient Temperature	[°C]	-	-	-10 to 80						
Permitted Housing Temperature	[°C]	-	-	80						
Protection Class	-	-	-	IP64						
Lubrication	-	-	-	Synthetic Oil [ISO VG-Class 150]						
Service Life	Lh [h]	*13	-	15,000						
Weight	m [kg]	-	-	22	38.5	71	103.5	155	240	400

*1 At nominal input speed, service life is 15,000 hours.

*2 The maximum torque when starting or stopping operation. Permitted 1,000 cycles/hour.

*3 The maximum torque allowed under a stress situation. Permitted 1,000 times during service life.

*4 The average input speed applied at 20% of nominal output torque at 20°C ambient temperature.

*5 The maximum intermittent input speed.

*6 Maximum radial load gearbox can accept. Measured at center of output shaft at 400rpm.

*7 Maximum axial load gearbox can accept. Measured at center of output shaft at 400rpm.

*8 Based on solid input shaft and dual solid output shaft.

*9 The efficiency at full load.

*10 At nominal output torque. Does not include lost motion.

*11 Measured at output, 2% load and max 10Nm.

*12 Measured at 1,500 rpm input at partial load.

*13 Based on S5 duty cycle <60% and <20 minute run time.

*14 Maximum radial and axial load ratings dependent on ratio. Contact us for values.

Performance Specifications

High Torque Option

Frame Size	Unit	Note	54	75	90	110	140	170	210	240	280
Ratio	i		1:1								
Nominal Output Torque	T2N [Nm]	*1	24	87	135	290	625	1020	2050	3350	5200
Maximum Acceleration Torque	T2B [Nm]	*2	36	131	203	435	938	1530	3075	5025	7800
Emergency Stop Torque	T2Not [Nm]	*3	48	174	270	580	1250	2040	4100	6700	10400
Nominal Input Speed	n1N [rpm]	*4	2500	2000	1700	1400	1100	1000	800	700	650
Maximum Input Speed	n1max [rpm]	*5	4000	3000	2500	2000	2000	1500	1200	1200	1000
Maximum Radial Load	F1Rmax [N]	*6	400	1500	2000	3500	5500	7800	12000	16000	20000
	F2Rmax [N]		600	2000	2700	4500	7500	11000	16000	21000	30000
Maximum Axial Load	F1Amax [N]	*7	200	750	1000	1750	2750	3900	6000	8000	10000
	F2Amax [N]		300	1000	1350	2250	3750	5500	8000	10500	15000
Moment of Inertia	I1 [kgcm ²]	*8	0.34	2.26	5.99	21.4	61.3	142	485	987	2150
Efficiency	h [%]	*9	> 98	> 98	> 98	> 98	> 98	> 98	> 98	> 98	> 98
Torsional Rigidity	Ct21 [Nm/arcmin]	*10	0.3	1	4	10	20	34	46	54	120
Maximum Backlash (Standard)	jt [arcmin]	*11	≤ 18	≤ 15	≤ 14	≤ 13	≤ 12	≤ 12	≤ 11	≤ 11	≤ 11
Maximum Backlash (Reduced)			≤ 12	≤ 9	≤ 8	≤ 8	≤ 7	≤ 6	≤ 6	≤ 6	≤ 6
Noise Level	LpA [dB(A)]	*12	≤ 70	≤ 70	≤ 74	≤ 76	≤ 77	≤ 78	≤ 80	≤ 82	≤ 83
Ambient Temperature	[°C]	-	-10 to 80								
Permitted Housing Temperature	[°C]	-	80								
Protection Class	-	-	IP64								
Lubrication	-	-	Synthetic Oil [ISO VG-Class 150]								
Service Life	Lh [h]	*13	15,000								
Weight	m [kg]	-	1.9	5	8.5	13.5	22.5	39	71.5	104	155.5

- *1 At nominal input speed, service life is 15,000 hours.
- *2 The maximum torque when starting or stopping operation. Permitted 1,000 cycles/hour.
- *3 The maximum torque allowed under a stress situation. Permitted 1,000 times during service life.
- *4 The average input speed applied at 20% of nominal output torque at 20°C ambient temperature.
- *5 The maximum intermittent input speed.
- *6 The maximum radial load the gearbox can accept. Measured at center of output shaft at 400rpm output.
- *7 The maximum axial load the gearbox can accept. Measured at center of output shaft at 400rpm output.
- *8 Based on solid input shaft and dual solid output shaft.
- *9 The efficiency at full load.
- *10 At nominal output torque. Does not include lost motion.
- *11 Measured at output, 2% load and max 10Nm.
- *12 Measured at 1,500 rpm input at partial load.
- *13 Based on S5 duty cycle <60% and <20 minute run time.

Performance Specifications

High Speed Option

Frame Size	Unit	Note	Ratio	75	90	110	140	170
Nominal Output Torque	T2N [Nm]	*1	1:1	25	45	78	150	360
			1.5:1	25	45	78	150	360
			2:1	24	42	68	150	330
Maximum Acceleration Torque	T2B [Nm]	*2	1:1	38	68	117	225	540
			1.5:1	38	68	117	225	540
			2:1	36	63	102	225	495
Emergency Stop Torque	T2Not [Nm]	*3	1:1	50	90	156	300	720
			1.5:1	50	90	156	300	720
			2:1	48	84	136	300	660
Nominal Input Speed	n1N [rpm]	*4	1:1	3300	3000	2800	2500	2000
			1.5:1	4000	3500	3200	3000	2600
			2:1	4000	3500	3200	3000	2600
Maximum Input Speed	n1max [rpm]	*5	-	8500	8500	7000	5500	4000
Maximum Radial Load	F1Rmax [N]	*6	-	650	900	1300	2000	3500
	F2Rmax [N]		-	800	1100	1600	2500	4500
Maximum Axial Load	F1Amax [N]	*7	-	325	450	650	1000	1750
	F2Amax [N]		-	400	550	800	1250	2250
Moment of Inertia	I1 [kgcm ²]	*8	1:1	0.73	1.33	3.88	9.26	31.6
			1.5:1	0.49	0.95	2.88	6.31	19.6
			2:1	0.38	0.77	2.38	4.6	13.8
Efficiency	h [%]	*9	-	> 98	> 98	> 98	> 98	> 98
Torsional Rigidity	Ct21 [Nm/arcmin]	*10	-	0.2	0.5	2	5	10
Maximum Backlash (Standard)	jt [arcmin]	*11	-	≤ 16	≤ 15	≤ 14	≤ 13	≤ 12
Maximum Backlash (Reduced)			-	≤ 10	≤ 9	≤ 8	≤ 8	≤ 7
Noise Level	LpA [dB(A)]	*12	-	≤ 70	≤ 70	≤ 74	≤ 76	≤ 77
Ambient Temperature	[°C]	-	-	-10 to 100				
Permitted Housing Temperature	[°C]	-	-	100				
Protection Class	-	-	-	IP64				
Lubrication	-	-	-	Synthetic Oil [ISO VG-Class 150]				
Service Life	Lh [h]	*13	-	15,000				
Weight	m [kg]	-	-	3.9	4.5	8	13	22

*1 At nominal input speed, service life is 15,000 hours.

*2 The maximum torque when starting or stopping operation. Permitted 1,000 cycles/hour.

*3 The maximum torque allowed under a stress situation. Permitted 1,000 times during service life.

*4 The average input speed applied at 20% of nominal output torque at 20°C ambient temperature.

*5 The maximum intermittent input speed.

*6 The maximum radial load the gearbox can accept. Measured at center of output shaft at 400rpm output.

*7 The maximum axial load the gearbox can accept. Measured at center of output shaft at 400rpm output.

*8 Based on solid input shaft and dual solid output shaft.

*9 The efficiency at full load.

*10 At nominal output torque. Does not include lost motion.

*11 Measured at output, 2% load and max 10Nm.

*12 Measured at 1,500 rpm input at partial load.

*13 Based on S5 duty cycle <60% and <20 minute run time.

Dimensions and Configurations

Solid Shaft Input, Solid Shaft Output, Sizes 27-45

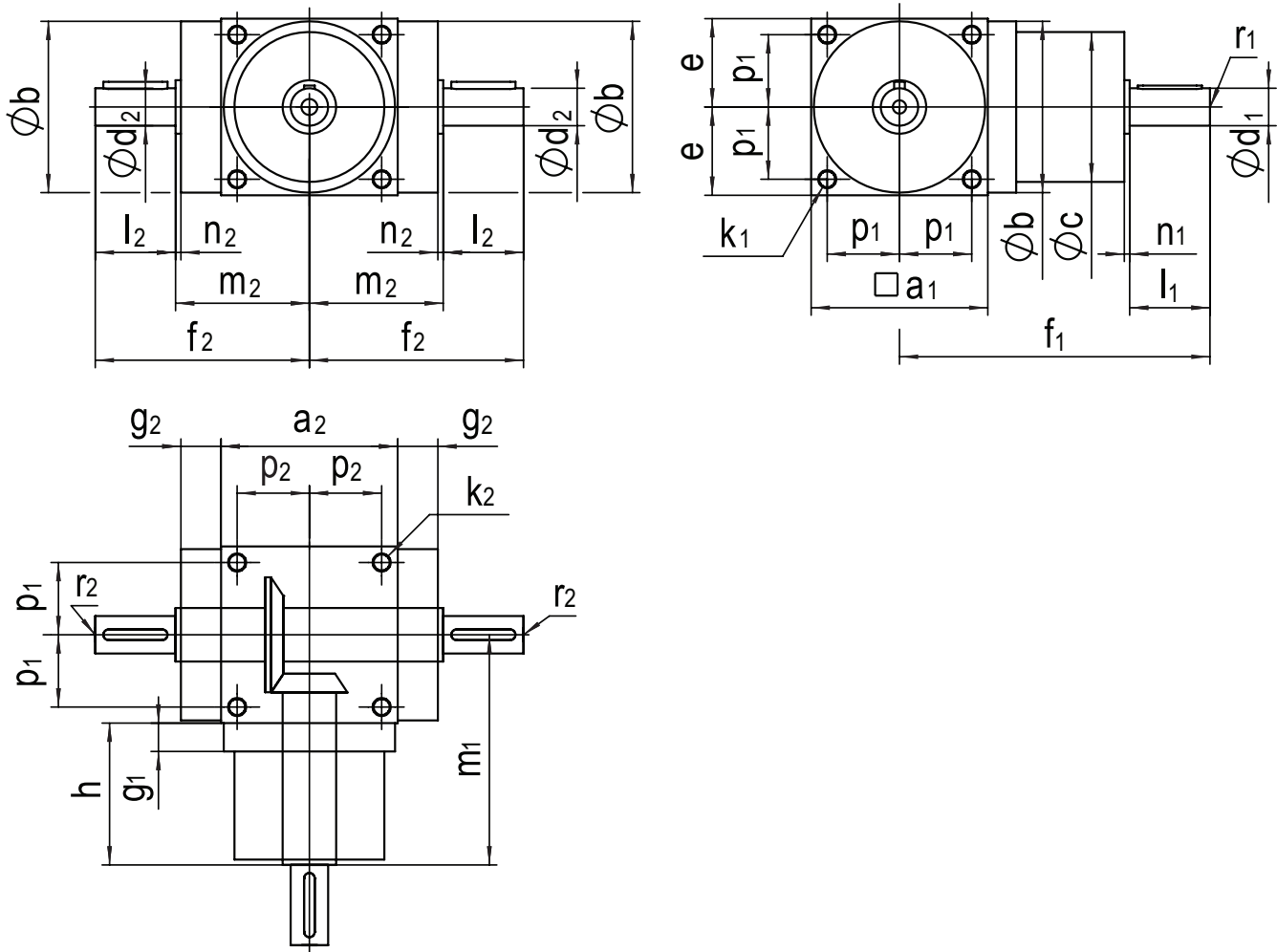

Frame Size	a1	a2	$\varnothing b$ h7	$\varnothing c$	$\varnothing d_1$ k6	l1	$\varnothing d_2$ k6	l2	e	f1	f2	g1	g2
27	27	37	26	25	6	13	6	13	13.5	51	35.5	4.5	3
33	33	33	32	28	7	15	7	15	16.5	58	40	4.5	7.5
45	45	33	44	43	10	23	10	23	22.5	78	58	8.2	11.5

Frame Size	h	k	m1	m2	n1	n2	p1	p2	r1	r2	d1 key	d2 key
27	24.5	M3x3.5	38	22.5	1	1	11	12.5	M2	M2	2x2x10	2x2x10
33	26.5	M3x4	43	25	1	1	13.5	13.5	M3	M3	2x2x12	2x2x12
45	32.5	M4x5.5	55	35	1	1	18.5	18.5	M3	M3	3x3x18	3x3x18

* Thread depth for dimension k starts from 4 mm, 4.5 mm and 6 mm for frame sizes 27, 33, 45 respectively.

Dimensions and Configurations

Solid Shaft Input, Hollow Shaft Output with Shrink Disc Extension, Sizes 33-45

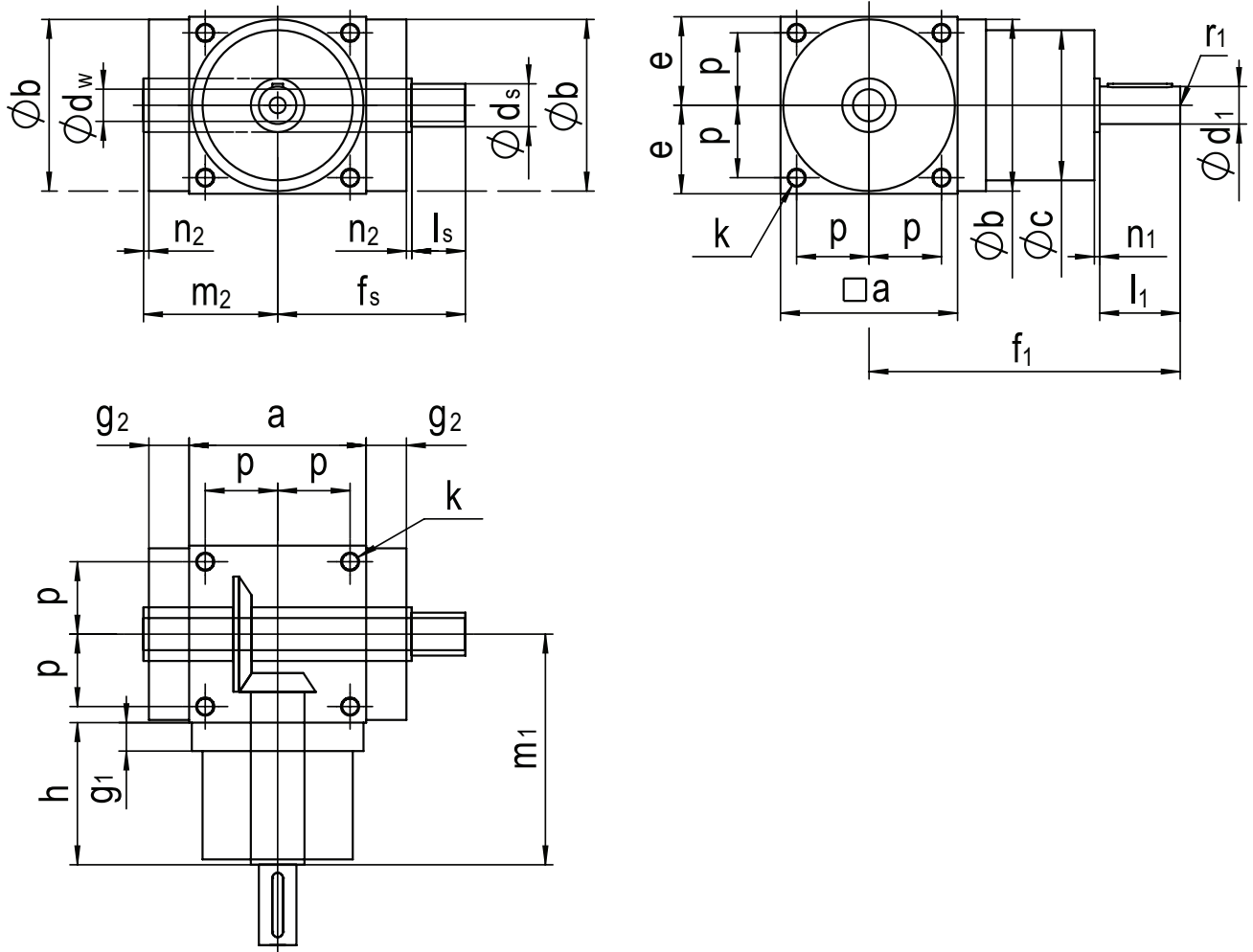

Frame Size	a	$\varnothing b$ h7	$\varnothing c$	$\varnothing d_1$ k6	l1	$\varnothing d_w$ H7	$\varnothing d_s$ j6	l _s	e	f ₁	f _s	g ₁	g ₂
33	33	32	28	7	15	6	8	10	16.5	58	35	4.5	7.5
45	45	44	43	10	23	10	12	15	22.5	78	50	8.2	11.5

Frame Size	h	k	m ₁	m ₂	n ₁	n ₂	p	r ₁	d ₁ key
33	26.5	M3x4	43	25	1	1	13.5	M3	2x2x12
45	32.5	M4x5.5	55	35	1	1	18.5	M3	3x3x18

* Thread depth for dimension k starts from 4.5 mm and 6 mm for frame sizes 33, 45 respectively.

Dimensions and Configurations

Solid Shaft Input, Solid Shaft Output, Sizes 54-280

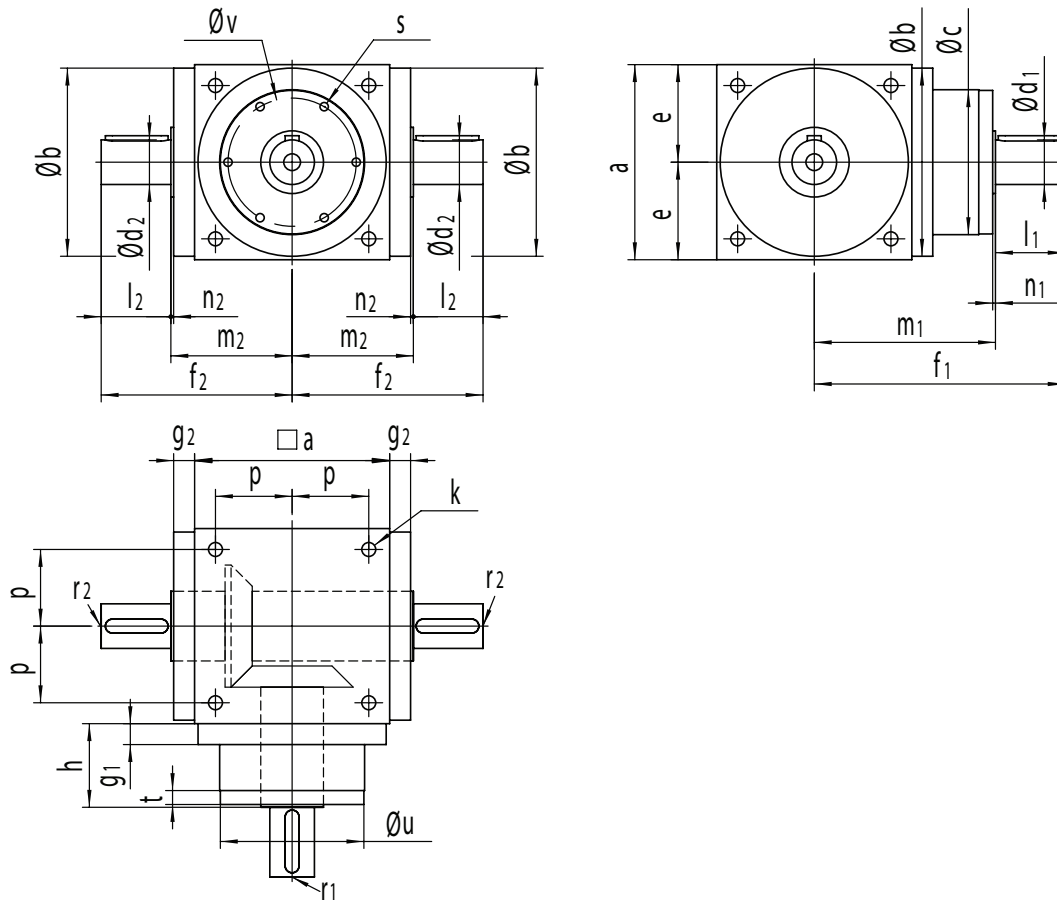

Frame Size	a	$\varnothing b$ h7	$\varnothing c$	$\varnothing d_1$ k6	l1	$\varnothing d_2$ k6	l2	e	f1	f2	g1	g2	h	k
54	54	53	53	11	23	11	23	27	95	60	43	9	45	M5x14.5
65	65	64	63	12	26	12	26	32.5	100	72	9.5	11.5	41.5	M5x12
75	75	73	72	16	30	16	30	37.5	120	84	15	14.5	52.5	M6x12
90	90	88	86	18	35	18	35	45	135	97	15	15	55	M6x12
110	110	108	106	22	40	22	40	55	155	112	15	15	60	M8x15.5
140	140	135	104	32	50	32	50	70	180	137	15	15	60	M10x19.5
170	170	165	128	40	60	40	60	85	215	162	15	15	70	M12x23
210	210	205	160	50	75	50	75	105	265	202	20	20	85	M16x30
240	240	235	180	55	85	55	85	120	300	232	25	25	95	M16x30
280	280	275	200	60	110	60	110	140	360	277	25	25	110	M16x30

Frame Size	m1	m2	n1	n2	p	r1	r2	s	t	$\varnothing u$ g6	$\varnothing v$	d1 key	d2 key
54	72	37	2	1	22	M4	M4	-	-	-	-	4x4x18	4x4x18
65	74	46	2	2	26	M4	M4	4xM5x9	8	63.9	54	4x4x20	4x4x20
75	90	54	2	2	30	M5	M5	4xM5x9	8	72.9	62	5x5x25	5x5x25
90	100	62	2	2	36	M6	M6	4xM5x12	8	87	76	6x6x28	6x6x28
110	115	72	2	2	44	M8	M8	6xM6x12	8	107	92	6x6x32	6x6x32
140	130	87	2	2	55	M12	M12	6xM6x12	10	103	92	10x8x45	10x8x45
170	155	102	2	2	67	M16	M16	6xM8x14	10	127	114	12x8x50	12x8x50
210	190	127	2	2	85	M16	M16	6xM8x14	10	158	142	14x9x70	14x9x70
240	215	147	2	2	95	M20	M20	6xM8x14	10	178	160	16x10x80	16x10x80
280	250	167	2	2	110	M20	M20	6xM10x17	10	198	176	18x11x100	18x11x100

* Thread depth for dimension k starts from 7 mm for frame size 54.

Dimensions and Configurations

Solid Shaft Input, Hollow Shaft Output, Sizes 65-280

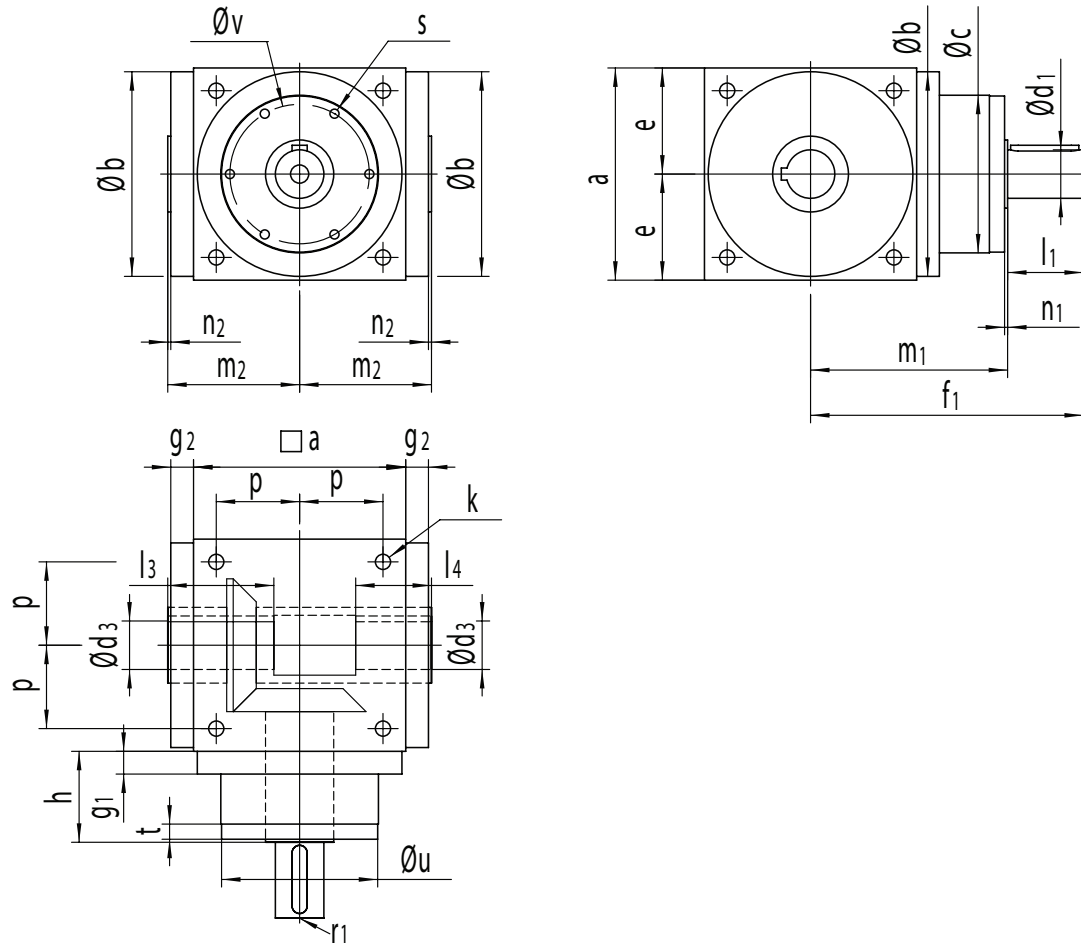

Frame Size	a	Øb h7	Øc	Ød1 k6	l1	Ød3 H7	l3	l4	e	f1	g1	g2	h	k
65	65	64	63	12	26	12	40	28	32.5	100	9.5	11.5	41.5	M5x12
75	75	73	72	16	30	14	47	32	37.5	120	15	14.5	52.5	M6x12
90	90	88	86	18	35	18	55	35	45	135	15	15	55	M6x12
110	110	108	106	22	40	22	60	40	55	155	15	15	60	M8x15.5
140	140	135	104	32	50	32	70	50	70	180	15	15	60	M10x19.5
170	170	165	128	40	60	40	80	55	85	215	15	15	70	M12x23
210	210	205	160	50	75	50	95	65	105	265	20	20	85	M16x30
240	240	235	180	55	85	55	115	80	120	300	25	25	95	M16x30
280	280	275	200	60	110	60	130	80	140	360	25	25	110	M16x30

Frame Size	m1	m2	n1	n2	p	r1	s	t	Øu g6	Øv	d1 key	d3 keyway
65	74	46	2	2	26	M4	4xM5x9	8	63.9	54	4x4x20	4x4
75	90	54	2	2	30	M5	4xM5x9	8	72.9	62	5x5x25	5x5
90	100	62	2	2	36	M6	4xM5x12	8	87	76	6x6x28	6x6
110	115	72	2	2	44	M8	6xM6x12	8	107	92	6x6x32	6x6
140	130	87	2	2	55	M12	6xM6x12	10	103	92	10x8x45	10x8
170	155	102	2	2	67	M16	6xM8x14	10	127	114	12x8x50	12x8
210	190	127	2	2	85	M16	6xM8x14	10	158	142	14x9x70	14x9
240	215	147	2	2	95	M20	6xM8x14	10	178	160	16x10x80	16x10
280	250	167	2	2	110	M20	6xM10x17	10	198	176	18x11x100	18x11

Dimensions and Configurations

Motor Adapter and Coupling Input, Solid Shaft Output, Sizes 75-280

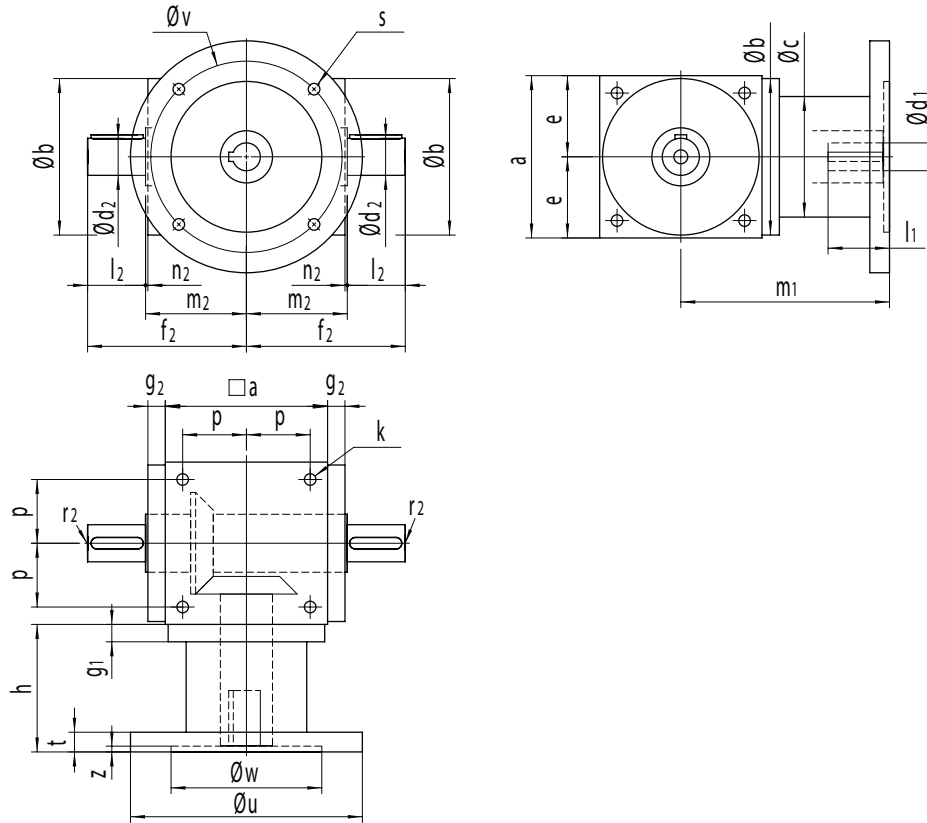

Frame Size	a	Øb h7	Øc	Ød2 k6	l2	e	f2	g1	g2	h
75	75	73	72	16	30	37.5	84	15	14.5	62.5
90	90	88	86	18	35	45	97	15	15	68
110	110	108	106	22	40	55	112	15	15	80
140	140	135	104	32	50	70	137	15	15	110
170	170	165	128	40	60	85	162	15	15	130
210	210	205	160	50	75	105	202	20	20	170
240	240	235	180	55	85	120	232	25	25	180
280	280	275	200	60	110	140	277	25	25	185

Frame Size	k	m1	m2	n2	p	r2	t	d2 key	z
75	M6x12	102	54	2	30	M5	14	5x5x25	4.5
90	M6x12	113	62	2	36	M6	14	6x6x28	4.5
110	M8x15.5	135	72	2	44	M8	17	6x6x32	5
140	M10x19.5	180	87	2	55	M12	17	10x8x45	5
170	M12x23	215	102	2	67	M16	20	12x8x50	6
210	M16x30	275	127	2	85	M16	20	14x9x70	6
240	M16x30	300	147	2	95	M20	20	16x10x80	6
280	M16x30	325	167	2	110	M20	20	18x11x100	6

Motor Adapter Flange and Coupling Dimensions

Frame Size	Øu x Øv x s x Øw (B5 motor adapter)				Øu x Øv x s x Øw (B12 motor adapter)				Ød1G7 x l1 / Keyway w x h (Coupling)		
75	120x100x6x80	140x115x8x95	160x130x8x110	200x165x10x130	120x100x6.6x80	140x115x9x95	160x130x9x110	200x165x11x130	14x33/5x5	-	-
90	120x100x6x80	140x115x8x95	160x130x8x110	200x165x10x130	-	140x115x9x95	160x130x9x110	200x165x11x130	14x33/5x5	19x43/6x6	-
110	120x100x6x80	140x115x8x95	160x130x8x110	200x165x10x130	-	-	160x130x9x110	200x165x11x130	19x43/6x6	24x53/8x7	-
140	160x130x8x110	200x165x10x130	250x215x12x180	300x265x12x230	-	-	160x130x9x110	200x165x11x130	24x53/8x7	28x63/8x7	32x63/10x8
170	200x165x10x130	250x215x12x180	300x265x12x230	350x300x16x250	-	-	-	200x165x11x130	28x63/8x7	32x83/10x8	38x83/10x8
210	-	250x215x12x180	300x265x12x230	350x300x16x250	-	-	-	-	38x83/10x8	42x115/12x8	48x115/14x9
240	250x215x12x180	300x265x12x230	350x300x16x250	400x350x16x300	-	-	-	-	38x83/10x8	42x115/12x8	48x115/14x9
280	300x265x12x230	350x300x16x250	400x350x16x300	450x400x16x350	-	-	-	-	48x115/14x9	55x115/16x10	-

* Above Motor Adapter Flange and Coupling Dimensions are for common reference only and depend on motor dimensions. Contact us to configure adaptation for your specific motor.

Dimensions and Configurations

Motor Adapter and Coupling Input, Hollow Shaft Output, Sizes 75-280

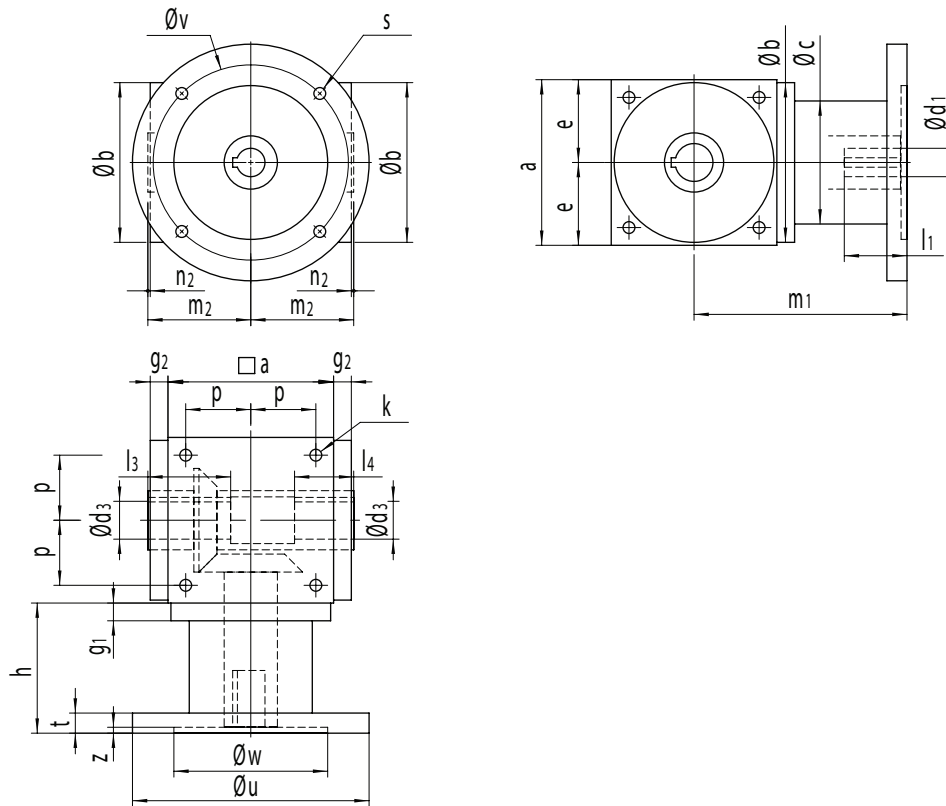

Frame Size	a	Øbh7	Øc	Ød3H7	e	g1	g2	h	k
75	75	73	72	14	37.5	15	14.5	62.5	M6x12
90	90	88	86	18	45	15	15	68	M6x12
110	110	108	106	22	55	15	15	80	M8x15.5
140	140	135	104	32	70	15	15	110	M10x19.5
170	170	165	128	40	85	15	15	130	M12x23
210	210	205	160	50	105	20	20	170	M16x30
240	240	235	180	55	120	25	25	180	M16x30
280	280	275	200	60	140	25	25	185	M16x30

Frame Size	l3	l4	m1	m2	n2	p	t	d3 key	z
75	47	32	102	54	2	30	14	5x5	4.5
90	55	35	113	62	2	36	14	6x6	4.5
110	60	40	135	72	2	44	17	6x6	5
140	70	50	180	87	2	55	17	10x8	5
170	80	55	215	102	2	67	20	12x8	6
210	95	65	275	127	2	85	20	14x9	6
240	115	80	300	147	2	95	20	16x10	6
280	130	80	325	167	2	110	20	18x11	6

Motor Adapter Flange and Coupling Dimensions

Frame Size	Øu x Øv x s x Øw (B5 motor adapter)				Øu x Øv x s x Øw (B12 motor adapter)				Ød1G7 x l1 / Keyway w x h (Coupling)		
75	120x100x6x80	140x115x8x95	160x130x8x110	200x165x10x130	120x100x6,6x80	140x115x9x95	160x130x9x110	200x165x11x130	14x33/5x5	-	-
90	120x100x6x80	140x115x8x95	160x130x8x110	200x165x10x130	-	140x115x9x95	160x130x9x110	200x165x11x130	14x33/5x5	19x43/6x6	-
110	120x100x6x80	140x115x8x95	160x130x8x110	200x165x10x130	-	-	160x130x9x110	200x165x11x130	19x43/6x6	24x53/8x7	-
140	160x130x8x110	200x165x10x130	250x215x12x180	300x265x12x230	-	-	160x130x9x110	200x165x11x130	24x53/8x7	28x63/8x7	32x63/10x8
170	200x165x10x130	250x215x12x180	300x265x12x230	350x300x16x250	-	-	-	200x165x11x130	28x63/8x7	32x83/10x8	38x83/10x8
210	-	250x215x12x180	300x265x12x230	350x300x16x250	-	-	-	-	38x83/10x8	42x115/12x8	48x115/14x9
240	250x215x12x180	300x265x12x230	350x300x16x250	400x350x16x300	-	-	-	-	38x83/10x8	42x115/12x8	48x115/14x9
280	300x265x12x230	350x300x16x250	400x350x16x300	450x400x16x350	-	-	-	-	48x115/14x9	55x115/16x10	-

* Above Motor Adapter Flange and Coupling Dimensions are for common reference only and depend on motor dimensions. Contact us to configure adaptation for your specific motor.

Dimensions and Configurations

Solid Shaft Input, Solid Shaft Output, Sizes 360-450

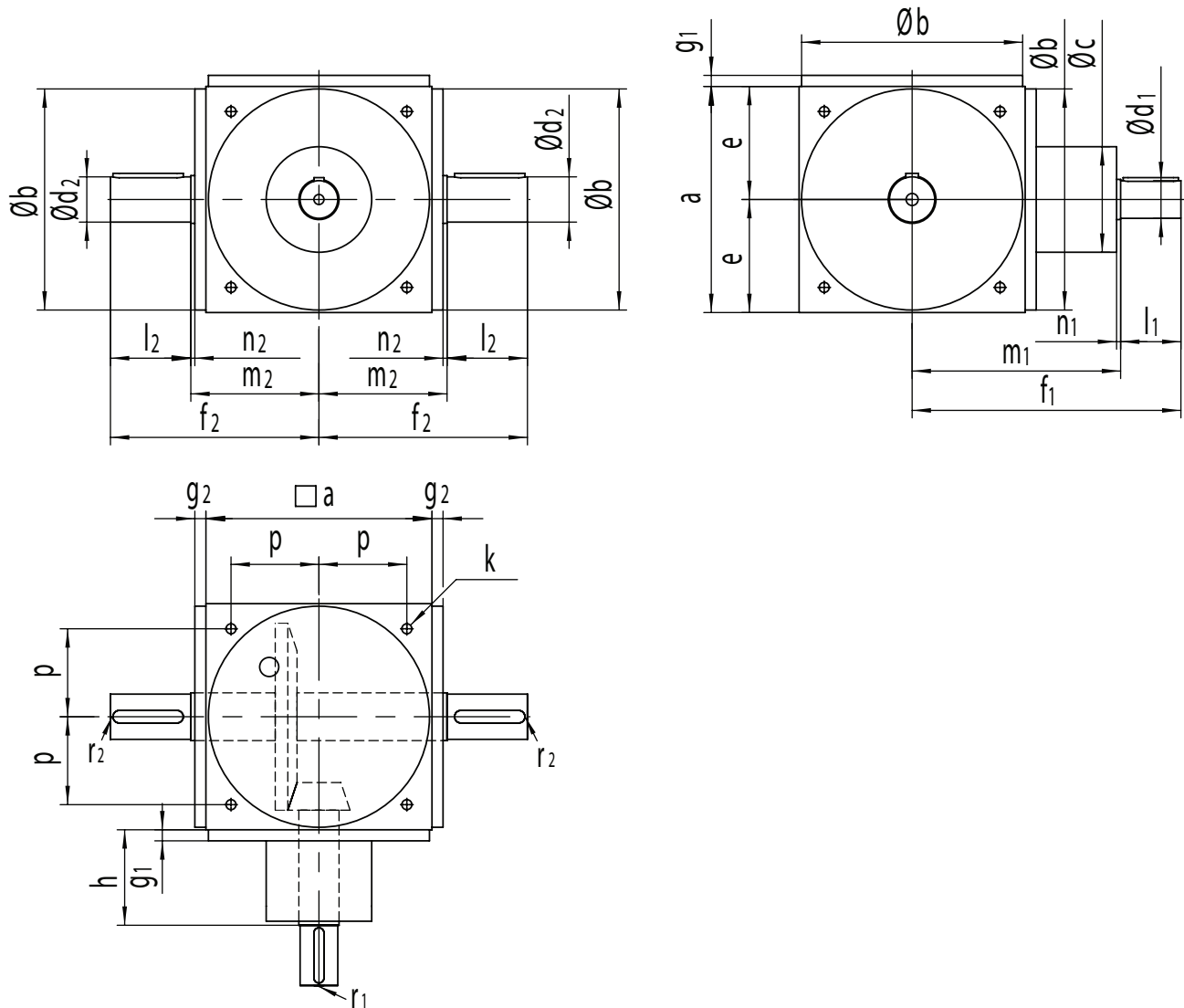

Frame Size	a	$\varnothing b$ h7	$\varnothing c$		$\varnothing d_1$ k6				l1			$\varnothing d_2$ k6	
Ratio	1:1 - 5:1	1:1 - 5:1	1:1 - 2:1	3:1 - 5:1	1:1 - 2:1	3:1	4:1	5:1	1:1 - 2:1	3:1	4:1	5:1	1:1 - 5:1
360	360	350	210	170	75	60	55	50	120	110	85	80	75
450	450	440	250	210	90	75	70	60	160	120	120	110	90

Frame Size	l2	e	f1				f2	g1	g2	h	k	m1	m2
Ratio	1:1 - 5:1	1:1 - 5:1	1:1 - 2:1	3:1	4:1	5:1	1:1 - 5:1	1:1 - 5:1	1:1 - 5:1	1:1 - 5:1	1:1 - 5:1	1:1 - 5:1	
360	120	180	445	435	410	405	325	22	22	145	M20x37.5	325	205
450	160	225	570	530	530	520	410	22	22	185	M20x37.5	410	250

Frame Size	n1	n2	p	r1				r2	d1 key				d2 key
Ratio	1:1 - 5:1	1:1 - 5:1	1:1 - 5:1	1:1 - 2:1	3:1	4:1	5:1	1:1 - 5:1	1:1 - 2:1	3:1	4:1	5:1	1:1 - 5:1
360	3	3	140	M20	M20	M20	M16	M20	20x12x110	18x11x100	16x10x80	14x9x70	20x12x110
450	3	3	175	M24	M20	M20	M20	M24	25x14x140	20x12x110	20x12x110	18x11x100	25x14x140

Dimensions and Configurations

Solid Shaft Input, Hollow Shaft Output, Sizes 360-450

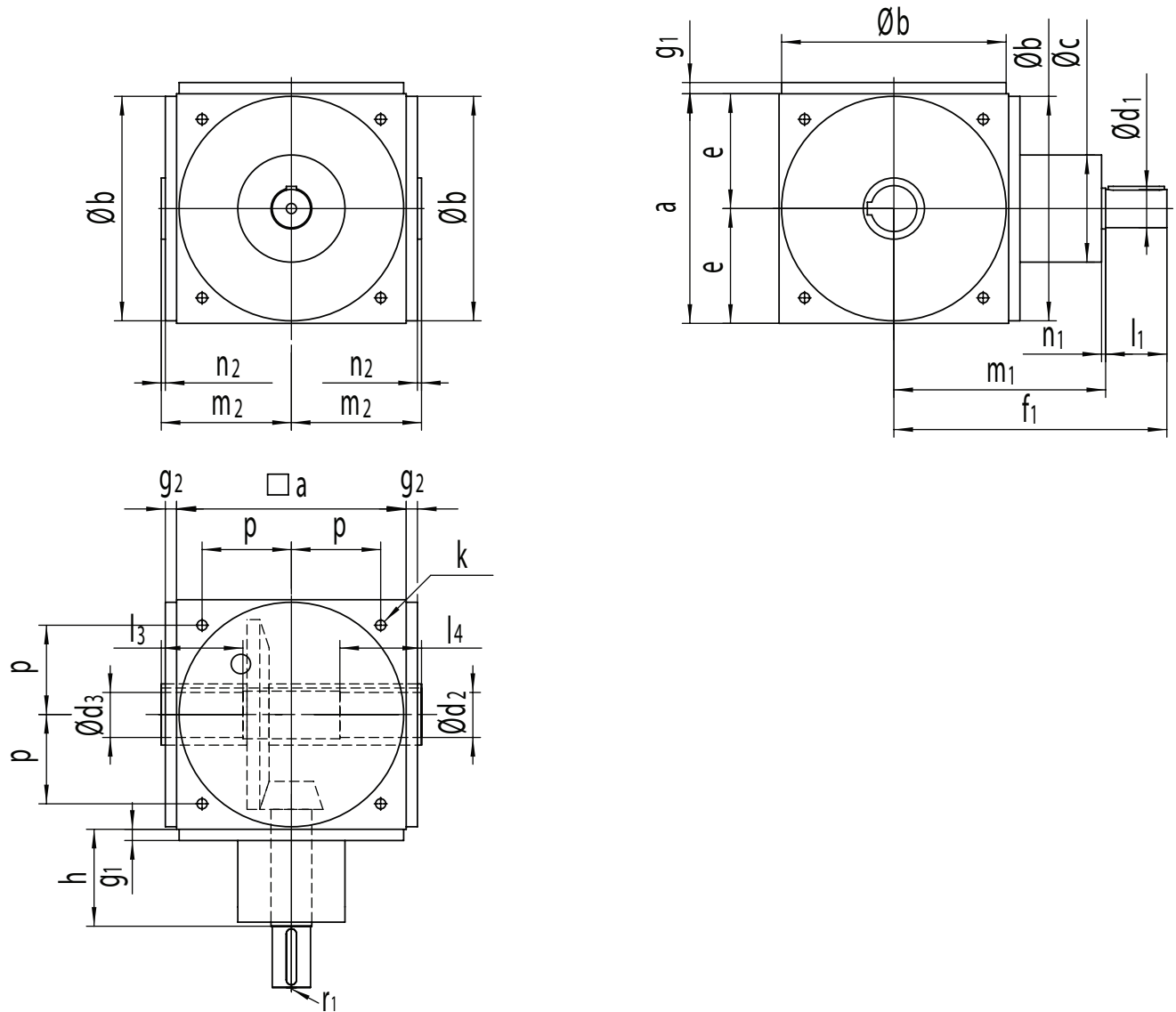

Frame Size	a	Øb h7	Øc		Ød1 k6				l1				Ød3 H7
Ratio	1:1 - 5:1	1:1 - 5:1	1:1 - 2:1	3:1 - 5:1	1:1 - 2:1	3:1	4:1	5:1	1:1 - 2:1	3:1	4:1	5:1	1:1 - 5:1
360	360	350	210	170	75	60	55	50	120	110	85	80	75
450	450	440	250	210	90	75	70	60	160	120	120	110	90

Frame Size	l3	l4	e	f1				g1	g2	h	k	m1	m2
Ratio	1:1 - 5:1	1:1 - 5:1	1:1 - 5:1	1:1 - 2:1	3:1	4:1	5:1	1:1 - 5:1	1:1 - 5:1	1:1 - 5:1	1:1 - 5:1	1:1 - 5:1	1:1 - 5:1
360	165	105	180	445	435	410	405	22	22	145	M20x37.5	325	205
450	200	140	225	570	530	530	520	22	22	185	M20x37.5	410	250

Frame Size	n1	n2	p	r1				d1 key				d3 key
Ratio	1:1 - 5:1	1:1 - 5:1	1:1 - 5:1	1:1 - 2:1	3:1	4:1	5:1	1:1 - 2:1	3:1	4:1	5:1	1:1 - 5:1
360	3	3	140	M20	M20	M20	M16	20x12x110	18x11x100	16x10x80	14x9x70	20x12
450	3	3	175	M24	M20	M20	M20	25x14x140	20x12x110	20x12x110	18x11x100	25x14

Dimensions and Configurations

High Torque Option: Solid Shaft Input, Solid Shaft Output, Sizes 54-280

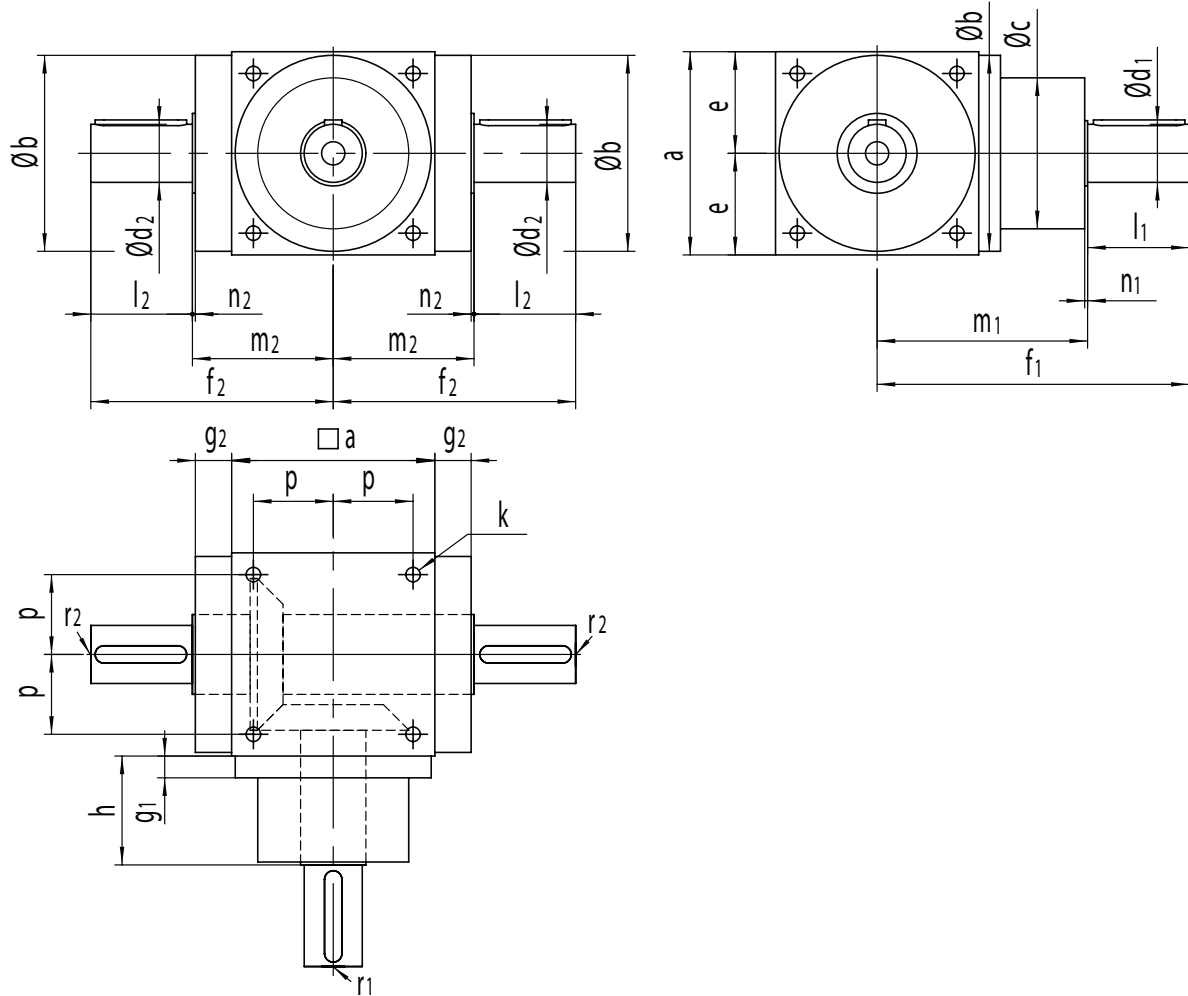

Frame Size	a	$\varnothing b$ h7	$\varnothing c$	$\varnothing d_1$ k6	l1	$\varnothing d_2$ k6	l2	e	f1	f2	g1	g2	h	k
54	54	53	53	14	30	14	30	27	102	69	43	11	45	M5x14.5
75	75	73	72	20	35	20	35	37.5	125	93	15	18.5	52.5	M6x12
90	90	88	86	25	40	25	40	45	140	105	15	18	55	M6x12
110	110	108	106	35	60	35	60	55	175	140	15	23	60	M8x15.5
140	140	135	104	40	70	40	70	70	215	167	15	25	75	M10x19.5
170	170	165	128	50	80	50	80	85	255	197	15	30	90	M12x23
210	210	205	160	60	110	60	110	105	320	252	20	35	105	M16x30
240	240	235	180	70	120	70	120	120	360	282	25	40	120	M16x30
280	280	275	200	80	150	80	150	140	425	338	25	46	135	M16x30

Frame Size	m1	m2	n1	n2	p	r1	r2	d1 key	d2 key
54	72	39	2	1	22	M5	M5	5x5x25	5x5x25
75	90	58	2	2	30	M6	M6	6x6x28	6x6x28
90	100	65	2	2	36	M10	M10	8x7x32	8x7x32
110	115	80	2	2	44	M12	M12	10x8x50	10x8x50
140	145	97	2	2	55	M16	M16	12x8x63	12x8x63
170	175	117	2	2	67	M16	M16	14x9x70	14x9x70
210	210	142	2	2	85	M20	M20	18x11x100	18x11x100
240	240	162	2	2	95	M20	M20	20x12x110	20x12x110
280	275	188	2	2	110	M20	M20	22x14x140	22x14x140

Dimensions and Configurations

High Torque Option: Solid Shaft Input, Hollow Shaft Output, Sizes 75-280

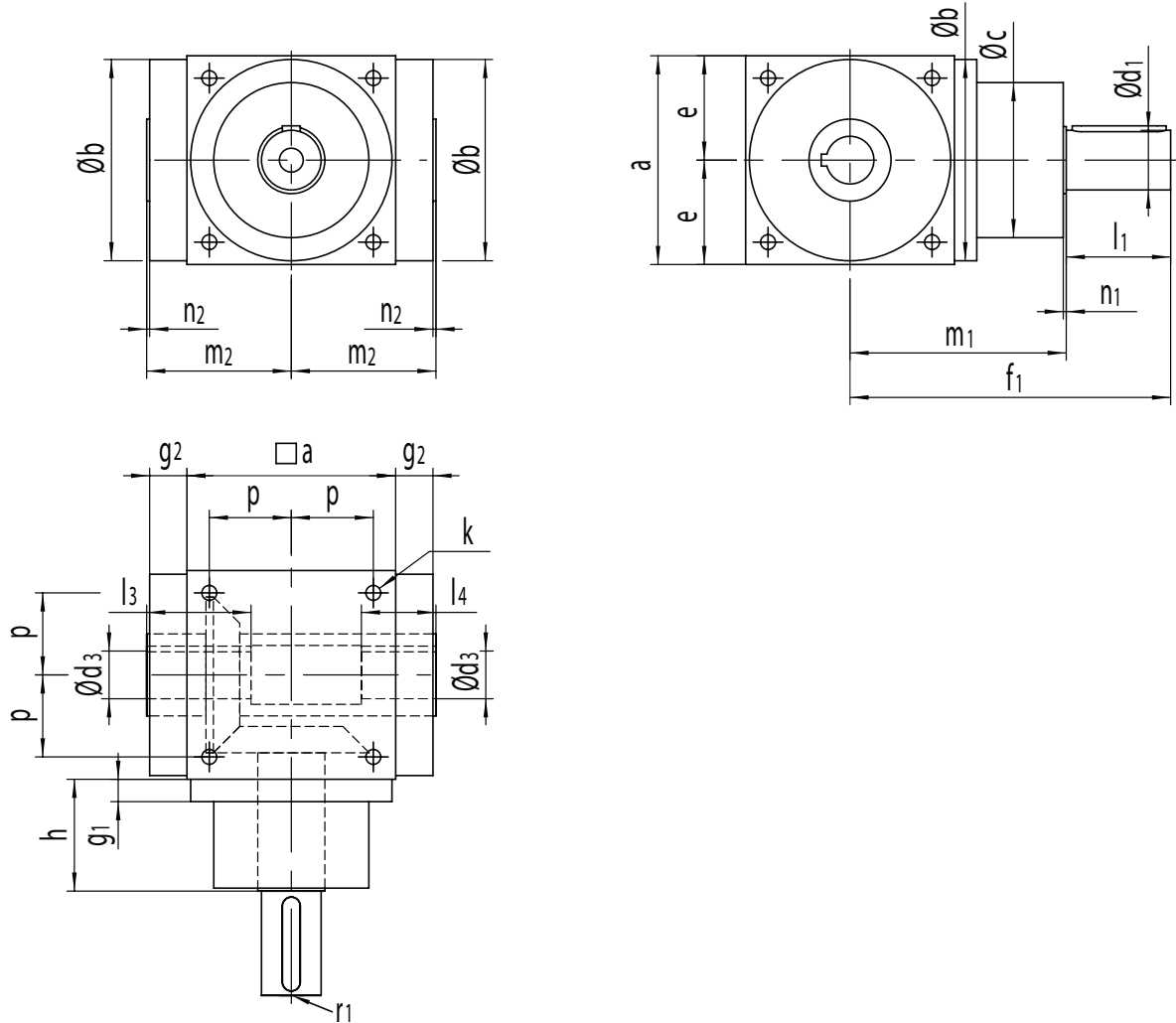

Frame Size	a	Øb h7	Øc	Ød1 k6	l1	Ød3 H7	l3	l4	e	f1	g1
75	75	73	72	20	35	14	47	32	37.5	125	15
90	90	88	86	25	40	18	50	35	45	140	15
110	110	108	106	35	60	22	60	45	55	175	15
140	140	135	104	40	70	32	70	50	70	215	15
170	170	165	128	50	80	40	95	70	85	255	15
210	210	205	160	60	110	50	95	70	105	320	20
240	240	235	180	70	120	55	115	80	120	360	25
280	280	275	200	80	150	60	130	90	140	425	25

Frame Size	g2	h	k	m1	m2	n1	n2	p	r1	d1 key	d3 keyway
75	18.5	52.5	M6x12	90	58	2	2	30	M6	6x6x28	5x5
90	18	55	M6x12	100	65	2	2	36	M10	8x7x32	6x6
110	23	60	M8x15.5	115	80	2	2	44	M12	10x8x50	6x6
140	25	75	M10x19.5	145	97	2	2	55	M16	12x8x63	10x8
170	30	90	M12x23	175	117	2	2	67	M16	14x9x70	12x8
210	35	105	M16x30	210	142	2	2	85	M20	18x11x100	14x9
240	40	120	M16x30	240	162	2	2	95	M20	20x12x110	16x10
280	46	135	M16x30	275	188	2	2	110	M20	22x14x140	18x11

Dimensions and Configurations

High Speed Option: Solid Shaft Input, Solid Shaft Output, Sizes 75-170

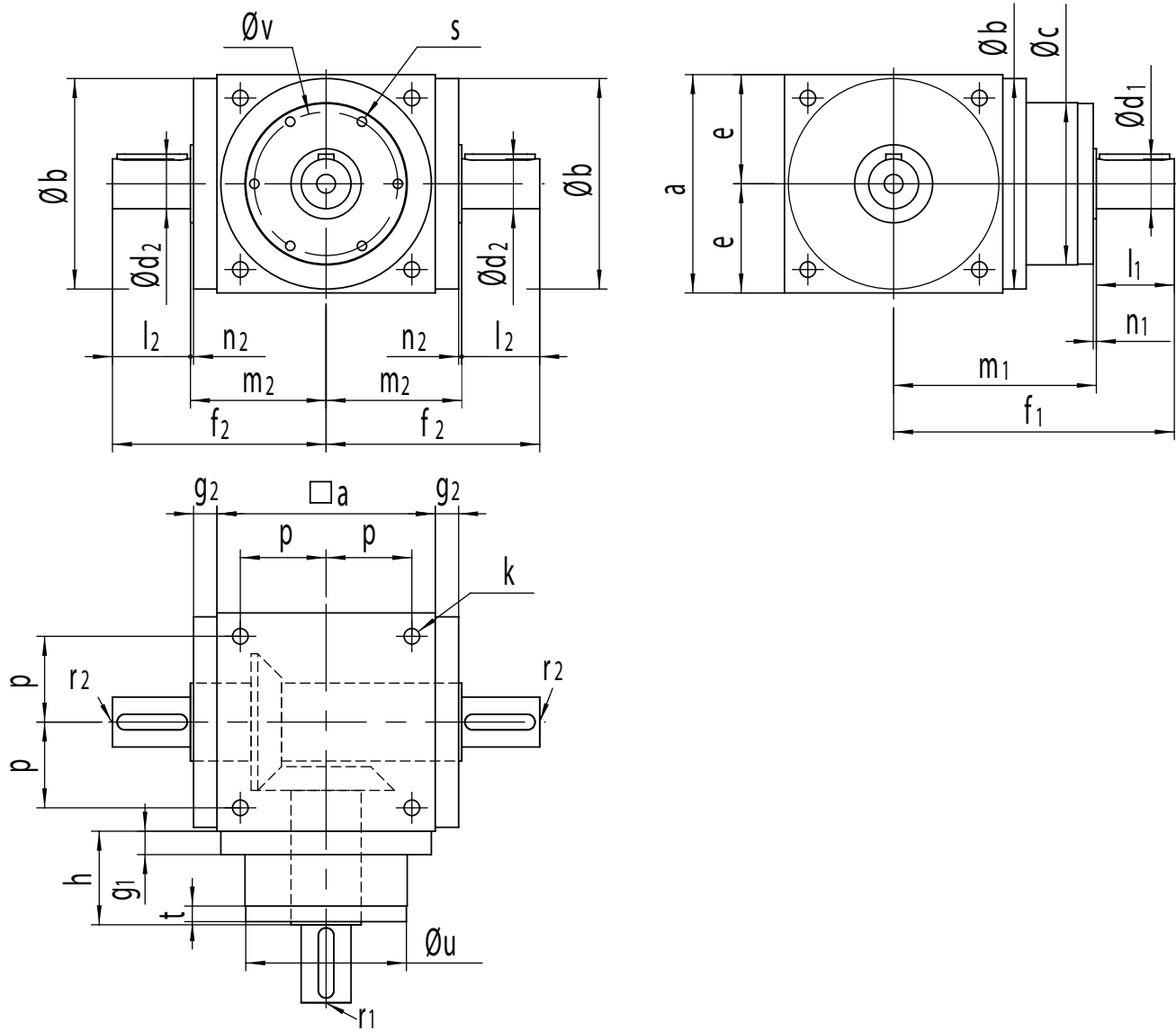

Frame Size	a	$\varnothing b$ h7	$\varnothing c$	$\varnothing d_1$ k6	l1	$\varnothing d_2$ k6	l2	e	f1	f2	g1	g2	h	k
75	75	73	72	12	26	12	26	37.5	116	75.5	15	10	52.5	M6x12
90	90	88	86	16	30	16	30	45	130	87	15	10	55	M6x12
110	110	108	106	18	35	18	35	55	150	102	15	10	60	M8x15.5
140	140	135	104	22	40	22	40	70	170	122	15	10	60	M10x19.5
170	170	165	128	32	50	32	50	85	205	149	15	12	70	M12x23

Frame Size	m1	m2	n1	n2	p	r1	r2	s	t	$\varnothing u$ g6	$\varnothing v$	d1 key	d2 key
75	90	49.5	2	2	30	M4	M4	4xM5x9	8	72.9	62	4x4x20	4x4x20
90	100	57	2	2	36	M5	M5	4xM5x12	8	87	76	5x5x25	5x5x25
110	115	67	2	2	44	M6	M6	6xM6x12	8	107	92	6x6x28	6x6x28
140	130	82	2	2	55	M8	M8	6xM6x12	10	107	92	6x6x32	6x6x32
170	155	99	2	2	67	M12	M12	6xM8x16	10	127	114	10x8x45	10x8x45

Dimensions and Configurations

High Speed Option: Solid Shaft Input, Hollow Shaft Output, Sizes 75-170

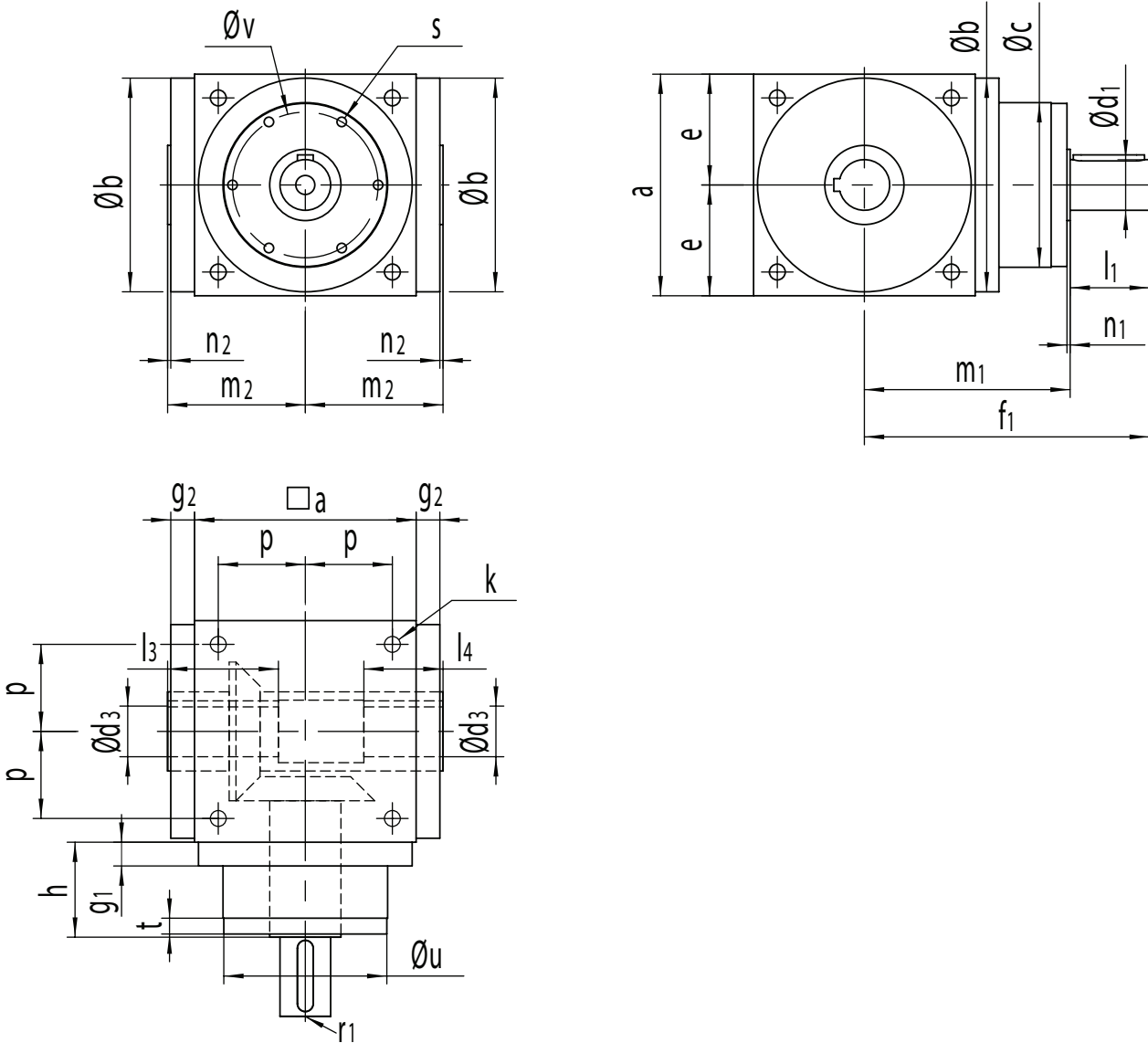

Frame Size	a	Øb h7	Øc	Ød1 k6	l1	Ød3 H7	l3	l4	e	f1	g1	g2	h
75	75	73	72	12	26	12	42	30	37.5	116	15	10	52.5
90	90	88	86	16	30	14	49	30	45	130	15	10	55
110	110	108	106	18	35	18	61	35	55	150	15	10	60
140	140	135	104	22	40	22	70	35	70	170	15	10	60
170	170	165	128	32	50	32	85	50	85	205	15	12	70

Frame Size	k	m1	m2	n1	n2	p	r1*	s	t	Øu g6	Øv	d1 key	d2 key
75	M6x12	90	49.5	2	2	30	M4	4xM5x9	8	72.9	62	4x4x20	4x4
90	M6x12	100	57	2	2	36	M5	4xM5x12	8	87	76	5x5x25	5x5
110	M8x15.5	115	67	2	2	44	M6	6xM6x12	8	107	92	6x6x28	6x6
140	M10x19.5	130	82	2	2	55	M8	6xM6x12	10	107	92	6x6x32	6x6
170	M12x23	155	99	2	2	67	M12	6xM8x16	10	127	114	10x8x45	10x8

Dimensions and Configurations

High Speed Option: Motor Adapter and Coupling Input, Solid Shaft Output, Sizes 75-170

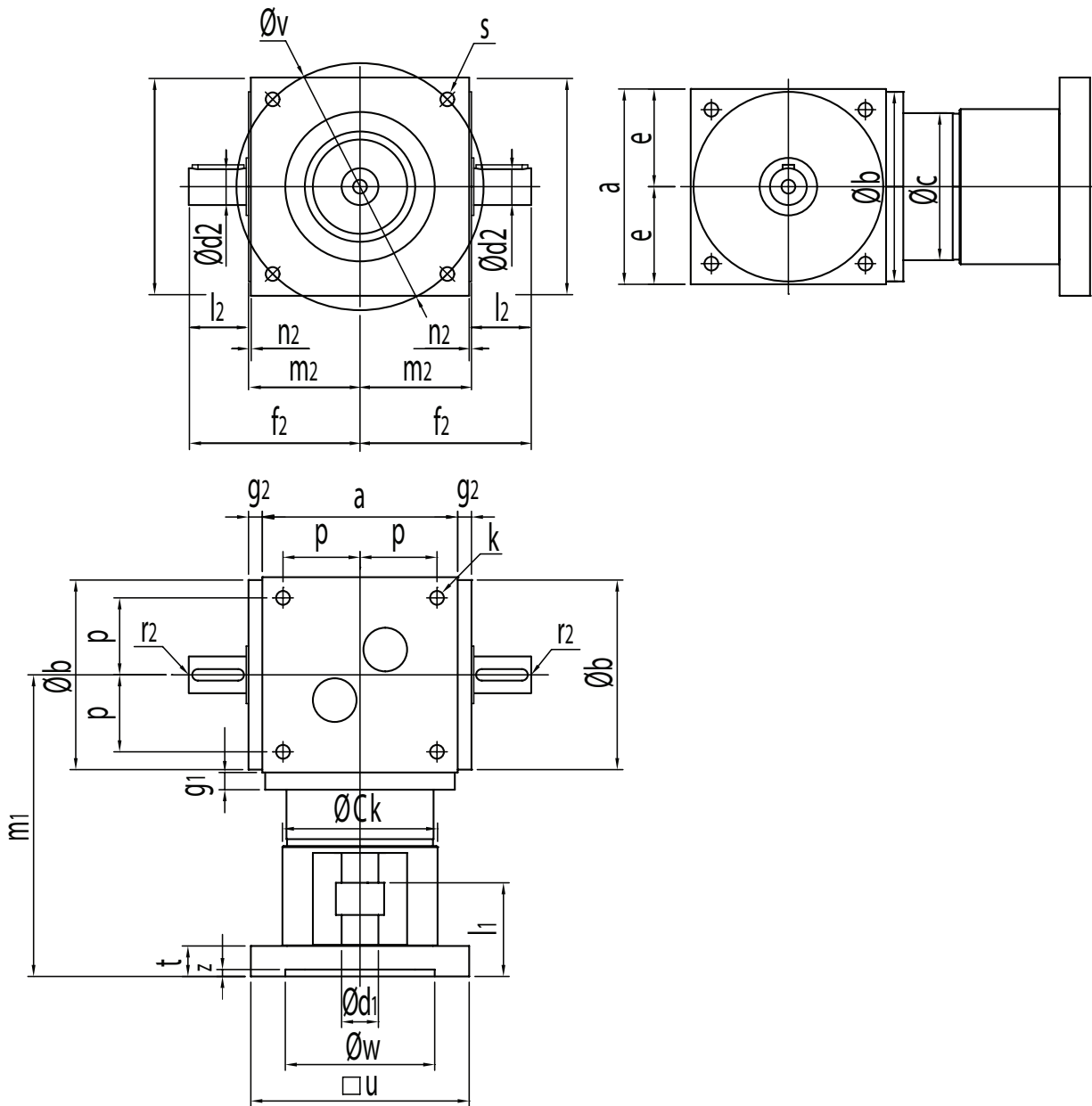

Frame Size	a	Øb h7	Øc	Ød2 k6	l2	e	f2	g1
75	75	73	72	12	26	37.5	75.5	15
90	90	88	86	16	30	45	87	15
110	110	108	106	18	35	55	102	15
140	140	135	104	22	40	70	122	15
170	170	165	128	32	50	85	149	15

Frame Size	g2	k	m2	n2	p	r2	s	d2 key
75	10	M6x12	49.5	2	30	M4	4xM5x9	4x4x20
90	10	M6x12	57	2	36	M5	4xM5x12	5x5x25
110	10	M8x15.5	67	2	44	M6	6xM6x12	6x6x28
140	10	M10x19.5	82	2	55	M8	6xM6x12	6x6x32
170	12	M12x23	99	2	67	M12	6xM8x16	10x8x45

Dimensions and Configurations

Motor Adapter Flange and Coupling Dimensions

Frame Size	Ød1	l1	□u	Øv	ØwF7	s	m1	t	z	Øck
75	9	20	75	63	40	M4	146.5	25	5	77
	11	23	75	75	60	M5	146.5	25	5	77
	14	30	90	100	80	M6	146.5	25	5	77
90	11	26	90	75	60	M5	166.5	25	5	92
	14	30	90	75	60	M5	166.5	25	5	92
	14	30	90	95	70	M6	166.5	25	5	92
	14	30	90	100	80	M6	166.5	25	5	92
	19	40	90	95	70	M6	166.5	25	5	92
	19	40	90	100	80	M6	166.5	25	5	92
	19	40	115	130	95	M8	166.5	25	5	92
	19	40	115	115	95	M8	166.5	25	5	92
	24	50	115	130	110	M8	173	31.5	5	92
110	14	30	110	95	80	M6	184.5	26	5	112
	14	30	110	100	80	M6	184.5	26	5	112
	19	40	110	100	80	M6	184.5	26	5	112
	19	40	115	115	95	M8	188	29.5	5	112
	19	40	115	130	95	M8	188	29.5	5	112
	19	40	115	130	110	M8	190	31.5	5	112
	24	50	115	130	110	M8	190	31.5	5	112
	24	50	140	165	110	M10	190	31.5	5	112
	24	50	140	165	130	M10	205	21.5	5	112
	32	60	140	165	130	M10	205	21.5	5	112
140	19	40	115	115	95	M8	203	29.5	5	112
	19	40	115	130	95	M8	203	29.5	5	112
	24	50	115	130	110	M8	205	31.5	5	112
	24	50	140	165	110	M10	205	31.5	5	112
	24	50	140	165	130	M10	220	21.5	5	112
	32	60	140	165	130	M10	220	21.5	5	112
	32	60	190	215	130	M12	221	22.5	6	112
	32	80	190	215	180	M12	235	36.5	6	112
	38	80	190	215	180	M12	235	36.5	6	112
170	24	50	140	165	110	M10	241	28.5	5	135
	24	50	140	165	130	M10	244	31.5	5	135
	32	60	140	165	130	M10	244	31.5	5	135
	32	60	190	215	130	M12	262.5	26.5	6	135
	32	60	190	215	180	M12	264	28	6	135
	38	80	190	215	180	M12	264	28	6	135

* Above Motor Adapter Flange and Coupling Dimensions are for common reference only and depend on motor dimensions. Contact us to configure adaptation for your specific motor.

Dimensions and Configurations

High Speed Option: Motor Adapter and Coupling Input, Hollow Shaft Output, Sizes 75-170

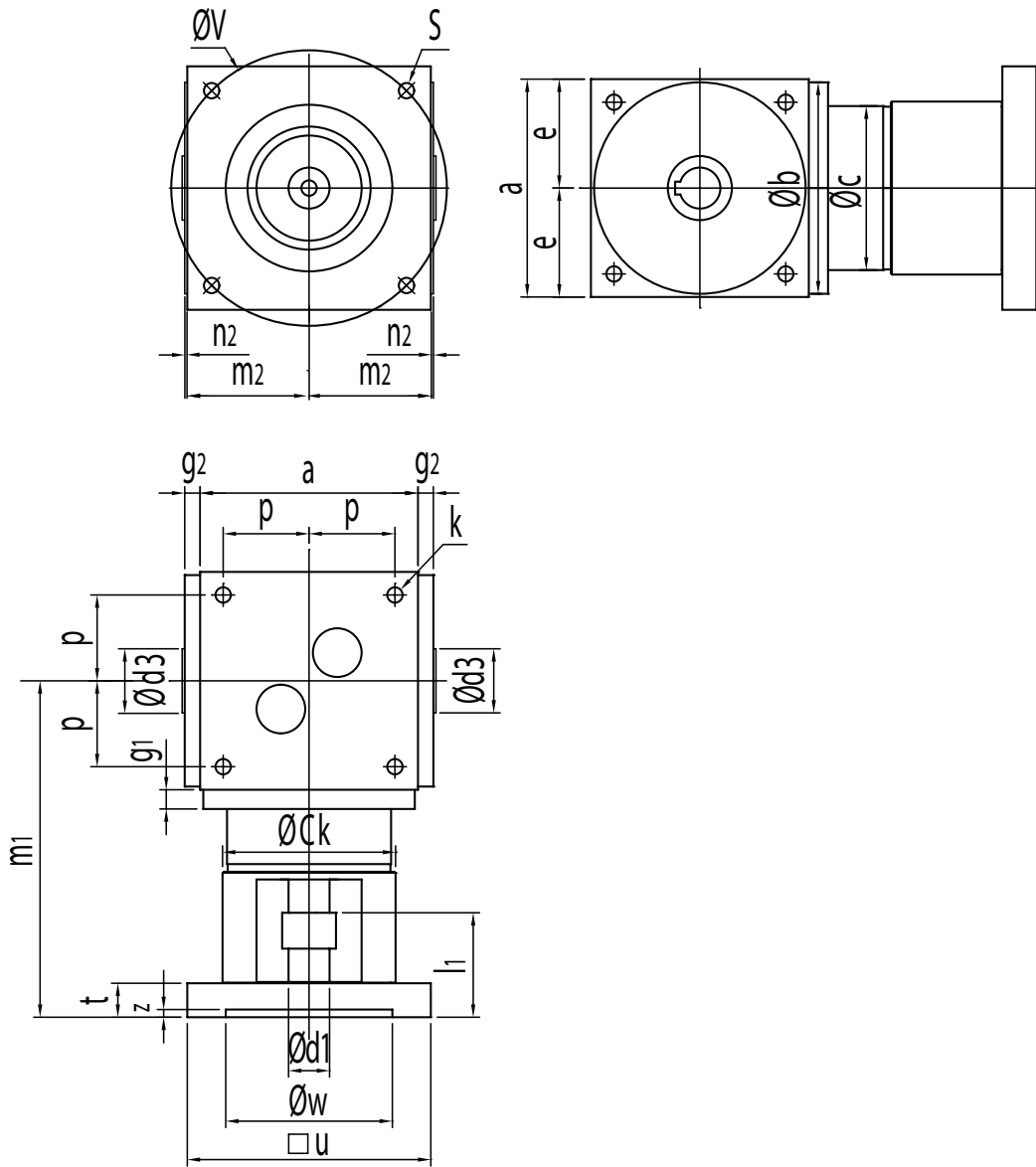

Frame Size	a	Øb h7	Øc	Ød3 H7	e	g1	g2
75	75	73	72	12	37.5	15	10
90	90	88	86	14	45	15	10
110	110	108	106	18	55	15	10
140	140	135	104	22	70	15	10
170	170	165	128	32	85	15	12

Frame Size	k	m2	n2	p	s	d3 key
75	M6x12	49.5	2	30	4xM5x9	4x4
90	M6x12	57	2	36	4xM5x12	5x5
110	M8x15.5	67	2	44	6xM6x12	6x6
140	M10x19.5	82	2	55	6xM6x12	6x6
170	M12x23	99	2	67	6xM8x16	10x8

Dimensions and Configurations

Motor Adapter Flange and Coupling Dimensions

Frame Size	Ød1	l1	□u	Øv	ØwF7	s	m1	t	z	Øck
75	9	20	75	63	40	M4	146.5	25	5	77
	11	23	75	75	60	M5	146.5	25	5	77
	14	30	90	100	80	M6	146.5	25	5	77
90	11	26	90	75	60	M5	166.5	25	5	92
	14	30	90	75	60	M5	166.5	25	5	92
	14	30	90	95	70	M6	166.5	25	5	92
	14	30	90	100	80	M6	166.5	25	5	92
	19	40	90	95	70	M6	166.5	25	5	92
	19	40	90	100	80	M6	166.5	25	5	92
	19	40	115	130	95	M8	166.5	25	5	92
	19	40	115	115	95	M8	166.5	25	5	92
	24	50	115	130	110	M8	173	31.5	5	92
	110	14	30	110	95	80	M6	184.5	26	5
14		30	110	100	80	M6	184.5	26	5	112
19		40	110	100	80	M6	184.5	26	5	112
19		40	115	115	95	M8	188	29.5	5	112
19		40	115	130	95	M8	188	29.5	5	112
19		40	115	130	110	M8	190	31.5	5	112
24		50	115	130	110	M8	190	31.5	5	112
24		50	140	165	110	M10	190	31.5	5	112
24		50	140	165	130	M10	205	21.5	5	112
32		60	140	165	130	M10	205	21.5	5	112
140	19	40	115	115	95	M8	203	29.5	5	112
	19	40	115	130	95	M8	203	29.5	5	112
	24	50	115	130	110	M8	205	31.5	5	112
	24	50	140	165	110	M10	205	31.5	5	112
	24	50	140	165	130	M10	220	21.5	5	112
	32	60	140	165	130	M10	220	21.5	5	112
	32	60	190	215	130	M12	221	22.5	6	112
	32	80	190	215	180	M12	235	36.5	6	112
170	38	80	190	215	180	M12	235	36.5	6	112
	24	50	140	165	110	M10	241	28.5	5	135
	24	50	140	165	130	M10	244	31.5	5	135
	32	60	140	165	130	M10	244	31.5	5	135
	32	60	190	215	130	M12	262.5	26.5	6	135
	32	60	190	215	180	M12	264	28	6	135

* Above Motor Adapter Flange and Coupling Dimensions are for common reference only and depend on motor dimensions. Contact us to configure adaptation for your specific motor.

Options and Modifications

Base Mounted Feet

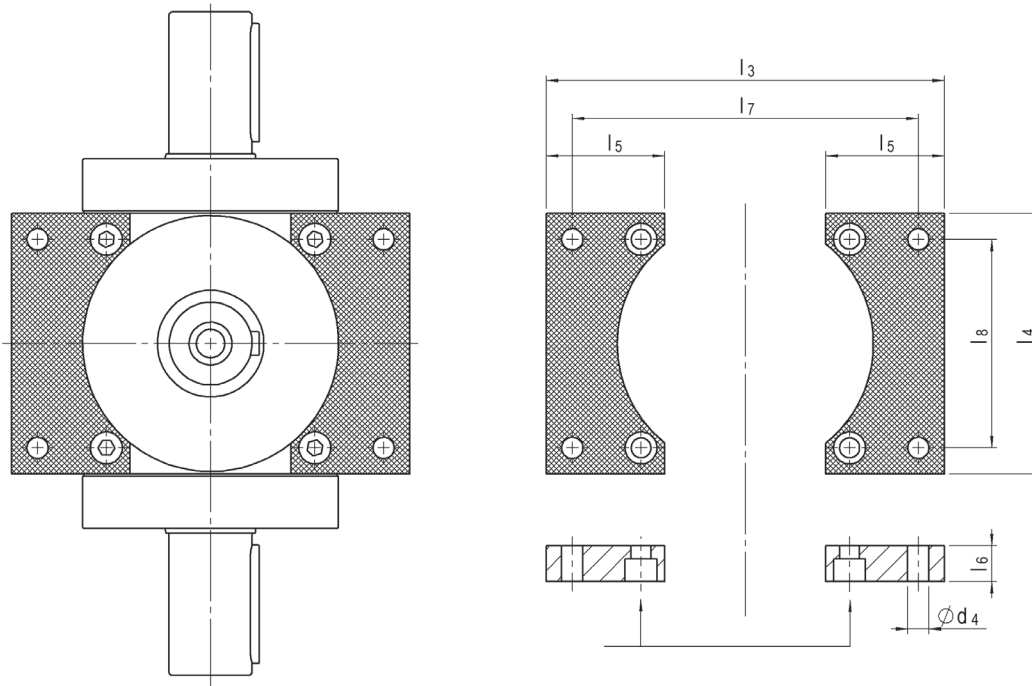

Frame Size	l3	l4 (-0.5)	l5	l6	l7 (+- 0.2)	l8 (+- 0.2)	Ød4	Screw Size	Total Weight (kg)
75	122	75	40	17	108	60	6.6	M6x12	0.6
90	145	90	45	17	125	72	6.6	M6x12	0.8
110	168	110	50	17	146	88	9	M8x18	1.1
140	208	140	60	20	178	110	11	M10x25	1.9
170	250	170	70	20	215	134	14	M12x25	2.7
210	310	210	90	25	265	170	18	M16x35	5.2
240	345	240	100	30	295	190	18	M16x35	8
280	385	280	100	30	335	220	18	M16x35	9.6
360	480	360	125	30	430	280	22	M20x40	15
450	580	450	140	30	520	350	22	M20x40	21.2

* Four socket head screws are included

Shaft Geometry

1. Shortened shaft.
2. Smooth shaft.
3. Shrink disc shaft.

Environmental

1. USDA Food Grade Oil.
2. Stainless steel housing, output shaft & fasteners.
3. Viton or Teflon seals.
4. ATEX compliance.

Cooling

1. Oil circulation system: Gearbox is supplied ready for connection to external oil supply. External oil supply may consist of an oil tank, air-oil cooler, oil pump and pipework between oil tank and gearbox.
2. Forced oil circulation system: For higher speeds, it may be necessary to use forced lubrication to ensure maximum life for the gear teeth and bearings. Gearbox is connected to an external pressurized lubrication system.
3. Aluminum cooling fins: Increased heat dissipation.
4. Aluminum cooling fins with fan: Further increased heat dissipation via mounted radial fan.
5. Water cooling: Gearbox is supplied ready for connection to an external water cooler. The oil reservoir is cooled by a cooling coil.

Installation Information

Side Definition

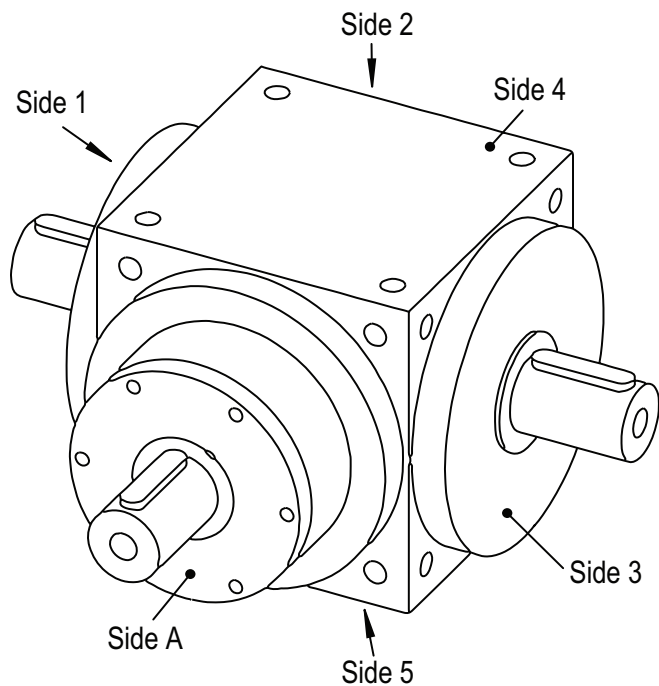

Shaft Arrangements and Driving Configurations

Solid Output

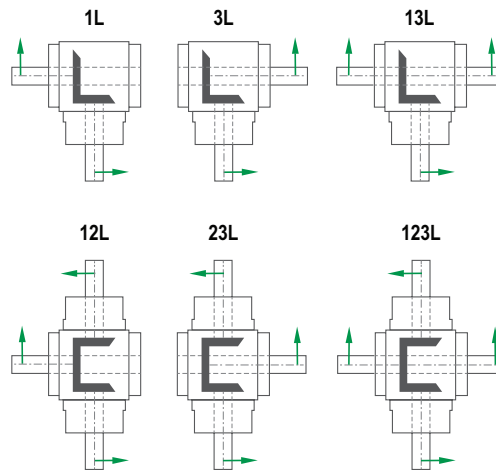

Hollow Output

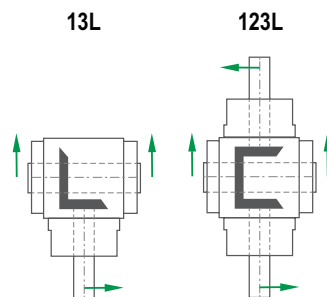

Hollow Output with Shrink Disc Shaft

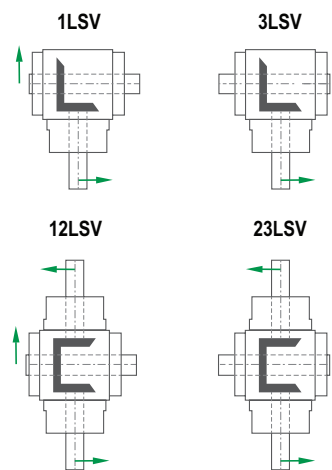

Mounting Positions

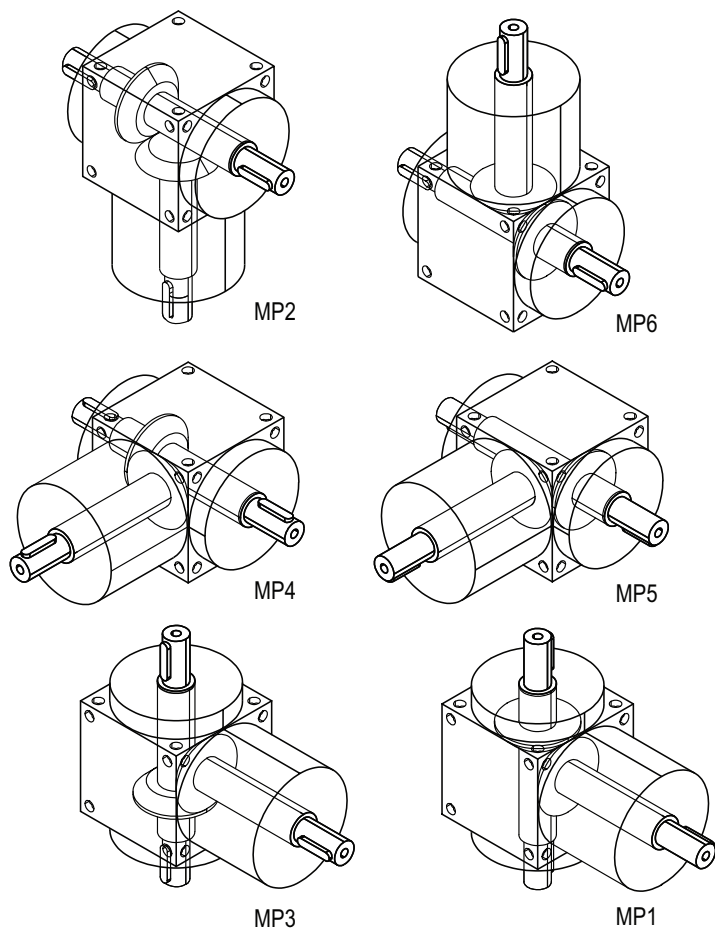

Gearbox Selection and Maintenance

Gearbox Selection Procedure

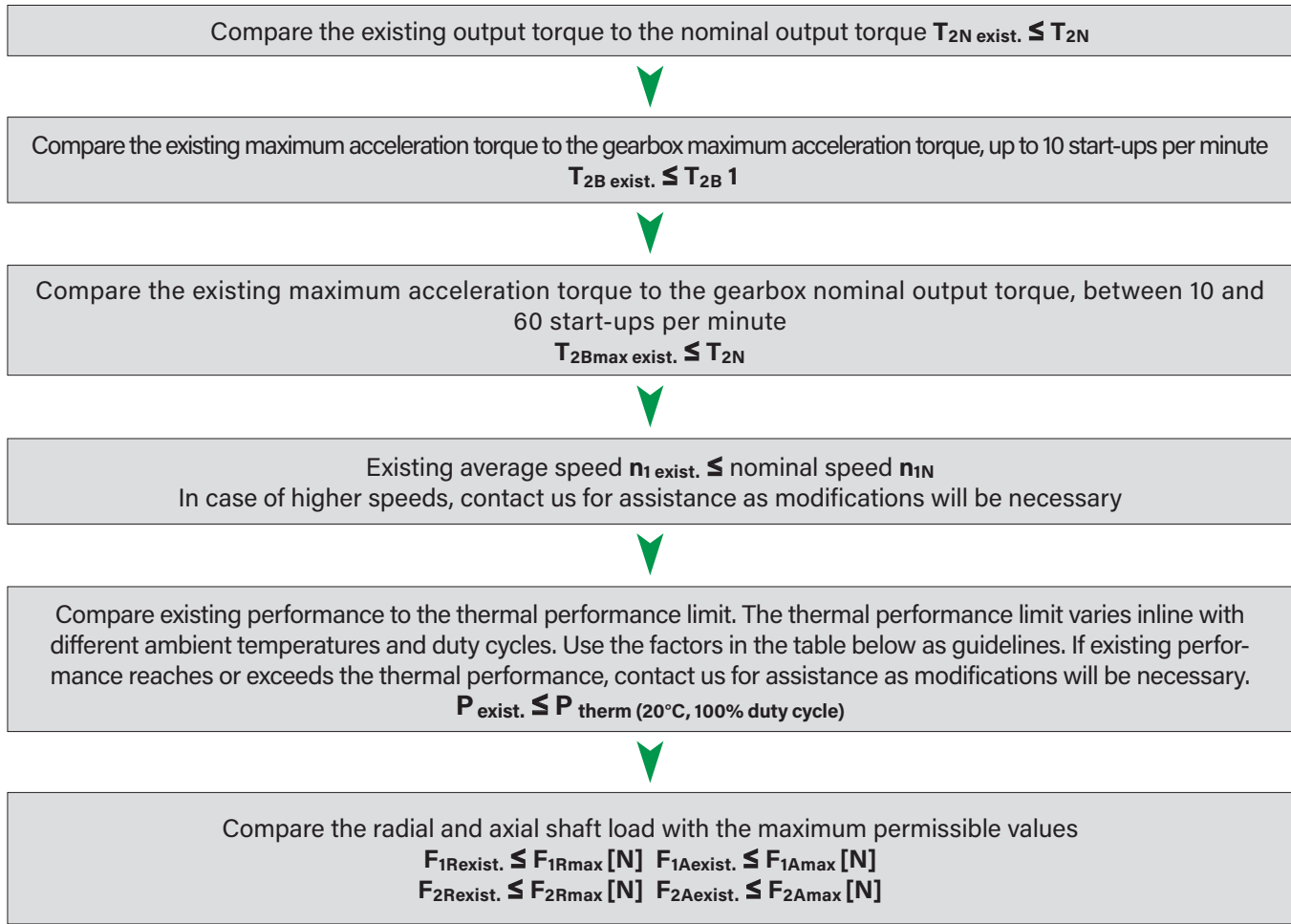

*Above selection is based on S5 cyclical duty cycle [DC] of <60% and run time [RT] < 20 min. Contact us for sizing assistance for S1 continuous operation.

Thermal Performance Limits

Duty Cycle [%]	100	80	60	40	20
Factor	1.0	1.2	1.4	1.6	1.8

Ambient Temperature [°C]	10	20	30	40	50
Factor	1.2	1.0	0.87	0.75	0.62

Frame Size	54	65	75	90	110	140	170	210	240	280	360	450
Thermal Performance Limit P_{therm}	1.6	2.5	2.9	4.1	5.7	9.2	13.2	21.2	28.4	38.4	60.0	93.4

* Based on 20°C, 100% duty cycle.

* Gearbox performance is limited by max permissible oil bath temperature. The actual performance must not exceed the permissible limit when in continuous operation.

* For intermittent operation or in the event of increased ambient temperature, the factors above can be applied as guidelines for determining the permissible thermal performance limit.

Gearbox Selection and Maintenance

Gearbox Maintenance and Lubrication

Nidec Drive Technology Corporation PowerGear spiral bevel gearboxes are supplied lubricated unless requested otherwise. Frame sizes 27-45 are supplied with synthetic grease and are maintenance free. Sizes 54-110 are oil filled, but do not include oil drain holes and are therefore also maintenance free. Oil changes can be performed on frame sizes 140-450.

For operating temperatures up to 80°C, we recommend the use of mineral hypoid gear oil API GL-4 to MIL-L-2105-A specification. For operating temperatures up to 95°C, we recommend the use of synthetic gear oils based on Poly-Alpha-Olefins (PAO) and for temperatures of up to 120°C, polyglycol-based synthetic gear oils to ISO VG-Class 150 (DIN 51519) or CLP DIN 51517 specification. In case of high temperatures, special seals must be specified.

The first oil change must be carried out after 500 operating hours. Draining the oil should take place immediately after the unit has been shut down, while the oil is still warm. Further oil changes are recommended every 5,000 operating hours and time intervals should not exceed 18 months. Oil drain plugs are fitted on all sides of the gearbox except the input side. Before re-filling, please ensure that all drain plugs have been inserted and tightened with the exception of the oil filling screw. In cases of doubt, please use new oil seals. When changing oil, we recommend that you fill the gear unit with the type of oil previously used. In particular, synthetic oils must not be mixed with mineral oils or other oil variants. When changing from mineral oil to synthetic oil, the gearbox must be rinsed thoroughly with the new oil type.

Upon request, gearboxes can be supplied with a lubricant indicator (oil sight glass, angular oil level indicator, oil dipstick). This requires details about mounting position and speed. Gearboxes without a lubricant indicator can be filled with the recommended average quantity of oil when speeds are low and the gearbox is installed pointing upwards. If the gearbox has a lubricant indicator, filling can be carried out precisely. The middle of the oil sight glass indicates the minimum fill level, whereas the maximum fill level is reached when an air bubble above the oil is still visible in the sight glass.

The condition of the gearbox, especially the leak tightness and the oil level must be checked regularly. Shaft seals which leak must be replaced to ensure operational safety. Please contact us for more detailed disassembly and lubrication instructions as well as lubricant options. Service kits with wear parts are available from our service department. Our products can also be sent back to the factory for inspection and lubrication.

Oil Quantities

Frame Size	54	65	75	90	110	140	170	210	240	280	360	450
Average Oil Quantity (liters)	0.05	0.07	0.1	0.2	0.3	0.4	1.0	2.2	2.6	3.0	9.0	22.0
Maximum Oil Capacity (liters)	-	-	-	-	0.35	0.6	1.2	2.5	3.5	5.0	15.0	32.0

* Oil quantity is dependent on ratio, speed, shaft arrangement and installation position.

www.nidec-dtc.com

Nidec

NIDEC DRIVE TECHNOLOGY CORPORATION
175 Wall Street, Glendale Heights, IL 60139 USA
Phone: (800) 842-1479 • info@nidec-dtc.com